



Axial Piston Variable Motor HA6VM Series 63/69

Series: 63

Size: 28/55/80/107/160/200 mL/r 250 mL/r

Rated pressure: 40 MPa

Max. pressure: 45 MPa

Series: 69

Size: 115/130/170/215 mL/r

Rated pressure: 40 MPa

Max. pressure: 45 MPa



Features



- Axial piston motor of bent-axis design for hydrostatic drives in open and closed circuits
- Axial tapered piston rotary group
- The output torque increases with the pressure differential between the high- and low-pressure sides and with increasing displacement
- The wide control range allows the variable motor to satisfy the requirements for high speed and high torque
- The displacement can be continuously changed from $V_{g \max}$ to $V_{g \min}=0$
- High cost performance through elimination of gearboxes
- Compact, robust bearing system with long service life
- High power density
- Small moment of inertia and wide motion range of bent axis
- Various control options to realize diverse control and regulation functions

Contents



- Model Code.....02
- Structure.....06
- Technical Data.....09
- HD Proportional Hydraulic Control 11
- HZ Two-point Hydraulic Control.....13
- EP Electric Control with Proportional Solenoid..... 14
- EZ Electric Control with Switching Solenoid..... 16
- HA High-pressure Related Automatic Control.....18
- Installation Dimensions,55.....21
- Installation Dimensions,80.....24
- Installation Dimensions,107/115/130.....27
- Installation Dimensions,160/170.....30
- Installation Dimensions,200.....36
- Flushing and Boost-pressure Valve.....37
- Counterbalance Valve BVD and BVE.....40
- Installation Instructions.....42



> Model Code

	c	A	B	E	H	I	K	L	M	N	P	R	V	X	Y	Z
HA6V	M				/	W		-			B				-	

Axial piston unit

—	Bent-axis design, variable displacement piston motor	HA6V
---	--	------

Operating mode

C		28	55	80	107	115	130	160	170	200	215	250	
	Motor(flange)	○	●	●	●	●	●	●	●	●	○	○	M

Displacement

A	Geometric displacement, in mL/r	28	55	80	107	115	130	160	170	200	215	250	
---	---------------------------------	----	----	----	-----	-----	-----	-----	-----	-----	-----	-----	--

Control device

B	Proportional Hydraulic control	Δp=1.0MPa	○	●	●	●	●	●	●	●	○	○	HD1	
		Δp=2.5MPa	○	●	●	●	●	●	●	●	○	○	HD2	
		Δp=3.0MPa	—	—	—	—	—	—	—	—	—	○	HD3	
	Two-point hydraulic control		—	—	—	—	—	—	—	—	—	○	HZ	
			○	—	—	●	●	●	●	●	●	○	—	HZ1
			—	●	●	○	○	○	—	—	—	—	—	HZ3
	Electric control with proportional solenoid	U=12V	○	●	●	●	●	●	●	●	●	○	○	EP1
		U=24V	○	●	●	●	●	●	●	●	●	○	○	EP2
	Electric control with switching solenoid	U=12V	○	—	—	●	●	●	●	●	●	○	○	EZ1
		U=24V	○	—	—	●	●	●	●	●	●	○	○	EZ2
		U=12V	—	●	●	○	○	○	—	—	—	—	—	EZ3
		U=24V	—	●	●	○	○	○	—	—	—	—	—	EZ4
	Automatic control High-pressure related	With minimum pressure increase, Δp=1MPa	○	●	●	●	●	●	●	●	●	○	○	HA1
		With pressure increase, Δp=10MPa	○	●	●	●	●	●	●	●	●	○	○	HA2

Pressure control (for HD/EP/EZ¹⁾/HZ¹⁾)

E		28	55	80	107	115	130	160	170	200	215	250		
	Without pressure control (without code)	○	●	●	●	●	●	●	●	●	○	○		
	Pressure control	Fixed control	○	●	●	●	●	●	●	●	●	○	○	D
		Two-point hydraulic override control	○	○	○	○	○	○	○	○	○	○	2)	E
Hydraulic remote proportional control		—	—	—	—	—	—	—	—	—	—	○	G	

1): No fixed setting of D for sizes 28 to 80; 2): Standard configuration with version D (Size 250) .



► Model Code

	c	A	B	E	H	I	K	L	M	N	P	R	V	X	Y	Z
HA6V	M					/	W		-		B					-

Override control (only for HA)

H		28	55	80	107	115	130	160	170	200	215	250	
	Without override control (without code)	○	●	●	●	●	●	●	●	●	○	○	
	Hydraulic override control/remote control/proportional control	○	●	●	●	●	●	●	●	●	○	○	T
	Two-point electronic override control		U=12V	○	○	○	○	○	○	○	○	○	—
		U=24V	○	○	○	○	○	○	○	○	○	—	U2

Series

I		28	55	80	107	115	130	160	170	200	215	250	
	7-piston	○	●	●	●	—	—	●	—	●	—	○	63
	9-piston	—	—	—	—	●	●	—	●	—	○	—	69

Direction of rotation (viewed on drive shaft)

K													
	Bi-directional												W

Setting range for displacement

L		28	55	80	107	115	130	160	170	200	215	250	
	V _{g min} =0 to 0.7 V _{g max} (without code)	○	●	●	●	●	●	●	●	●	○	—	
	V _{g min} =0 to 0.4 V _{g max} ;V _{g max} =V _{g max} to 0.8 V _{g max}	○	●	●	●	●	●	●	●	●	○	○	1
	V _{g min} >0.4 V _{g max} to 0.8 V _{g max} ;V _{g max} =V _{g max} to 0.8 V _{g max}	○	●	●	●	●	●	●	●	●	○	○	2

Sealing material

M		28	55	80	107	115	130	160	170	200	215	250	
	NBR seal + FKM Shaft seal	○	○	○	○	○	○	○	○	○	○	○	N
	NBR seal	○	●	●	●	●	●	●	●	●	○	○	P
	FKM seal	○	●	●	●	●	●	●	●	●	○	○	V

Drive shaft

N		28	55	80	107	115	130	160	170	200	215	250		
	Splined shaft DIN 5480	○	●	●	●	●	●	●	●	●	—	—	○	Z
		○	●	●	●	●	●	●	●	●	●	○	—	A
	Parallel keyed shaft DIN 6885	—	—	—	—	—	—	—	—	—	—	○	P	



Model Code

	c	A	B	E	H	I	K	L	M	N	P	R	V	X	Y	Z
HA6V	M					/	W		-		B					-

Mounting flange

P		28	55	80	107	115	130	160	170	200	215	250	
	4-hole, ISO 3019-2	○	●	●	●	●	●	●	●	●	○	○	B

Working port

R			28	55	80	107	115	130	160	170	200	215	250		
	Working ports A/B at rear sides, SAE flange ports, metric fastening thread	01	0	○	●	●	●	●	●	●	●	○	○	010	
			7	○	●	●	●	●	●	●	●	○	○	017	
	Working ports A/B at opposite sides, SAE flange ports, metric fastening thread	02	0	○	●	●	●	●	●	●	●	○	○	020	
			7	○	●	●	●	●	●	●	●	○	○	027	
	SAE flange ports, A/B on both sides, at opposite sides+ rear sides	15	0	—	—	—	—	—	—	—	—	—	○	150	
	Port plate with 1-stage pressure relief valve for mounting a counterbalance valve	BVD20	37	0	—	—	—	●	●	●	—	—	—	—	370
					—	—	—	●	●	●	—	—	—	—	—
		BVD20/BVD25	38	—	○	●	●	●	●	●	○	○	○	380	
				—	○	●	●	●	●	●	○	○	○	388	
BVE		38	8	—	—	—	●	●	●	●	○	—	—	380	
				—	—	—	●	●	●	●	○	—	—	388	



Without valve	0
With flushing valve and oil replenishment valve	7
With balance valve	8

Speed measurement

V		28	55	80	107	115	130	160	170	200	215	250	
	Without speed sensor(without code)	○	●	●	●	●	●	●	●	●	○	○	
	Prepared for use with speed sensor	○	●	●	●	●	●	●	●	●	○	○	F0
	With speed sensor(without connector)	○	●	●	●	●	●	●	●	●	○	○	F
	With speed sensor(DT04-4P connector)	○	●	●	●	●	●	●	●	●	○	○	F1
	With speed sensor(DTM04-4P connector)	○	●	●	●	●	●	●	●	●	○	○	F2
With speed sensor(DTM04-6P connector)	○	●	●	●	●	●	●	●	●	○	○	F3	

Connector for solenoids

X		28	55	80	107	115	130	160	170	200	215	250	
	Without Connector for solenoids(without code)	○	●	●	●	●	●	●	●	●	○	○	
	DEUTSCH molded connector, 2-pin, without suppressor diode	○	●	●	●	●	●	●	●	●	○	○	P



> Model Code

	c	A	B	E	H	I	K	L	M	N	P	R	V	X	Y	Z
HA6V	M				/		W		-		B				-	

Beginning of control

Y		28	55	80	107	115	130	160	170	200	215	250	
	At $V_{g\ min}$ (standard for HA)	○	●	●	●	●	●	●	●	●	○	○	A
	At $V_{g\ max}$ (standard for HD/EP/EZ)	○	●	●	●	●	●	●	●	●	●	○	○

Special configuration

Z		
	Without special configuration(without code)	
	Special configuration ³⁾	***

³⁾: Please contact us for specific special configuration details.

- Available
- On request
- Not available
- Recommended model



> Structure

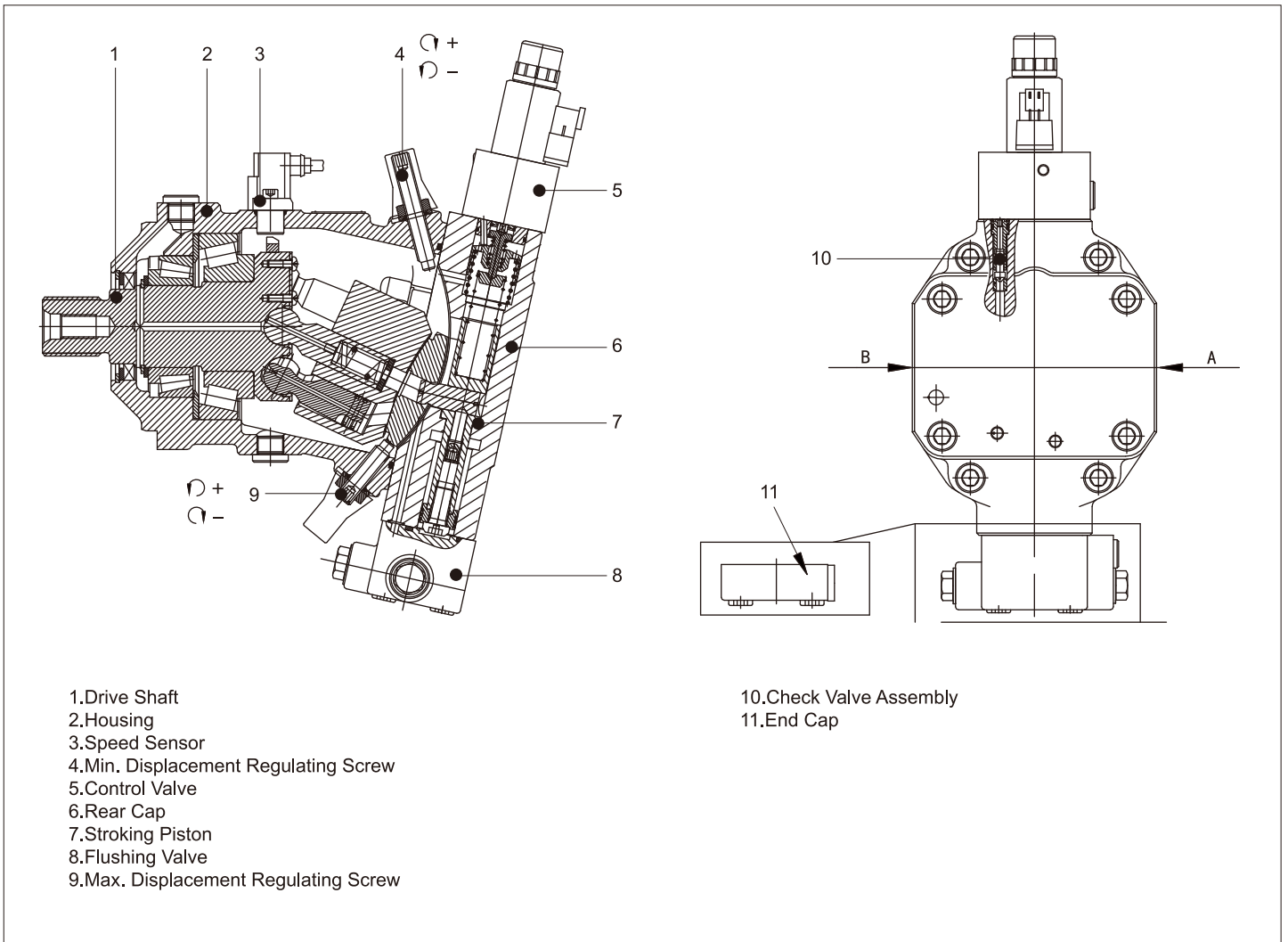



> Hydraulic Fluid

Mineral oil

> Working Viscosity

In order for the optimum efficiency and service life, it is recommended to select the working viscosity at working temperature within the range below:

$$V_{opt} = \text{optimal working viscosity } 16 \dots 36 \text{ mm}^2/\text{s}$$

It is subject to the circuit temperature of a closed circuit and the reservoir temperature of an open circuit.

> Limit Viscosity

Limit Viscosity:

$$V_{min} = 5 \text{ mm}^2/\text{s}$$

Short-term operation ($t < 3 \text{ min}$),

permissible maximum temperature $t_{max} = +115^\circ\text{C}$

$$V_{max} = 1600 \text{ mm}^2/\text{s}$$

Short-term operation ($t < 3 \text{ min}$),

Cold start ($p \leq 3 \text{ MPa}$, $n \leq 1000 \text{ rpm}$, $t_{min} = -40^\circ\text{C}$)

> Selection Diagram

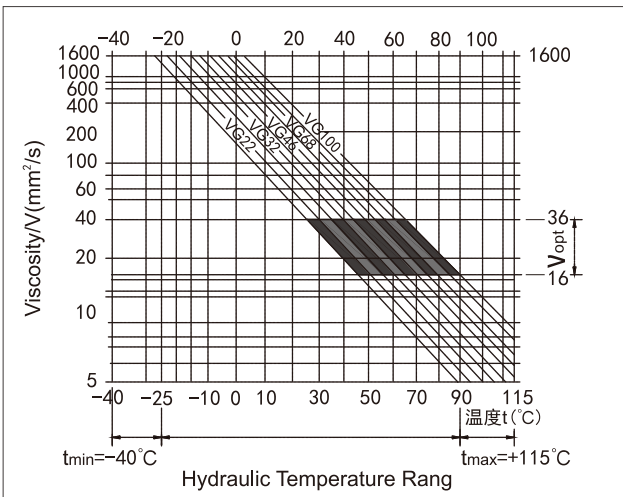

> Instructions on Selection of Hydraulic Fluid

The working temperature dependent on the ambient temperature is required for correct selection of hydraulic fluid. It refers to the circuit temperature of a closed circuit and the reservoir temperature of an open circuit.

The hydraulic fluid should be so selected that the working viscosity in the working range is within the optimum range (V_{opt} , the shaded area on the selection diagram). The higher viscosity is recommended in all applications.

For example: At an ambient temperature of $X^\circ\text{C}$, the working temperature of the circuit is 60°C . The viscosity within the optimum range (V_{opt} , shaded area) is VG46 or VG68 and the latter should be selected.

Note: The case drain temperature depends on the pressure and speed, and it is always higher than the circuit temperature. The temperature at any point within the system should not exceed $+115^\circ\text{C}$.

If the above condition cannot be maintained due to extreme working conditions, it is recommended to flush the housing via port U or through the flushing and boost-pressure valve.

> Filtration

Finer filtration improves the cleanliness level of the hydraulic fluid, thus increasing the service life of the axial piston unit. To ensure normal operation of the axial piston unit, a cleanliness level of at least 20/18/15 according to ISO 4406 is to be maintained.

When the hydraulic fluid has a high temperature (90°C to 103°C), the cleanliness level should at least reach 19/17/14 according to ISO 4406. Please contact us if the above cleanliness level cannot be reached.

> Working Pressure Range

63/69 series

Max. pressure at port A or B

Size 28-215

Rated pressure P_N _____ 40MPa

Maximum pressure P_{max} _____ 45MPa

Single working time _____ 10s

Total working time _____ 300h

Total pressure (pressure A + pressure B) P_{max} _____ 70MPa

Size 250

Rated pressure P_N _____ 35MPa

Maximum pressure P_{max} _____ 40MPa

Single working time _____ 10s

Total working time _____ 300h

Minimum pressure _____ 2.5MPa

Total pressure (pressure A + pressure B) P_{max} _____ 70MPa

Note:

Rated pressure P_N

Rated pressure refers to the maximum pressure designed.

Maximum pressure P_{max}

The maximum pressure at the inlet of the motor during a single operating time.

Minimum pressure (high pressure side)

To ensure the normal operation of the motor, the minimum pressure required on the high-pressure side.

Total pressure

Total pressure is defined as the combined pressure of working pipelines A and B.

> Flow Direction

Direction of rotation, viewed on drive shaft

CW	CCW
A to B	B to A

No limit to minimum speed n_{min} .

If uniformity of motion is required, n_{min} must not be less than 50rpm.



> Shaft Seal

Permissible Pressure Load

The service life of the shaft seal is influenced by the motor speed and the case drain pressure.

The average sustained case drain pressure at the recommended operating temperature must not exceed 0.3MPa absolute (with the maximum permissible case drain pressure being 0.6MPa at reduced speeds).

Short-term pressure peaks ($t < 0.1s$) may reach up to 1MPa absolute.

The more frequently pressure peaks occur, the shorter the shaft seal service life becomes.

The pressure within the casing must maintain equal or higher values than the external pressure acting on the shaft seal.

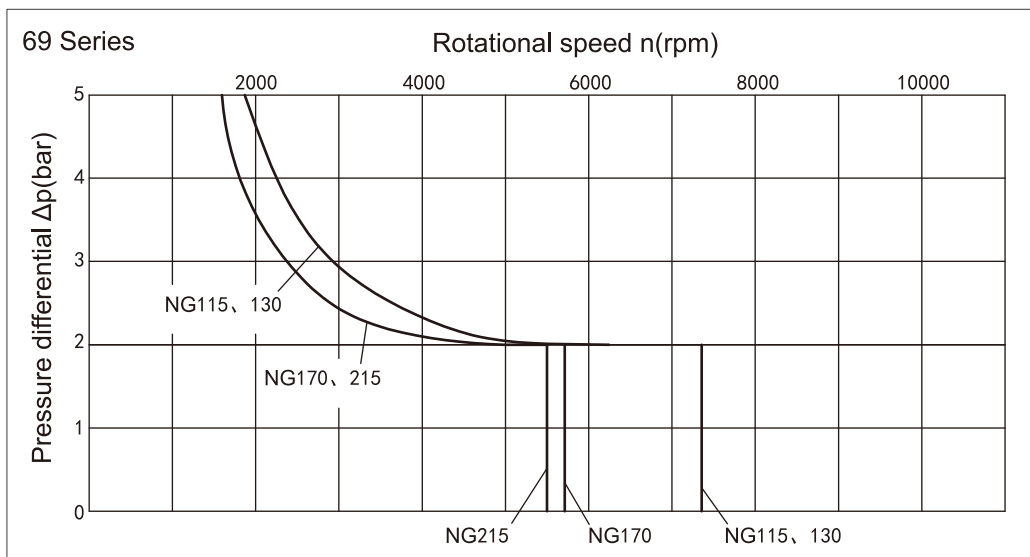
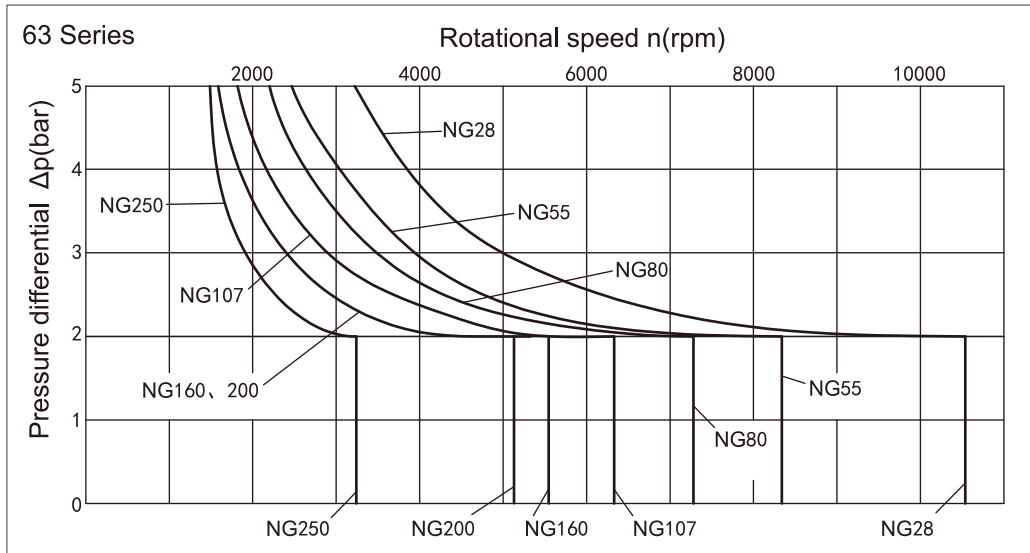

> Operating temp range

FKM Shaft Sealing Rings are suitable for a casing temperature range of $-25^{\circ}C$ to $+115^{\circ}C$.

For applications below $-25^{\circ}C$, NBR sealing rings must be used (permissible temperature range: $-40^{\circ}C$ to $+90^{\circ}C$).

> Effect of Case Pressure on Beginning of Control

An increase in case pressure affects the following control options at the beginning of control of the variable motor:

HD/HA.T _____ increase

HD/HA/HA.T/EP(Size 250) _____ increase

The factory settings for the beginning of control are made at $P_{abs}=0.2MPa$.



► Technical Data

Size	63 Series		Unit	28	55	80	107	160	200	250
Displacement		$V_{g \max}$	mL/r	28.1	54.8	80	107	160	200	250
		V_{gx}	mL/r	18	35	51	68	61	76	205
		$V_{g \min}$	mL/r	0	0	0	0	0	0	0
Maximum speed (In compliance with maximum permissible flow)	$V_{g \max}$	n_{\max}	rpm	5550	4450	3900	3550	3100	2900	2700
	$V_g < V_{gx}$	n_{\max}	rpm	8750	7000	6150	5600	4900	4600	3300
	V_{g0}	n_{\max}	rpm	10450	8350	7350	6300	5500	5100	3300
Max. flow	$n_{\text{nom}} \& V_{g \max}$	$q_{v \max}$	L/min	156	244	312	380	496	580	675
Max. torque	$V_{g \max}$ $\Delta p = 40 \text{MPa}$	T_{\max}	Nm	179	349	509	681	1019	1273	1391
Rotary stiffness	$V_{g \max}$ to $V_g/2$	C_{\min}	KNm/rad	6	10	16	21	35	44	60
	$V_g/2$ to 0	C_{\min}	KNm/rad	18	32	48	65	105	130	181
Moment of inertia of drive shaft		J	kgm ²	0.0014	0.0042	0.0080	0.0127	0.0253	0.0353	0.061
Case volume		V	L	0.5	0.75	1.2	1.5	2.4	2.7	3.0
Weight		m	kg	16	26	34	46	64	80	100

Size	69 Series		Unit	115	130	170	215
Displacement		$V_{g \max}$	mL/r	115.6	130	171.8	216.5
		V_{gx}	mL/r	69	78	65	130
		$V_{g \min}$	mL/r	0	0	0	0
Maximum speed (In compliance with maximum permissible flow)	$V_{g \max}$	n_{\max}	rpm	3550	3200	3100	2900
	$V_g < V_{gx}$	n_{\max}	rpm	6150	5100	4900	4800
	V_{g0}	n_{\max}	rpm	7350	7350	5750	5500
Max. flow	$n_{\text{nom}} \& V_{g \max}$	$q_{v \max}$	L/min	410	416	533	628
Max. torque	$V_{g \max}$ $\Delta p = 40 \text{MPa}$	T_{\max}	Nm	736	828	1094	1378
Rotary stiffness	$V_{g \max}$ to $V_g/2$	C_{\min}	KNm/rad	37	37	52	70
	$V_g/2$ to 0	C_{\min}	KNm/rad	104	104	156	196
Moment of inertia of drive shaft		J	kgm ²	0.0110	0.0110	0.0213	0.0303
Case volume		V	L	1.5	1.5	2.3	2.8
Weight		m	kg	46	46	62	78



➤ Minimum Inlet Pressure at Working Port A(B)

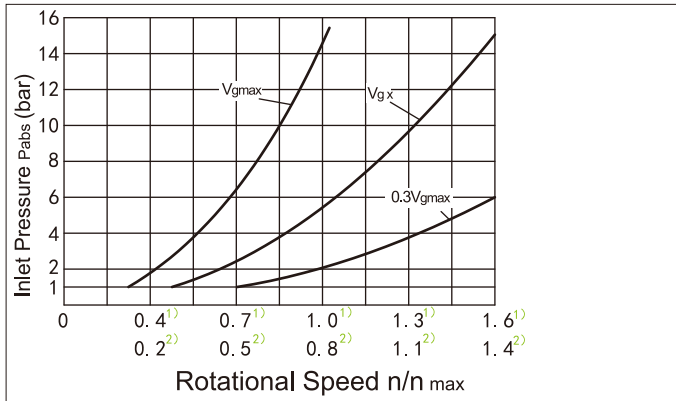

1): Suitable for displacements of 28-215

2): Suitable for displacements of 250

This diagram applies exclusively to the optimal viscosity range at $V_{opt}=36-16\text{mm}^2/\text{s}$.

If the above conditions cannot be met, please contact us.

To prevent damage to the variable motor, a minimum inlet pressure must be ensured at the inlet.

This minimum inlet pressure depends on the speed and swivel angle of the variable motor.

➤ Permissible Displacement in Relation to Rotational Speed

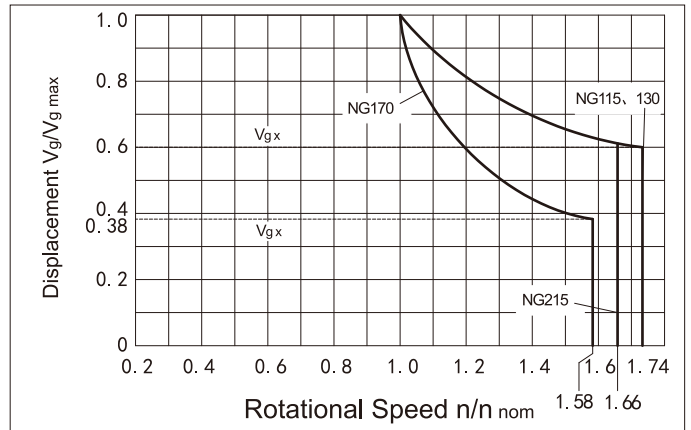
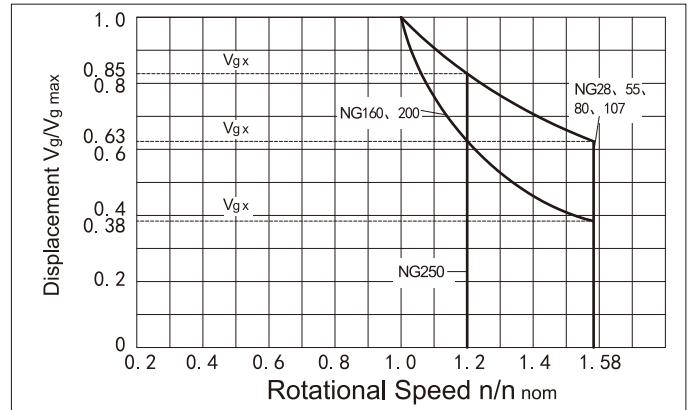

➤ Permissible Radial and Axial Forces of Drive Shaft

Size	Displacement		28		55		80		107		115		130		160		170		200		215		250	
Drive Shaft	Code		A	Z	A	Z	A	Z	A	Z	A	Z	Z	A	Z	A	Z	A	Z	A	A	Z		
		花键轴	W30	W25	W35	W30	W40	W35	W45	W40	W45	W40	W40	W50	W45	W50	W45	W50	W50	W50	W50	W50		
Max. radial force at distance a from shaft collar ¹⁾	$F_q \text{ max}$	N	4838	6436	8069	7581	10283	10266	12215	13758	14851	16727	16727	16435	18278	19080	21220	20532	25016					
	a	mm	17.5	14	20	17.5	22.5	20	25	22.5	25	22.5	22.5	27.5	25	27.5	25	27.5	27.5	27.5	27.5	41		
Permissible torque	T_{max}	Nm	179	179	349	281	509	444	681	681	828	828	828	1019	1019	1200	1200	1273	1550					
Maximum Pressure Differential at $V_{g\text{max}} \& F_{q\text{max}}$	$\Delta p_{q \text{ max}}$	bar	400	400	400	322	400	349	400	400	450	450	450	400	400	440	440	400	450					
Max. axial force ²⁾	$+F_{\text{ax max}}$	N	0	0	0	0	0	0	0	0	0	0	0	0	0	0	0	0	0	0	0	0	0	0
	$-F_{\text{ax max}}$	N	315	315	500	500	710	710	900	900	1300	1300	1300	1120	1120	1120	1120	1250	1250	1250	1250	1200		
Permissible axial force/bar Working pressure/bar	$+F_{\text{ax perm/bar}}$	N/bar	4.6	4.6	7.5	7.5	9.6	9.6	11.3	11.3	13.3	13.3	13.3	15.1	15.1	15.1	15.1	17	17					

1): Intermittent operation;

2): Max. permissible axial force when the axial piston motor is stationary or working under no pressure.

➤ Specification Calculation

Input flow $q_v = \frac{V_g \cdot n}{1000 \cdot \eta_v}$ [L/min]

V_g = Displacement, mL/r

Torque $T = \frac{V_g \cdot \Delta p \cdot \eta_{mh}}{2 \cdot \pi}$ [Nm]

Δp = Differential pressure, MPa

n = Speed, rpm

Power $P = \frac{2 \pi \cdot T \cdot n}{60000} = \frac{q_v \cdot \Delta p \cdot \eta_t}{60}$ [KW]

η_v = Volumetric efficiency

η_{mh} = Mechanical-hydraulic efficiency

Speed $n = \frac{q_v \cdot 1000 \cdot \eta_v}{V_g}$ [rpm]

η_t = Total efficiency



Control Device-HD Proportional Hydraulic Control

The hydraulic system related to pilot pressure allows infinite change of motor displacement with pilot pressure signal. The displacement is proportional to the pilot pressure at port X.

Standard configuration:

- Beginning of control at $V_{g \max}$ (max. torque, min. speed)
- End of control at $V_{g \min}$ (min. torque, max. permissible speed)

Note:

- Maximum permissible pilot pressure=10MPa
- For stable control, a working pressure of at least 3MPa is required at port A(B). If control is made at a working pressure below 3MPa, an auxiliary pressure of at least 3MPa must be applied at port G using an external check valve. Lower pressures may be needed in certain cases.
- Specify the setting of beginning of control in plain text when ordering, e.g.: beginning of control = 1MPa.

HD1 pilot pressure increase $\Delta p_s=1\text{MPa}$

A pilot pressure increase of 1MPa at port X will cause displacement to fall from $V_{g \max}$ to 0mL/r.

Beginning of control (setting range) 0.2-2MPa

Standard setting: beginning of control at 0.3MPa (end of control at 1.3MPa)

HD1 Characteristic curve

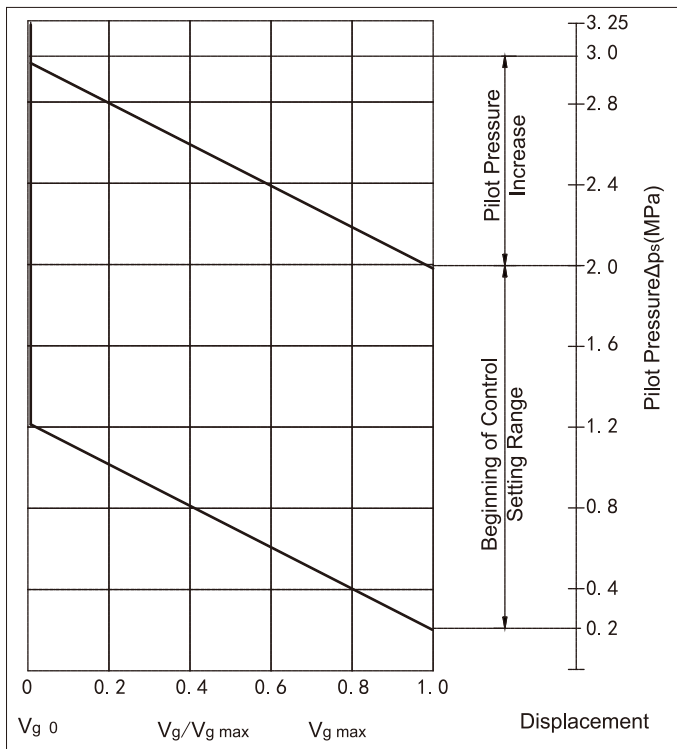

HD2 pilot pressure increase $\Delta p_s=2.5\text{MPa}$

A pilot pressure increase of 2.5MPa at port X will cause displacement to fall from $V_{g \max}$ to 0mL/r.

Beginning of control (setting range) 0.5-5MPa

Standard setting: beginning of control at 1MPa (end of control at 3.5MPa)

HD2 Characteristic curve

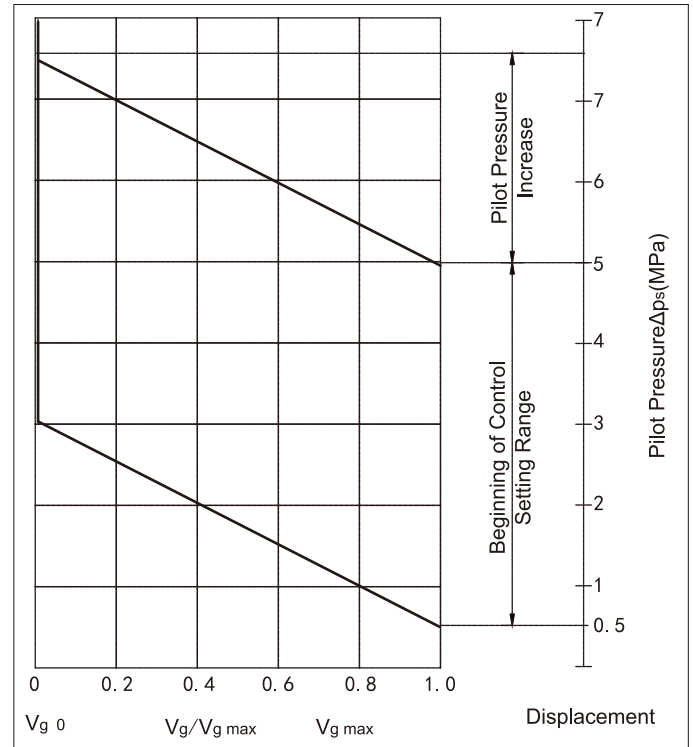

HD1/HD2 Hydraulic control circuit diagram

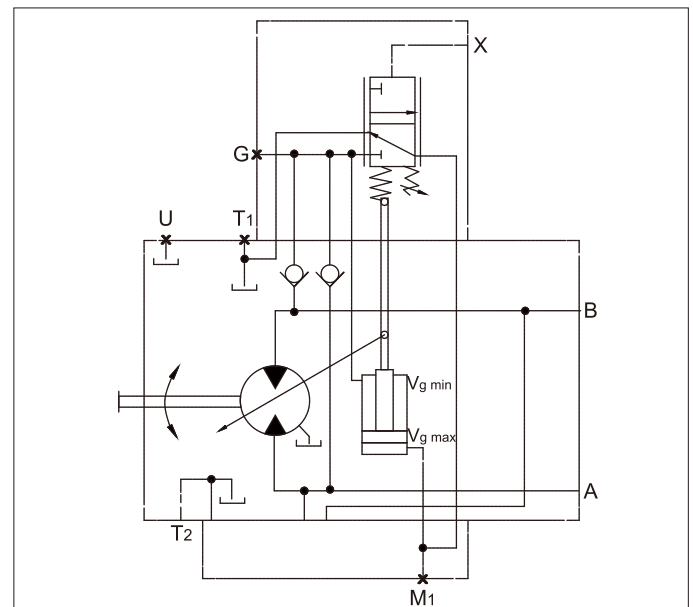

Note

The returning spring in the control device does not serve as a safety device. In the case of internal contamination (e.g. impurities in hydraulic fluid, worn system components or residual pollutant), the control spool and/or positioning piston may get stuck in any position. This may cause failure of the variable motor to provide the required speed and torque.

- Install a suitable emergency stop to ensure safety of the driven load (e.g. prompt stop).
- Maintain a cleanliness level of 20/18/15 (<90 °C) or 19/17/14 (>90 °C) according to ISO 4406.



> HD.D Pressure Control, Fixed Setting

Pressure control overrides HD functions. If the load torque or a reduction in motor swivel angle causes the system pressure to rise and reach the set point of the pressure control, the motor will swivel towards a larger angle.

The increase in displacement and reduction in pressure cause the control deviation to decrease. By increasing the displacement, the motor develops more torque at constant pressure.

Setting range of pressure control valve: 8-40 MPa

HD.D Hydraulic control circuit diagram-displacement 28-200

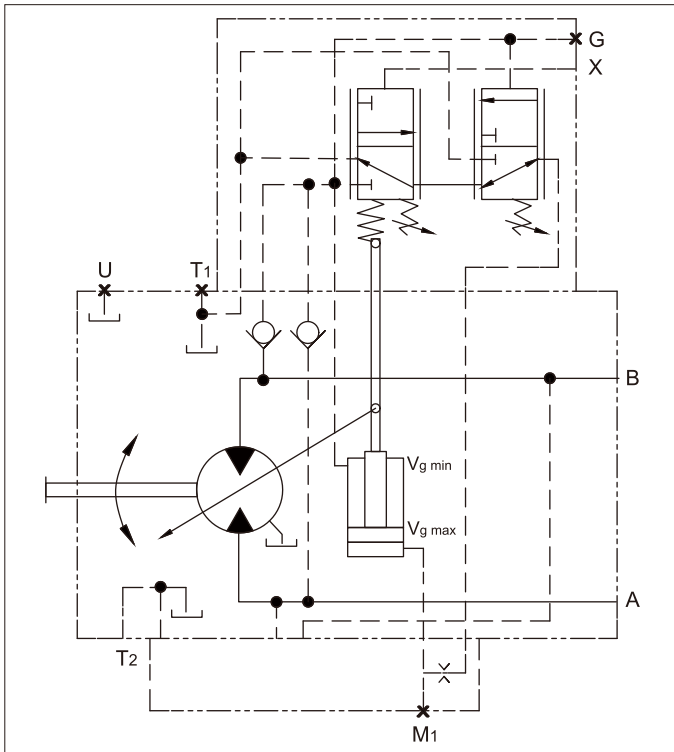



Control Device - HZ Two-point Hydraulic Control

The two-point hydraulic control allows the displacement to be set to $V_{g \min}$ or $V_{g \max}$ by switching on or off the pilot pressure at port X.

Standard configuration:

- Beginning of control at $V_{g \max}$
(without pilot pressure, max. torque, min. speed)
- End of control at $V_{g \min}$
(pilot pressure > 1MPa, min. torque, max. speed)

HZ Characteristic curve

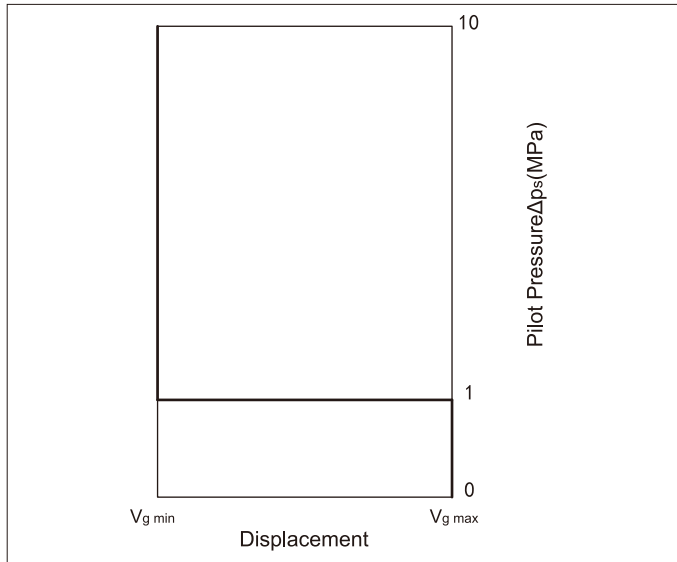

Note

- Maximum permissible pilot pressure $\Delta p_s = 10 \text{ MPa}$
- For stable control, a working pressure of at least 3MPa is required at port A(B). If control is made at a working pressure below 3MPa, an auxiliary pressure of at least 3MPa must be applied at port G using an external check valve. For lower pressures, please contact us;
- Please note that a pressure up to 45MPa can occur at port G

HZ1 Hydraulic control circuit diagram -displacement 28/107/115/130/160/170/200

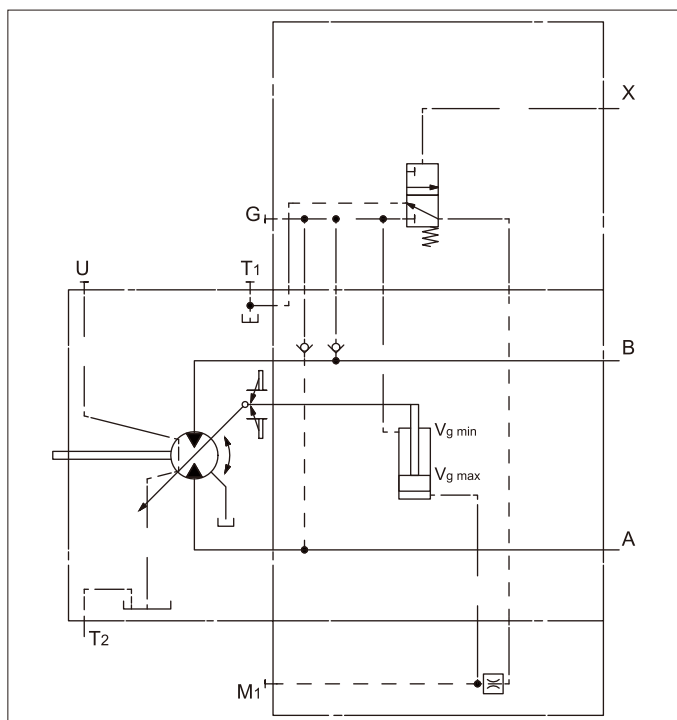

HZ3 Hydraulic control circuit diagram-displacement 55/80

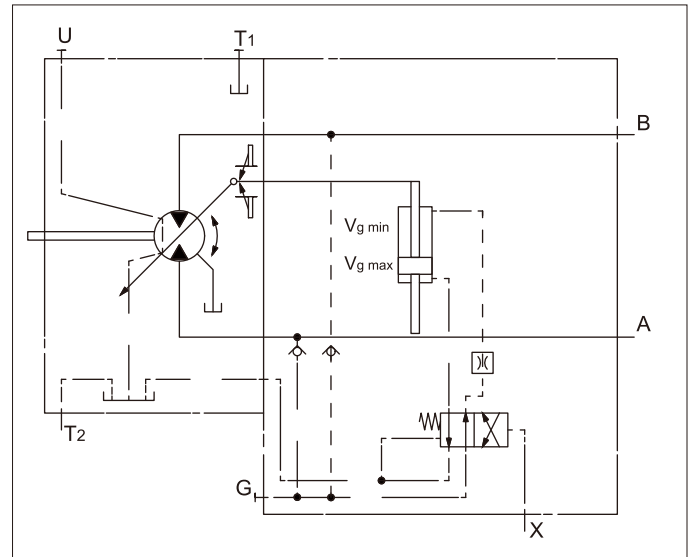

HZ1.D Two-point Hydraulic Control, Fixed Control

Pressure control overrides HZ functions. If the load torque or a reduction in motor swivel angle causes the system pressure to rise and reach the set point of the pressure control, the motor will swivel towards a larger angle. The increase in displacement and reduction in pressure cause the control deviation to decrease. By increasing the displacement, the motor develops more torque at constant pressure.

Setting range of pressure control valve: 8-40MPa

HZ1.D Hydraulic control circuit diagram -displacement 107-200

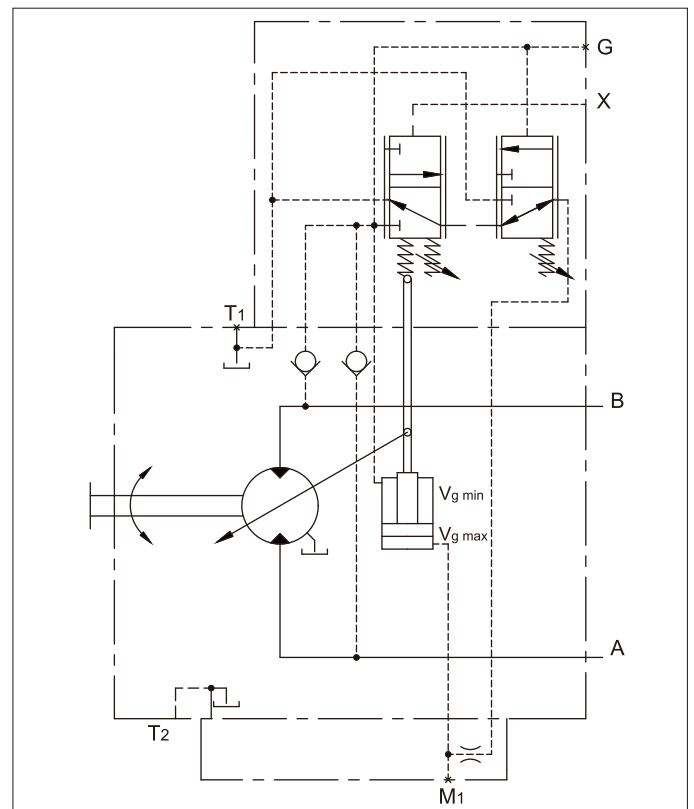



➤ Control Device-EP Electric Control with Proportional Solenoid

The electric control with proportional solenoid allows infinite setting of motor displacement with electric signals. Control is proportional to the current applied to the solenoid.

Standard configuration:

- Beginning of control at $V_{g \max}$ (max. torque, min. speed)
- End of control at $V_{g \min}$ (min. torque, max. permissible speed)

EP Characteristic curve

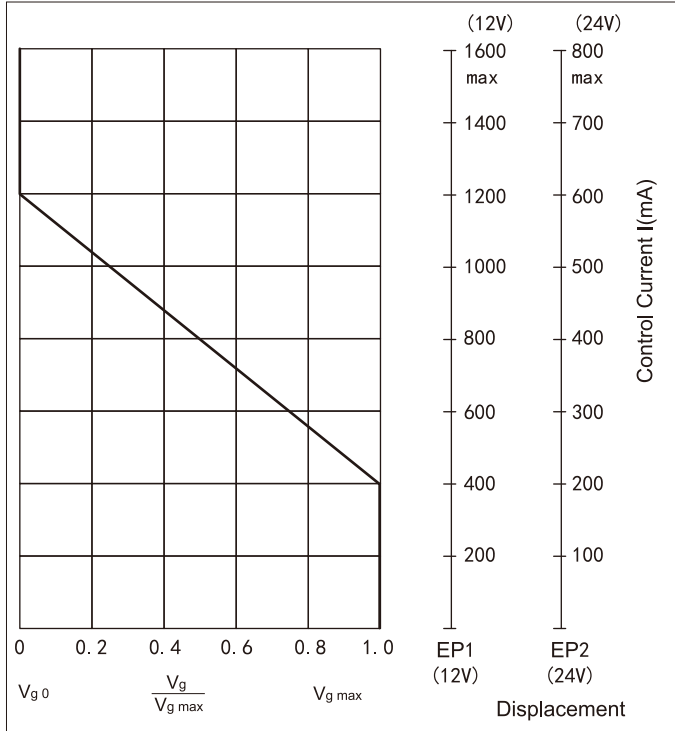

Note

For stable control, a working pressure of at least 3 MPa is required at port A(B). If control is made at a working pressure < 3 MPa, an auxiliary pressure of at least 3 MPa must be applied at port G using an external check valve. Lower pressures may be needed in certain cases.

Technical data, EP1/EP2 solenoid

	EP1	EP2
Voltage	12V ($\pm 20\%$)	24V ($\pm 20\%$)
Control current		
Beginning of control at $V_{g \max}$	400mA	200mA
Beginning of control at $V_{g \min}$	1200mA	600mA
Current limit	1.54A	0.77A
Nominal resistance(20°C)	5.5Ω	22.7Ω
Dither frequency	100Hz	100Hz
Duty cycle	100%	100%
Type of protection	IP65	

The returning spring in the control device does not serve as a safety device.

In the case of internal contamination (e.g. impurities in hydraulic fluid, worn system components or residual pollutant), the control spool and/or positioning piston may get stuck in any position. This may cause failure of the variable motor to provide the required speed and torque.

- Install a suitable emergency stop to ensure safety of the driven load (e.g. prompt stop)
- Maintain a cleanliness level of 20/18/15 (<90 °C) or 19/17/14 (>90 °C) according to ISO 4406

EP1/EP2 Hydraulic control circuit diagram-displacement 28-200

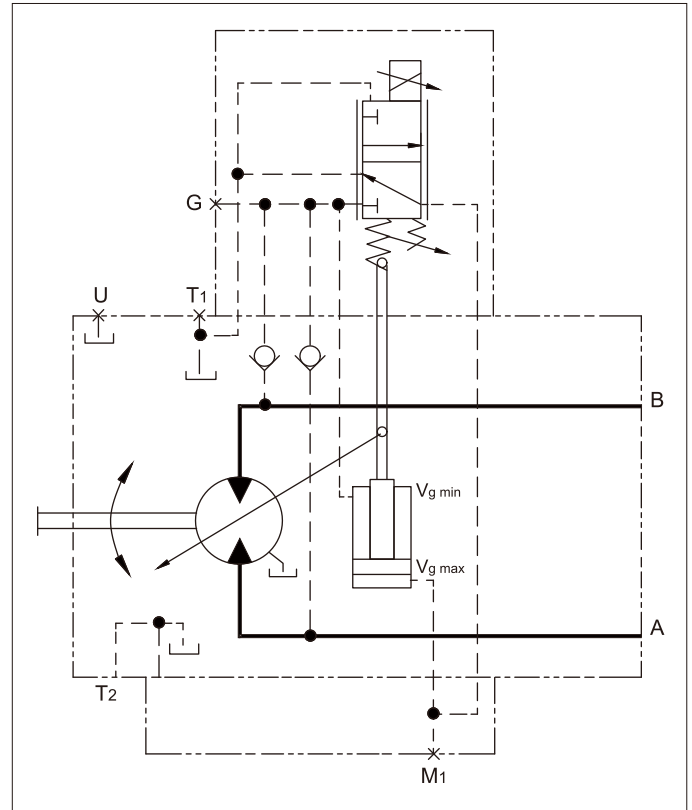



➤ EP.D Electric Control, Fixed Setting

Pressure control overrides EP functions. If the load torque or a reduction in motor swivel angle causes the system pressure to rise and reach the set point of the pressure control, the motor will swivel towards a larger angle. The increase in displacement and reduction in pressure cause the control deviation to decrease. By increasing the displacement, the motor develops more torque at constant pressure.

Setting range of pressure control valve: 8-40 MPa

EP.D Hydraulic control circuit diagram

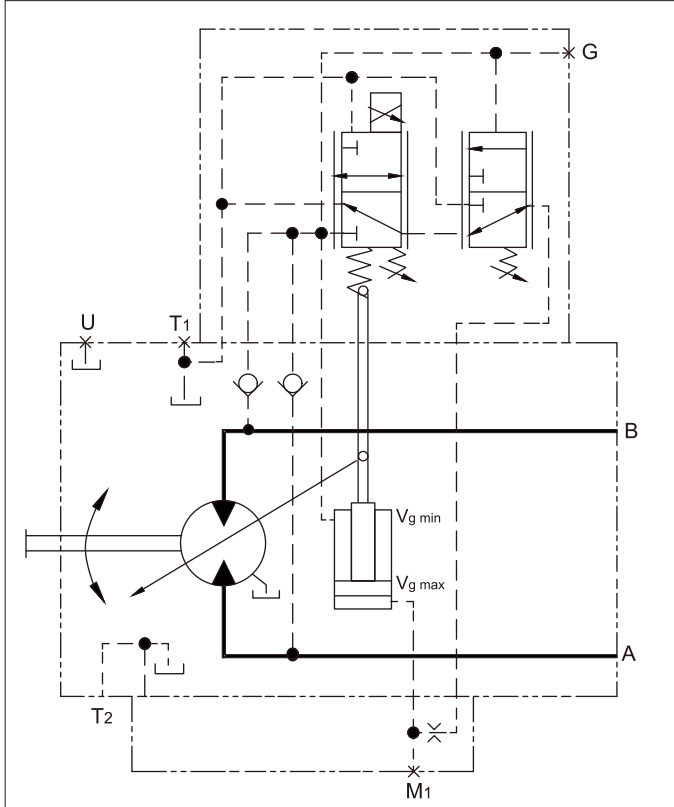



> Control Device-EZ Electric Control with Switching Solenoid

The electric control with switching solenoid allows the displacement to reach $V_{g \max}$ or $V_{g \min}$ by switching on or off a switching solenoid or an on/off valve.

Note:

- For stable control, a working pressure of at least 3 MPa is required at port A(B). If control is made at a working pressure < 3 MPa, an auxiliary pressure of at least 3 MPa must be applied at port G using an external check valve. Lower pressures may be needed in certain cases.

Technical data, EZ1/EZ2 solenoid with Ø37

28/107/115/130/160/170/200	EZ1	EZ2
Voltage	12V ($\pm 20\%$)	24V ($\pm 20\%$)
Neutral position $V_{g \max}$	De-energized	De-energized
Position $V_{g \min}$	Energized	Energized
Nominal resistance(20°C)	5.5Ω	21.7Ω
Rated output	26.2W	26.5W
Min. active current required	1.32A	0.67A
Duty cycle	100%	100%
Type of protection	IP65	

Technical data, EZ3/EZ4solenoid with Ø45

55/80	EZ3	EZ4
Voltage	12V ($\pm 20\%$)	24V ($\pm 20\%$)
Neutral position $V_{g \max}$	De-energized	De-energized
Position $V_{g \min}$	Energized	Energized
Nominal resistance(20°C)	4.8Ω	19.2Ω
Rated output	30W	30W
Min. active current required	1.5A	0.75A
Duty cycle	100%	100%
Type of protection	IP65	

EZ1/EZ2 Hydraulic control circuit diagram -displacement 28/107/115/130/160/170/200

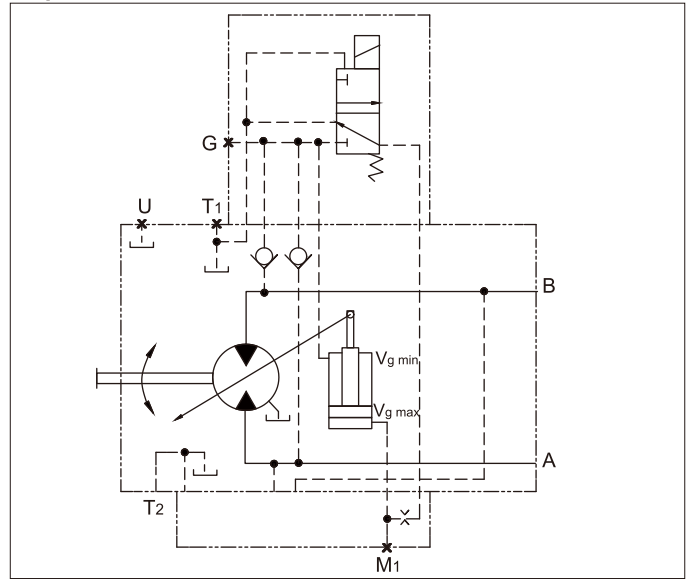

EZ3/EZ4 Hydraulic control circuit diagram-displacement 55/80

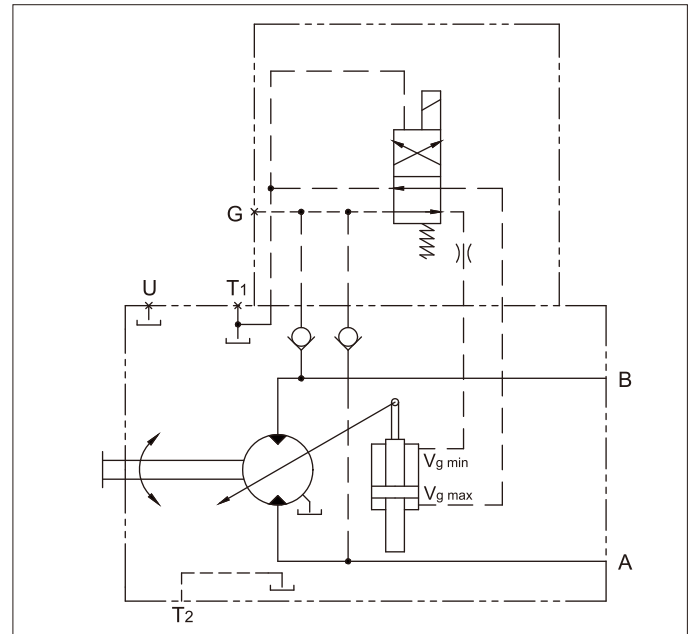



➤ EZ.D Electric Control with Switching Solenoid, Fixed Setting

Pressure control overrides EZ functions. If the load torque or a reduction in motor swivel angle causes the system pressure to rise and reach the set point of the pressure control, the motor will swivel towards a larger angle. The increase in displacement and reduction in pressure cause the control deviation to decrease. By increasing the displacement, the motor develops more torque at constant pressure.

Setting range of pressure control valve: 8-40 MPa

EZ.D Hydraulic control circuit diagram-displacement 107-200

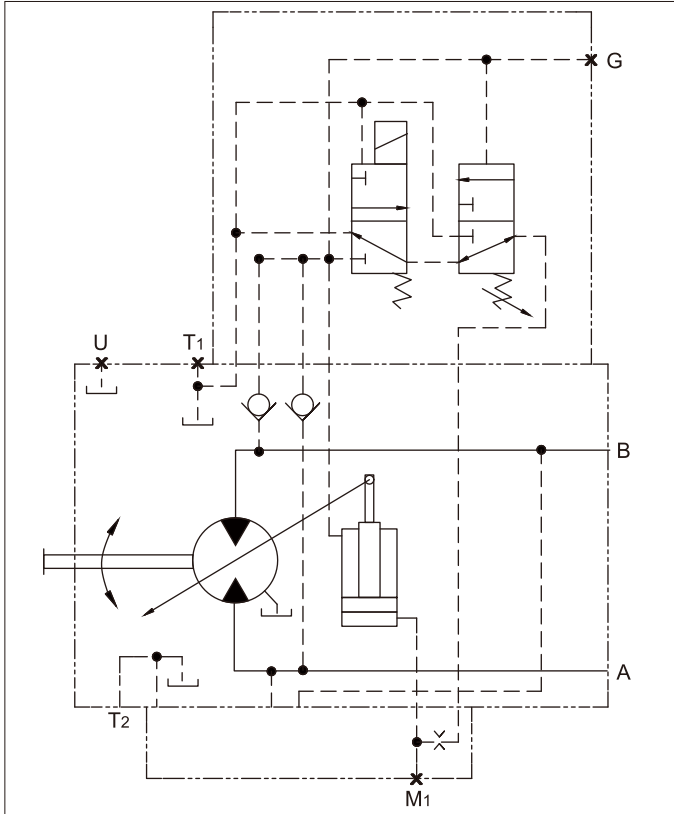



➤ Control Device-HA Automatic Control, High Voltage Related

The high-pressure related automatic control adjusts motor displacement automatically based on working pressure. The control device measures internally the working pressure at port A or B (no control line required). Once it reaches the set pressure value of the control, the motor swivels from the minimum displacement $V_{g \min}$ to the maximum displacement $V_{g \max}$ with the increasing working pressure.

Standard configuration:

- Beginning of control at $V_{g \min}$ (min. torque, max. speed)
- End of control at $V_{g \max}$ (max. torque, min. speed)

HA1 with minimum increase $\Delta p = 1 \text{MPa}$

A working pressure increase of $\Delta p \leq 1 \text{MPa}$ results in an increase of displacement from 0 to $V_{g \max}$.

Setting range of beginning of control: 8-35MPa

Please specify the setting of beginning of control in plain text when ordering, e.g.: beginning of control = 30MPa.

Please note:

- For safety reasons, when the control start point is at $V_{g \min}$ (standard HA configuration), this control mode is not permitted for use with winch gearboxes.
- To ensure stable control, a working pressure of at least 3 MPa is required at port A (or B). If control is needed at a working pressure below 3 MPa, an auxiliary pressure of at least 3 MPa must be applied to port G via an external check valve.

HA1 Characteristic curve

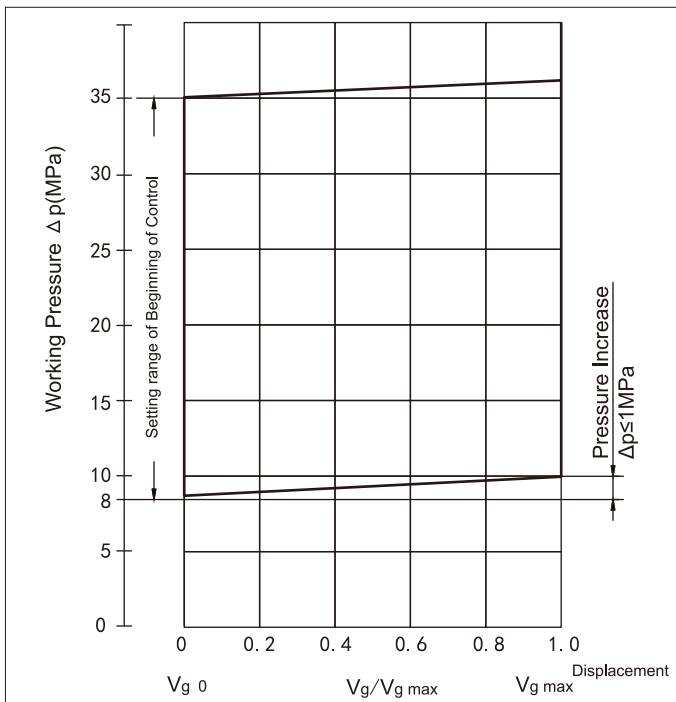

HA1 Hydraulic control circuit diagram

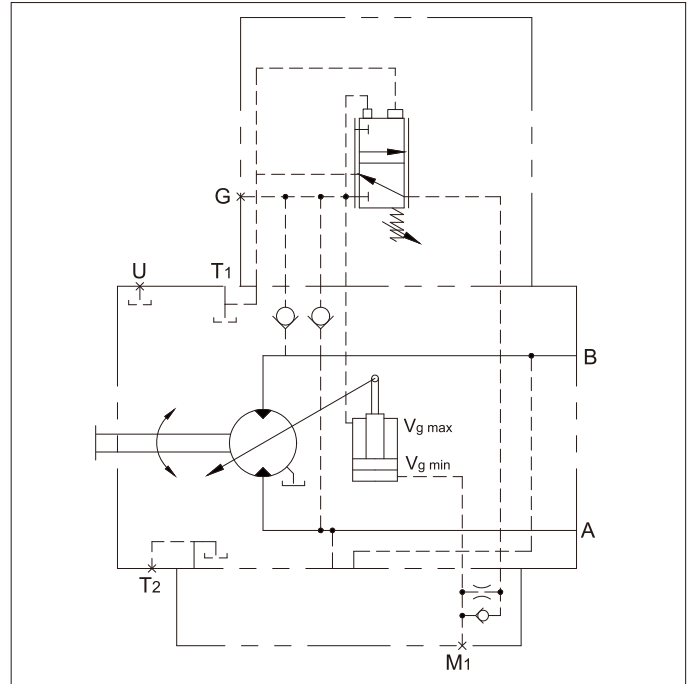



HA2 with pressure increase $\Delta p=10\text{MPa}$

A working pressure increase of $\Delta p \leq 10\text{MPa}$ results in an increase of displacement from 0 to $V_{g \text{ max}}$.

Setting range of beginning of control: 8-35MPa

Please specify the setting of beginning of control in plain text when ordering, e.g.: beginning of control = 20MPa.

HA2 Characteristic curve

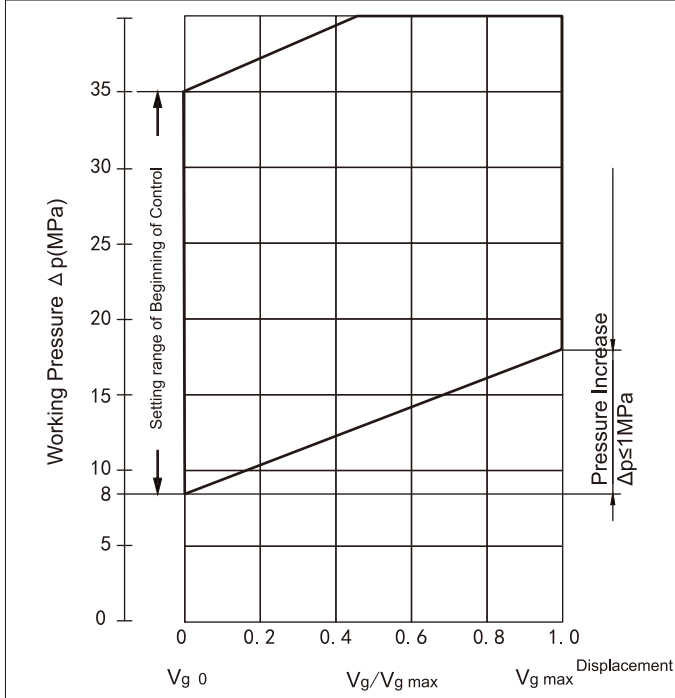

HA2 Hydraulic control circuit diagram

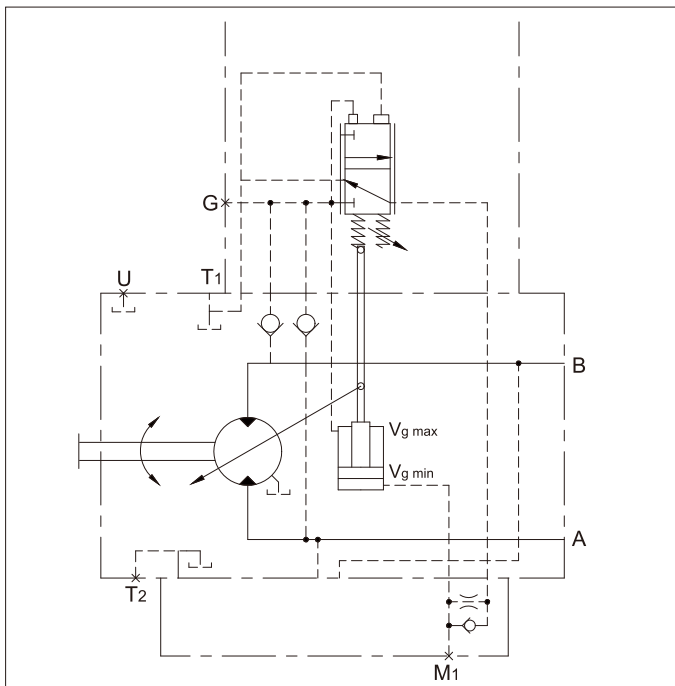



➤ HA.T Hydraulic Override Control, Remote Control, Proportional Control

With HA.T control, the beginning of control may be changed by applying pilot pressure to port X.

For every 0.1 MPa of pilot pressure, the beginning of control is reduced by 1.7 MPa.

Example:

Setting for beginning of control	30MPa	30MPa
Pilot pressure at port X	0MPa	1MPa
Beginning of control	30MPa	13MPa

HA1.T Hydraulic control circuit diagram

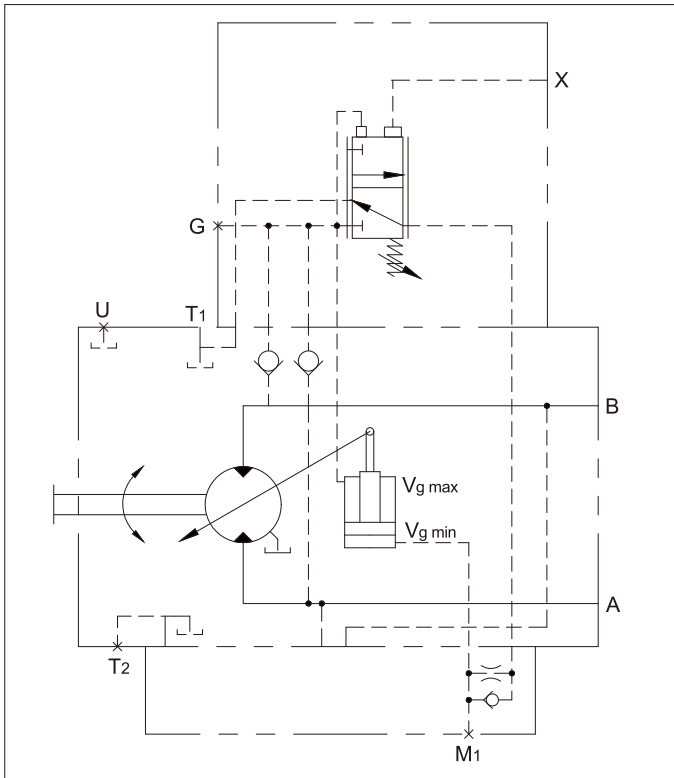

HA2.T Hydraulic control circuit diagram

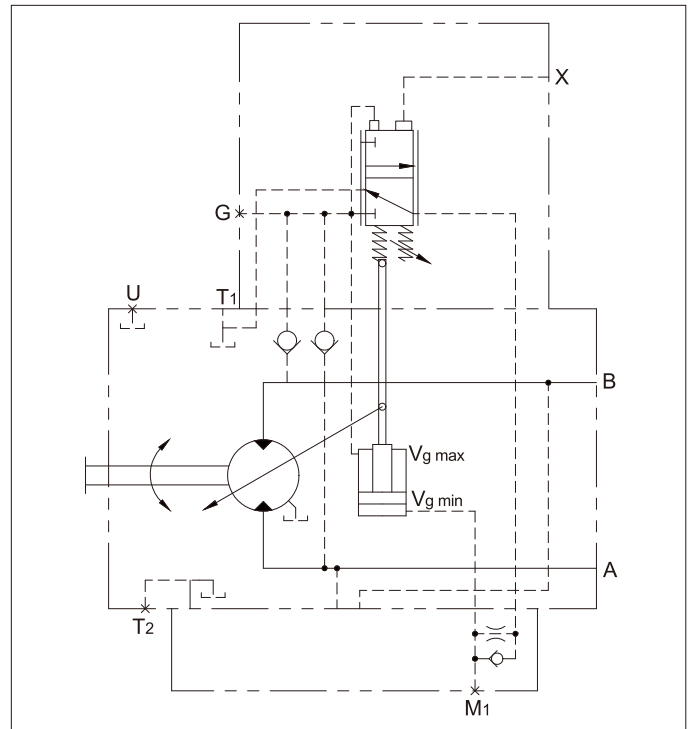



► Installation Dimensions, Size 55

EP1/EP2 electrical proportional control
SAE flange ports A/B at side, opposite(02)

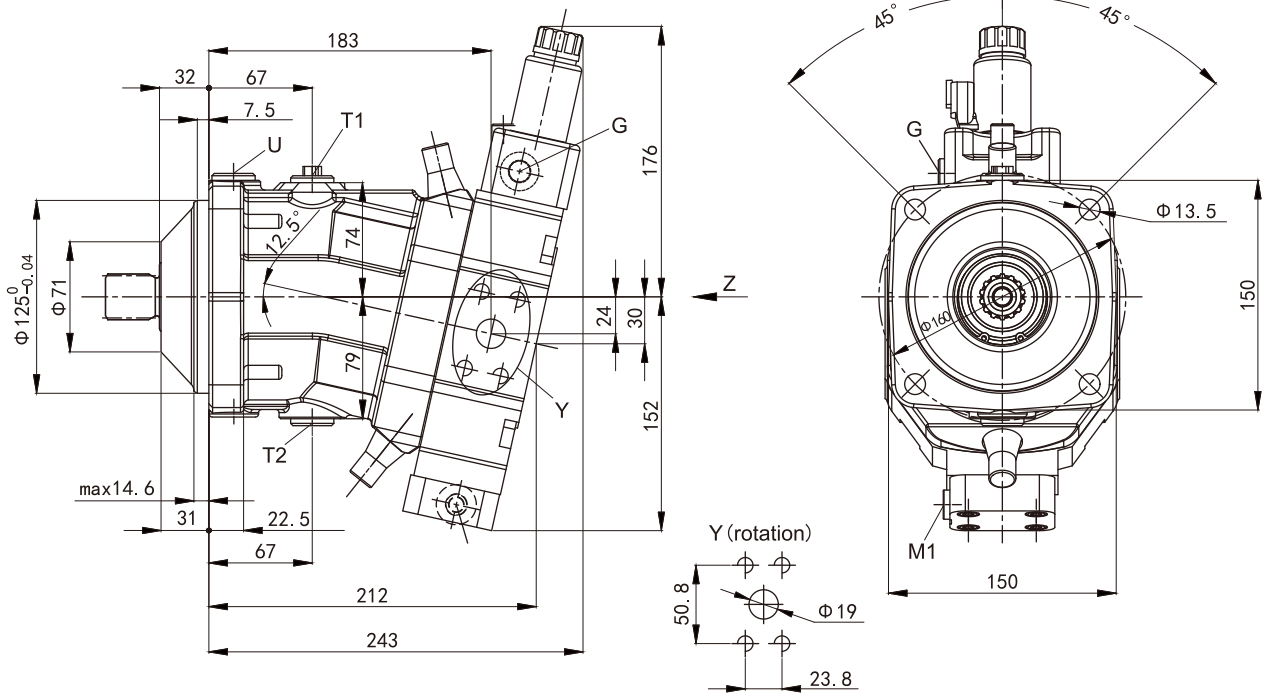

Ports	Usage	Standard	Specifications ¹⁾	Max.pressure ²⁾	State ⁶⁾
A/B	Working port	SAE J518 ³⁾	3/4"	450	○
	Fastening thread A/B	DIN 13	M10×1.5; 17deep		
T1	Case drain port	DIN 3852 ⁵⁾	M18×1.5; 12deep	3	○ ⁴⁾
T2	Case drain port	DIN 3852 ⁵⁾	M18×1.5; 12deep	3	× ⁴⁾
G	Synchronous Contro	DIN 3852 ⁵⁾	M14×1.5; 12deep	450	×
G2	Secondary pressure setting(HD.E、 EP.E)	DIN 3852 ⁵⁾	M14×1.5; 12deep	100	×
U	Flushing port	DIN 3852 ⁵⁾	M18×1.5; 12deep	3	×
X	Pilot signal(HD、 HZ、 HA1T/HA2T)	DIN 3852 ⁵⁾	M14×1.5; 12deep	100	○
M1	Control pressure measurement	DIN 3852 ⁵⁾	M14×1.5; 12deep	450	×

- 1): Regarding maximum tightening torque, refer to the safety instructions.
- 2): Depending on the application, instantaneous pressure peaks may occur.
This must be considered when selecting measuring equipment and accessories.
- 3): Dimensions are exclusively according to SAE J518. Metric fastening threads deviate from standard threads.
- 4): Depending on the mounting position, port T1 or T2 must be connected (see also installation instructions).
- 5): Counterbores may be deeper than specified in the relevant standard.
- 6): O=Needs to be connected (comes plugged) X=Plugged (in normal operation)



► Installation Dimensions, Size 55

Detail Z

SAE flange ports A/B at side, opposite(02)

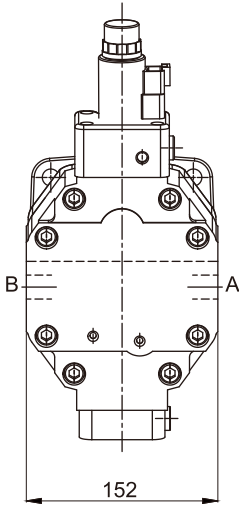

SAE flange ports A/B at rear, opposite(01)

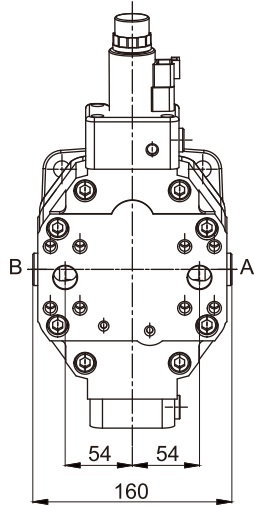

SAE flange ports A/B at side, opposite (02), only for HZ3/EZ3/EZ4

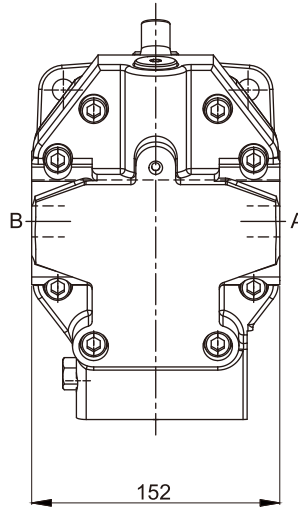

SAE flange ports A/B at rear, opposite (01), only for HZ3、EZ3、EZ4

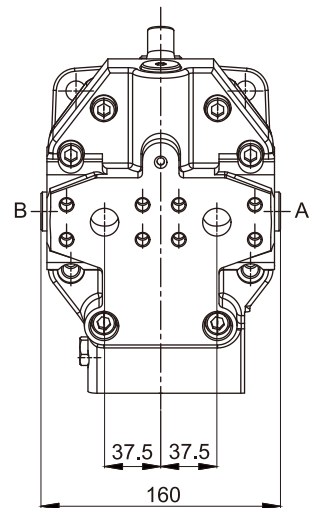

Splined shaft DIN 5480

Z-W30×2×30×14×9g

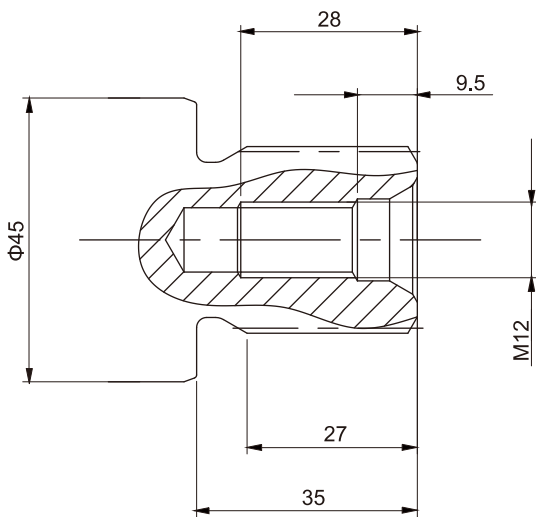

Splined shaft DIN 5480

A-W35×2×30×16×9g

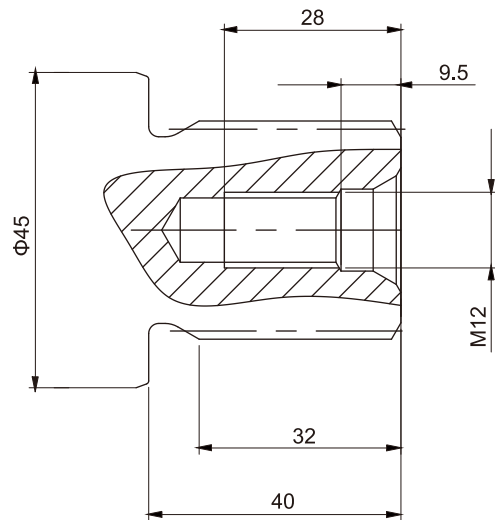



► Installation Dimensions, Size 80

EP1/EP2 electrical proportional control
SAE flange ports A/B at side, opposite(02)

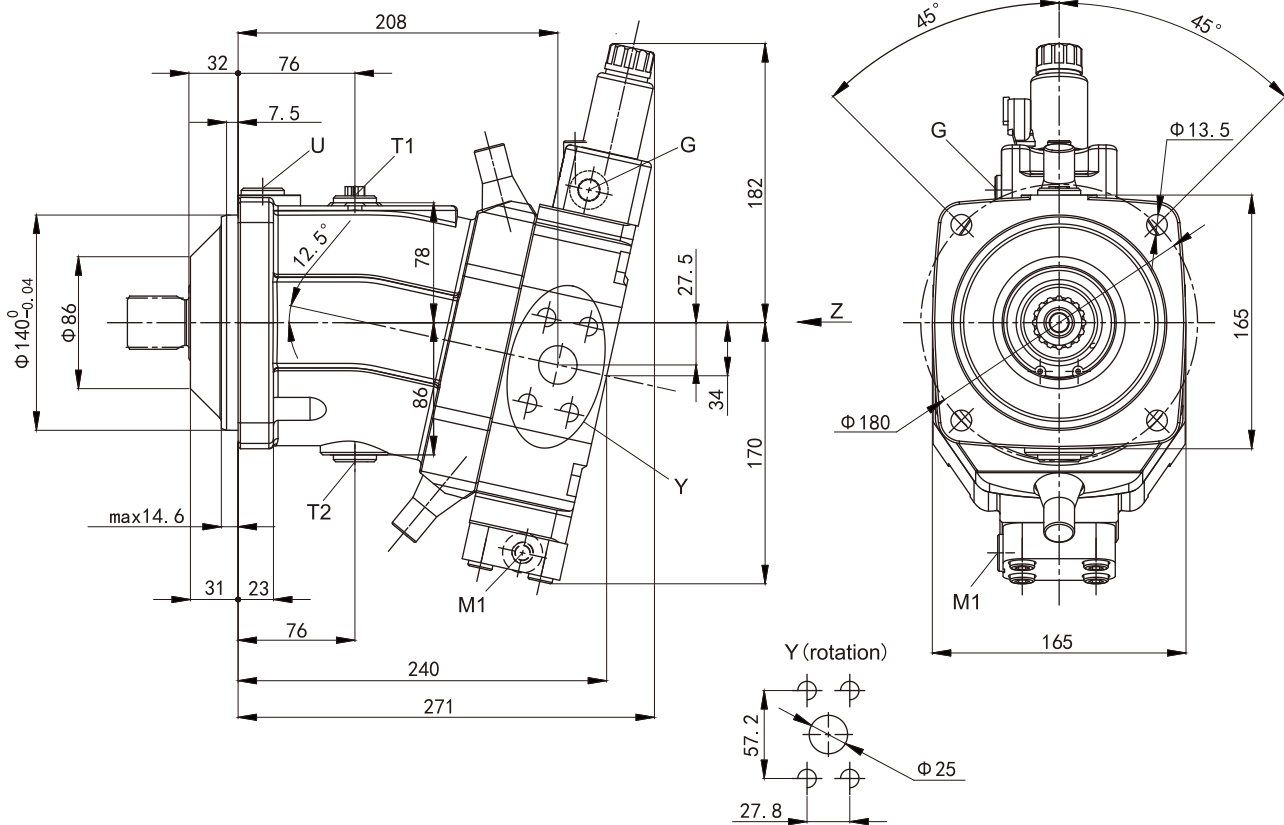

Ports	Usage	Standard	Specifications ¹⁾	Max.pressure ²⁾	State ⁶⁾
A/B	Working port	SAE J518 ³⁾	1"	450	○
	Fastening thread A/B	DIN 13	M12×1.75; 17deep		
T1	Case drain port	DIN 3852 ⁵⁾	M18×1.5; 12deep	3	○ ⁴⁾
T2	Case drain port	DIN 3852 ⁵⁾	M18×1.5; 12deep	3	× ⁴⁾
G	Synchronous Control	DIN 3852 ⁵⁾	M14×1.5; 12deep	450	×
U	Flushing port	DIN 3852 ⁵⁾	M18×1.5; 12deep	3	×
X	Pilot signal(HD、HZ、HA1T/HA2T)	DIN 3852 ⁵⁾	M14×1.5; 12deep	100	○
M1	Control pressure measurement	DIN 3852 ⁵⁾	M14×1.5; 12deep	450	×

- 1): Regarding maximum tightening torque, refer to the safety instructions.
- 2): Depending on the application, instantaneous pressure peaks may occur. This must be considered when selecting measuring equipment and accessories.
- 3): Dimensions are exclusively according to SAE J518. Metric fastening threads deviate from standard threads.
- 4): Depending on the mounting position, port T1 or T2 must be connected (see also installation instructions).
- 5): Counterbores may be deeper than specified in the relevant standard.
- 6): O=Needs to be connected (comes plugged) X=Plugged (in normal operation)



► Installation Dimensions, Size 80

Detail Z

SAE flange ports A/B at side, opposite(02)

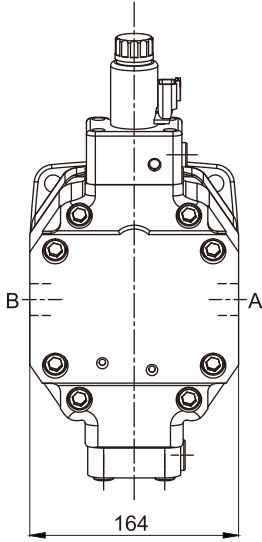

SAE flange ports A/B at rear, opposite(01)

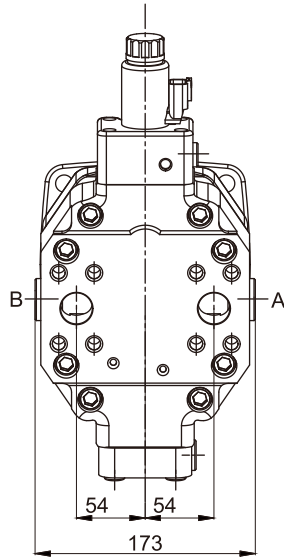

SAE flange ports A/B at side, opposite (02), only for HZ3/EZ3/EZ4

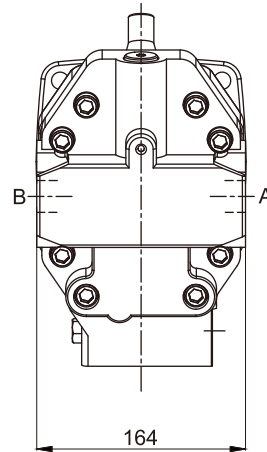

SAE flange ports A/B at rear, opposite (01), only for HZ3- EZ3- EZ4

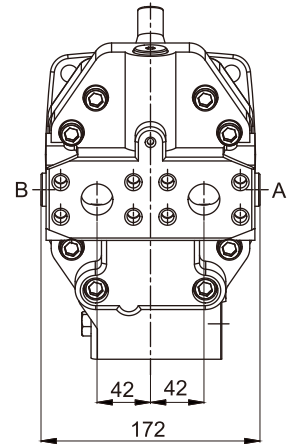

Splined shaft DIN 5480

A-W40×2×30×18×9g

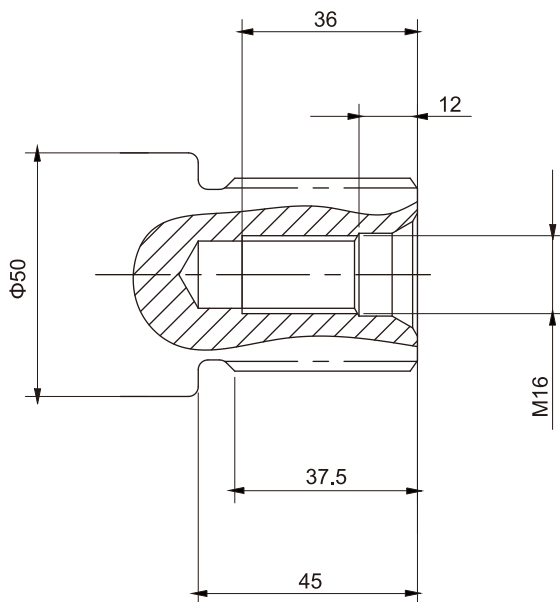

Splined shaft DIN 5480

Z-W35×2×30×16×9g

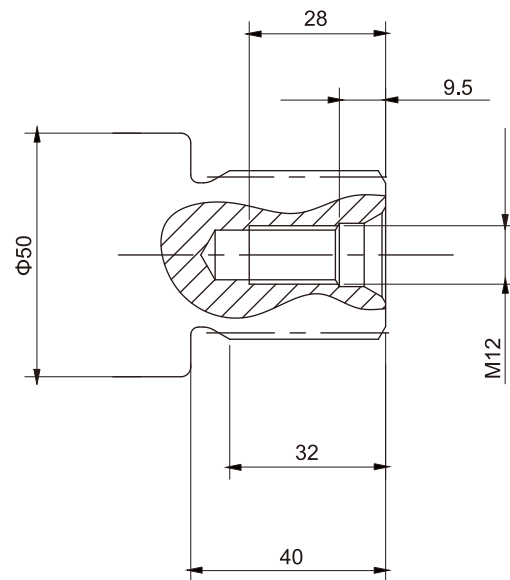



► Installation Dimensions, Size 107/115/130

EP.D electrical proportional control, with Fixed-Setting Pressure Control
SAE flange ports A/B at side, opposite(02)

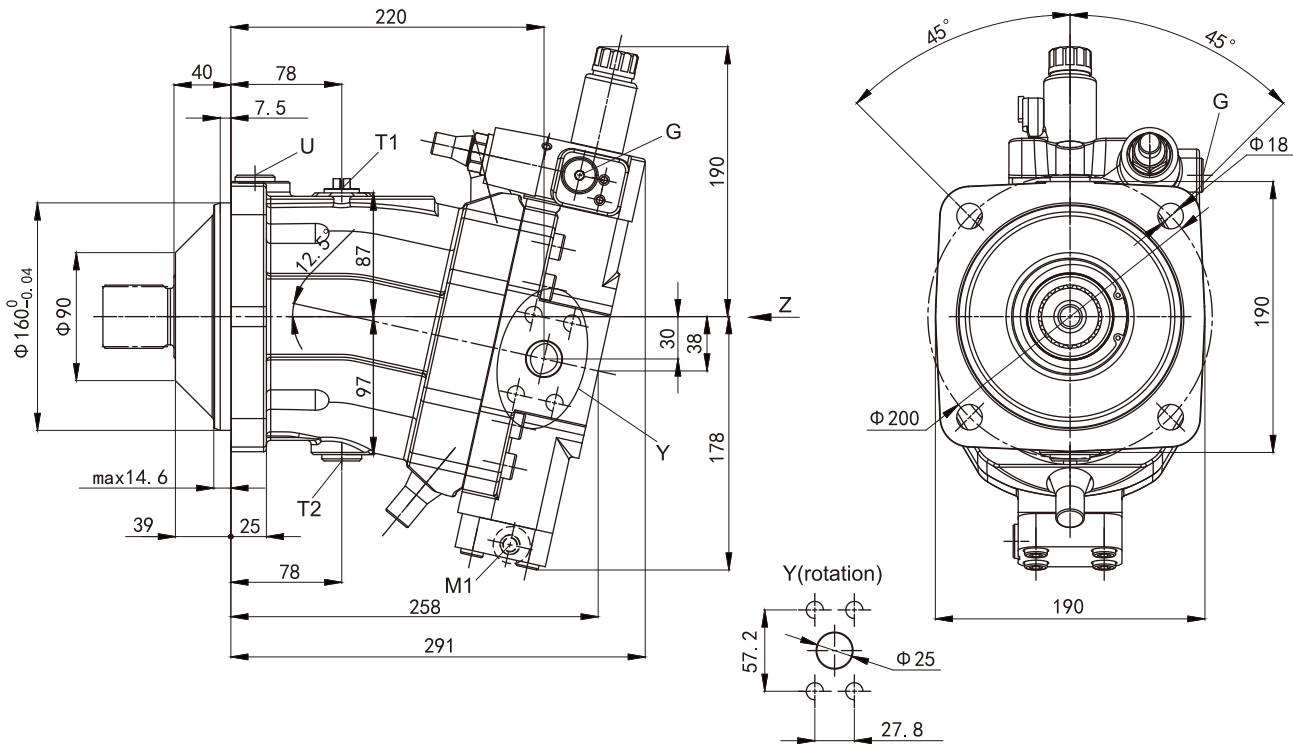

Ports	Usage	Standard	Specifications ¹⁾	Max.pressure ²⁾	State ⁶⁾
A/B	Working port	SAE J518 ³⁾	1"	450	○
	Fastening thread A/B	DIN 13	M12×1.75; 17deep		
T1	Case drain port	DIN 3852 ⁵⁾	M18×1.5; 12deep	3	○ ⁴⁾
T2	Case drain port	DIN 3852 ⁵⁾	M18×1.5; 12deep	3	× ⁴⁾
G	Synchronous Contro	DIN 3852 ⁵⁾	M14×1.5; 12deep	450	×
U	Flushing port	DIN 3852 ⁵⁾	M18×1.5; 12deep	3	×
X	Pilot signal(HD、HZ、HA1T/HA2T)	DIN 3852 ⁵⁾	M14×1.5; 12deep	100	○
M1	Control pressure measurement	DIN 3852 ⁵⁾	M14×1.5; 12deep	450	×

- 1): Regarding maximum tightening torque, refer to the safety instructions.
- 2): Depending on the application, instantaneous pressure peaks may occur. This must be considered when selecting measuring equipment and accessories.
- 3): Dimensions are exclusively according to SAE J518. Metric fastening threads deviate from standard threads.
- 4): Depending on the mounting position, port T1 or T2 must be connected (see also installation instructions).
- 5): Counterbores may be deeper than specified in the relevant standard.
- 6): O=Needs to be connected (comes plugged) X=Plugged (in normal operation)



► Installation Dimensions, Size 107/115/130

Detail Z

SAE flange ports A/B at rear, opposite(01)

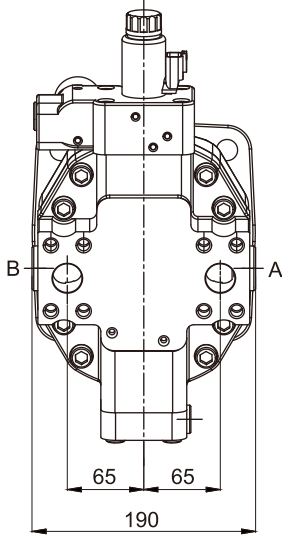

SAE flange ports A/B at side, opposite(02)

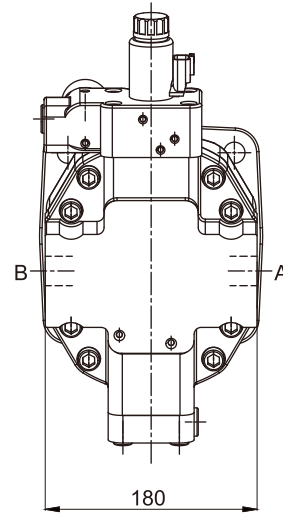

Splined shaft DIN 5480

A-W45×2×30×21×9g

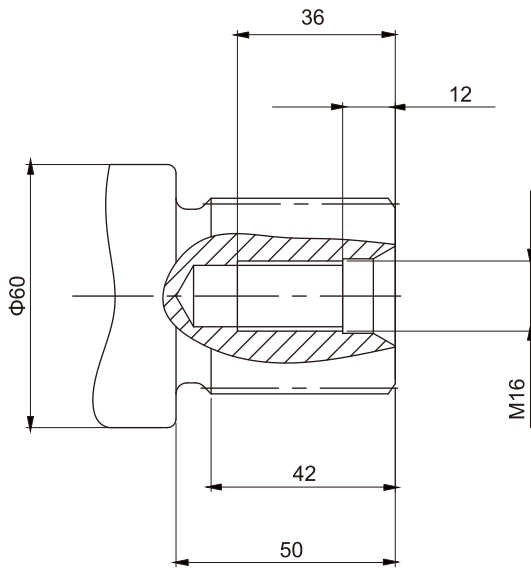

Splined shaft DIN 5480

Z-W40×2×30×18×9g

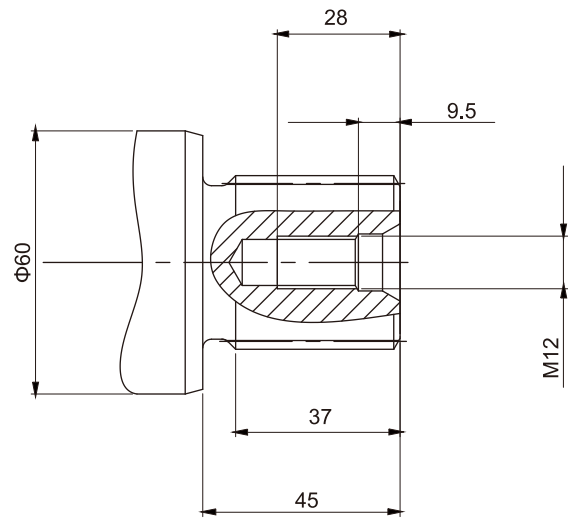



► Installation Dimensions, Size 107/115/130

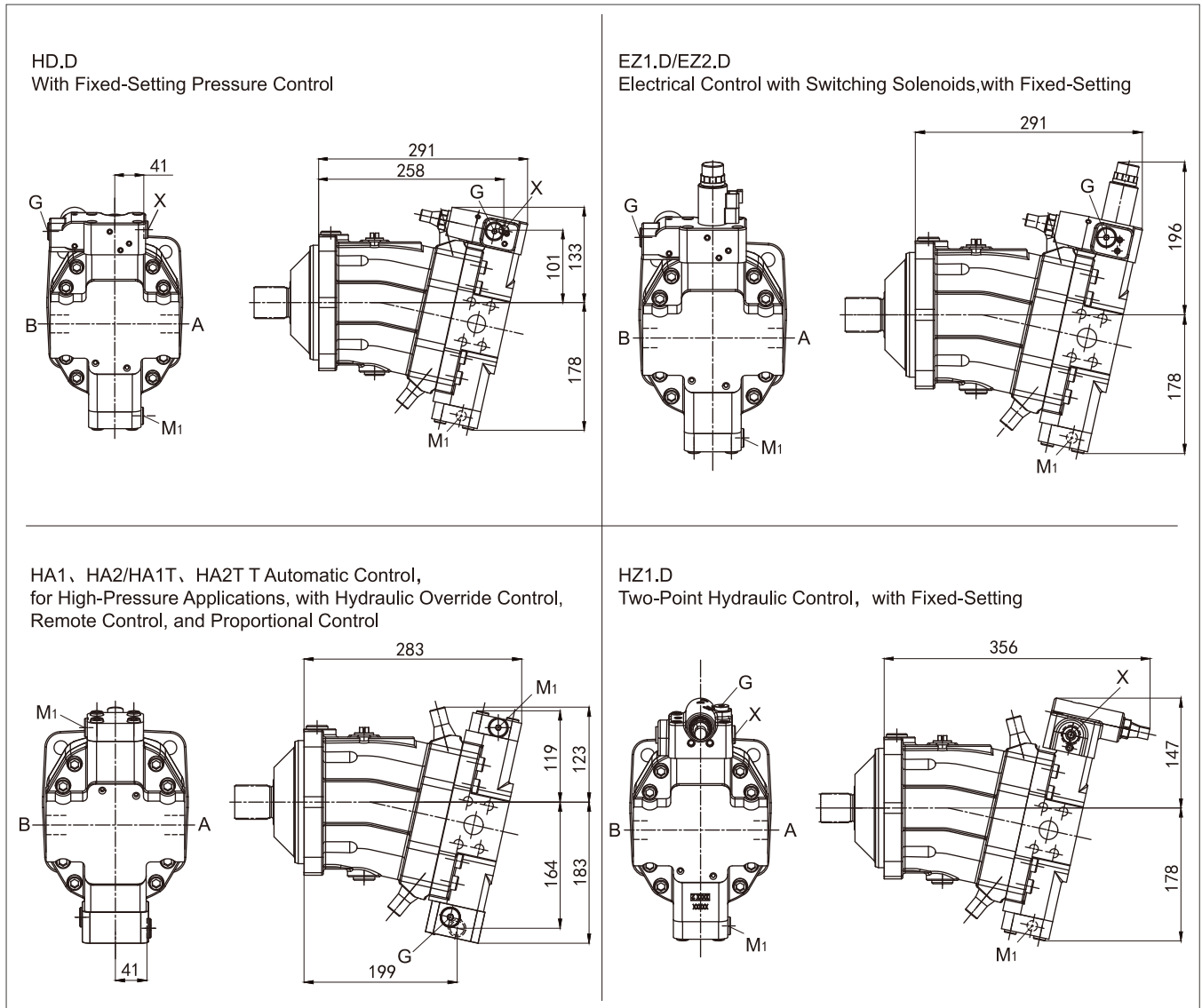



► Installation Dimensions, Size 160/170

EP.D electrical proportional control, with Fixed-Setting Pressure Control
SAE flange ports A/B at side, opposite(02)

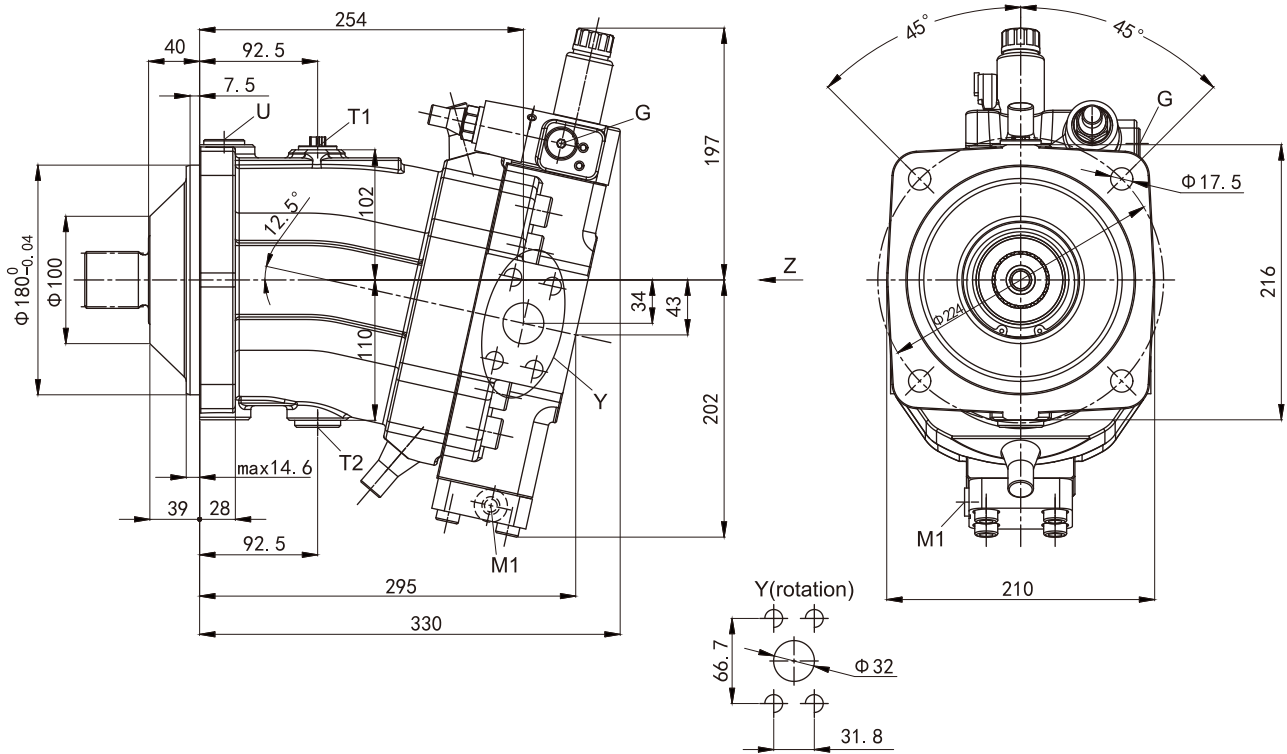

Ports	Usage	Standard	Specifications ¹⁾	Max.pressure ²⁾	State ⁶⁾
A/B	Working port	SAE J518 ³⁾	1 1/4"	450	○
	Fastening thread A/B	DIN 13	M14×2; 19deep		
T1	Case drain port	DIN 3852 ⁵⁾	M26×1.5; 16deep	3	○ ⁴⁾
T2	Case drain port	DIN 3852 ⁵⁾	M26×1.5; 16deep	3	× ⁴⁾
G	Synchronous Contro	DIN 3852 ⁵⁾	M14×1.5; 12deep	450	×
U	Flushing port	DIN 3852 ⁵⁾	M22×1.5; 14deep	3	×
X	Pilot signal(HD、HZ、HA1T/HA2T)	DIN 3852 ⁵⁾	M14×1.5; 12deep	100	○
M1	Control pressure measurement	DIN 3852 ⁵⁾	M14×1.5; 12deep	450	×

- 1): Regarding maximum tightening torque, refer to the safety instructions.
- 2): Depending on the application, instantaneous pressure peaks may occur.
This must be considered when selecting measuring equipment and accessories.
- 3): Dimensions are exclusively according to SAE J518. Metric fastening threads deviate from standard threads.
- 4): Depending on the mounting position, port T1 or T2 must be connected (see also installation instructions).
- 5): Counterbores may be deeper than specified in the relevant standard.
- 6): O=Needs to be connected (comes plugged) X=Plugged (in normal operation)



► Installation Dimensions, Size 160/170

Detail Z

SAE flange ports A/B at side,
opposite(02)

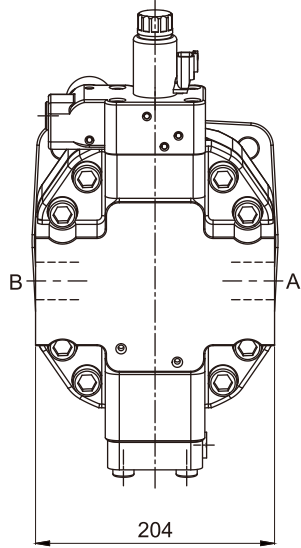

SAE flange ports A/B at rear,
opposite(01)

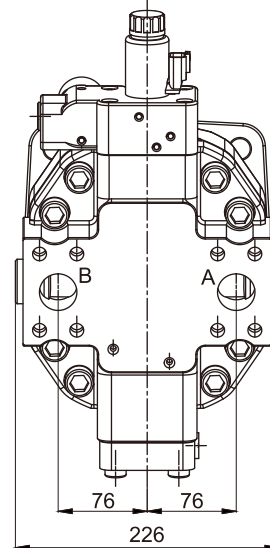

Splined shaft DIN 5480

A-W50×2×30×24×9g

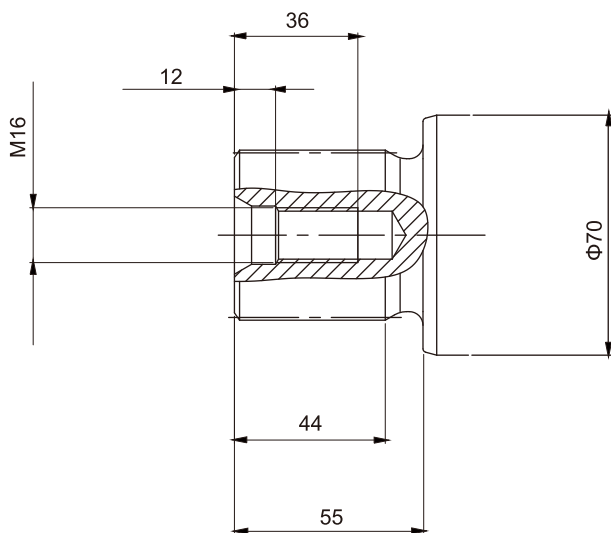

Splined shaft DIN 5480

Z-W45×2×30×21×9g

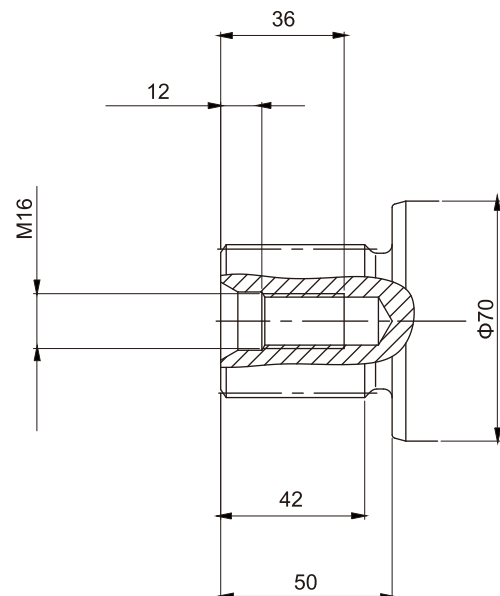



➤ Installation Dimensions, Size 160/170

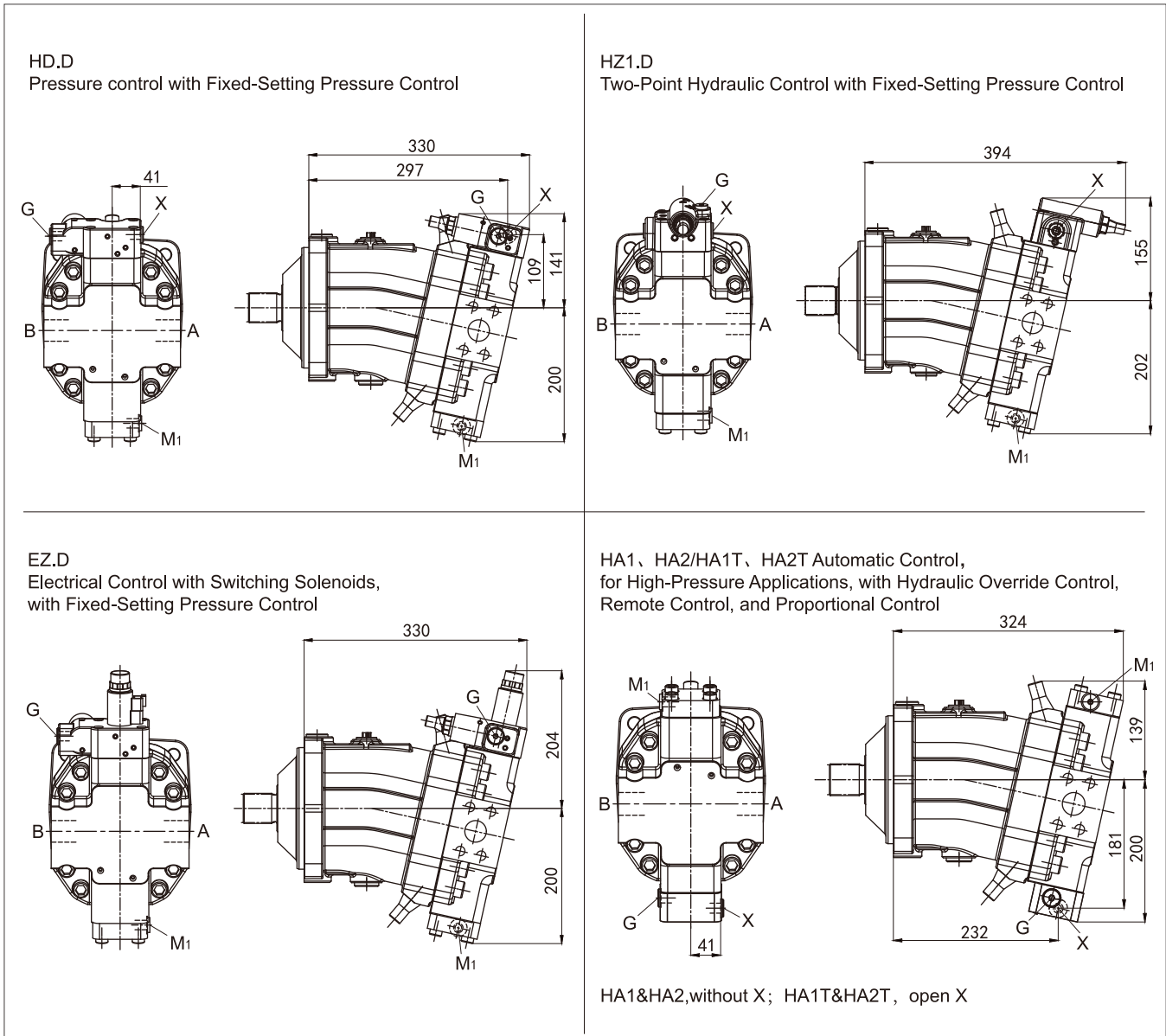



► Installation Dimensions, Size 200

EP.D electrical proportional control, with Fixed-Setting Pressure Control
 SAE flange ports A/B at side, opposite(O2)

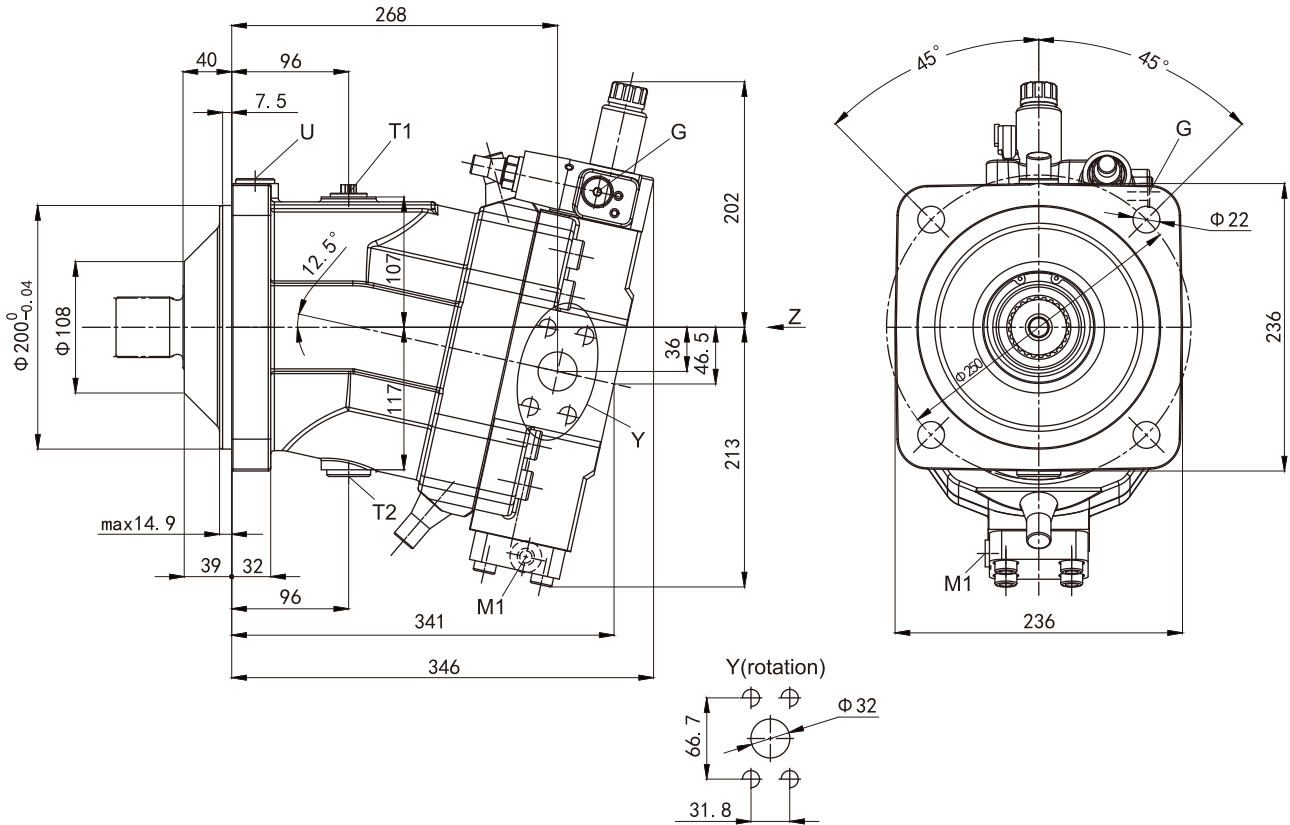

Ports	Usage	Standard	Specifications ¹⁾	Max.pressure ²⁾	State ⁶⁾
A/B	Working port	SAE J518 ³⁾	1 1/4"	450	○
	Fastening thread A/B	DIN 13	M14×2; 19deep		
T1	Case drain port	DIN 3852 ⁵⁾	M26×1.5; 16deep	3	○ ⁴⁾
T2	Case drain port	DIN 3852 ⁵⁾	M26×1.5; 16deep	3	× ⁴⁾
G	Synchronous Contro	DIN 3852 ⁵⁾	M14×1.5; 12deep	450	×
U	Flushing port	DIN 3852 ⁵⁾	M22×1.5; 14deep	3	×
X	Pilot signal(HD、HZ、HA1T/HA2T)	DIN 3852 ⁵⁾	M14×1.5; 12deep	100	○
M1	Control pressure measurement	DIN 3852 ⁵⁾	M14×1.5; 12deep	450	×

- 1): Regarding maximum tightening torque, refer to the safety instructions.
- 2): Depending on the application, instantaneous pressure peaks may occur.
This must be considered when selecting measuring equipment and accessories.
- 3): Dimensions are exclusively according to SAE J518. Metric fastening threads deviate from standard threads.
- 4): Depending on the mounting position, port T1 or T2 must be connected (see also installation instructions).
- 5): Counterbores may be deeper than specified in the relevant standard.
- 6): O=Needs to be connected (comes plugged) X=Plugged (in normal operation)



► Installation Dimensions, Size 200

Detail Z

SAE flange ports A/B at side,
opposite(02)

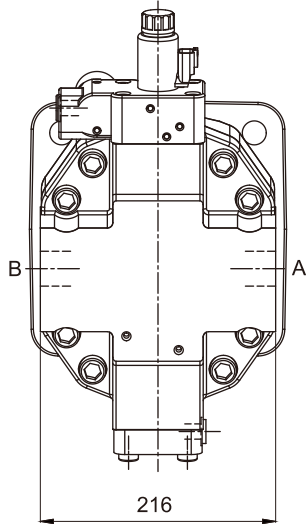

SAE flange ports A/B at rear,
opposite(01)

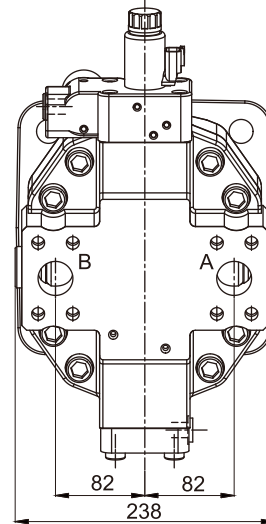

Splined shaft DIN 5480

A-W50×2×30×24×9g

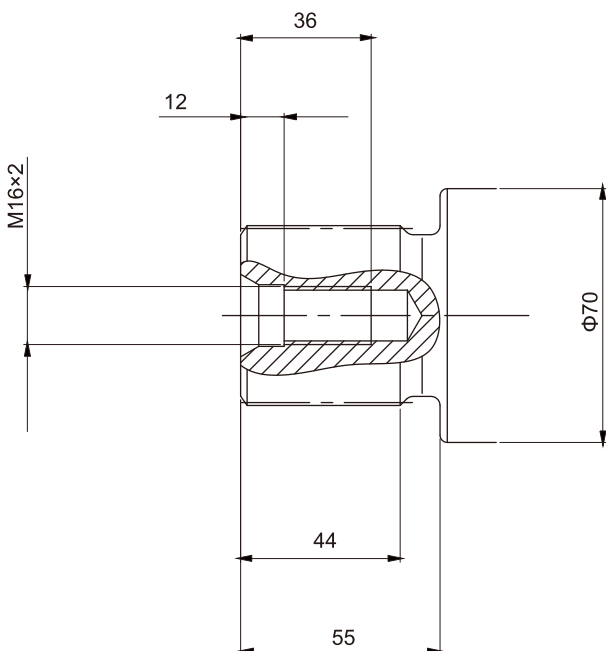



► Installation Dimensions, Size 200

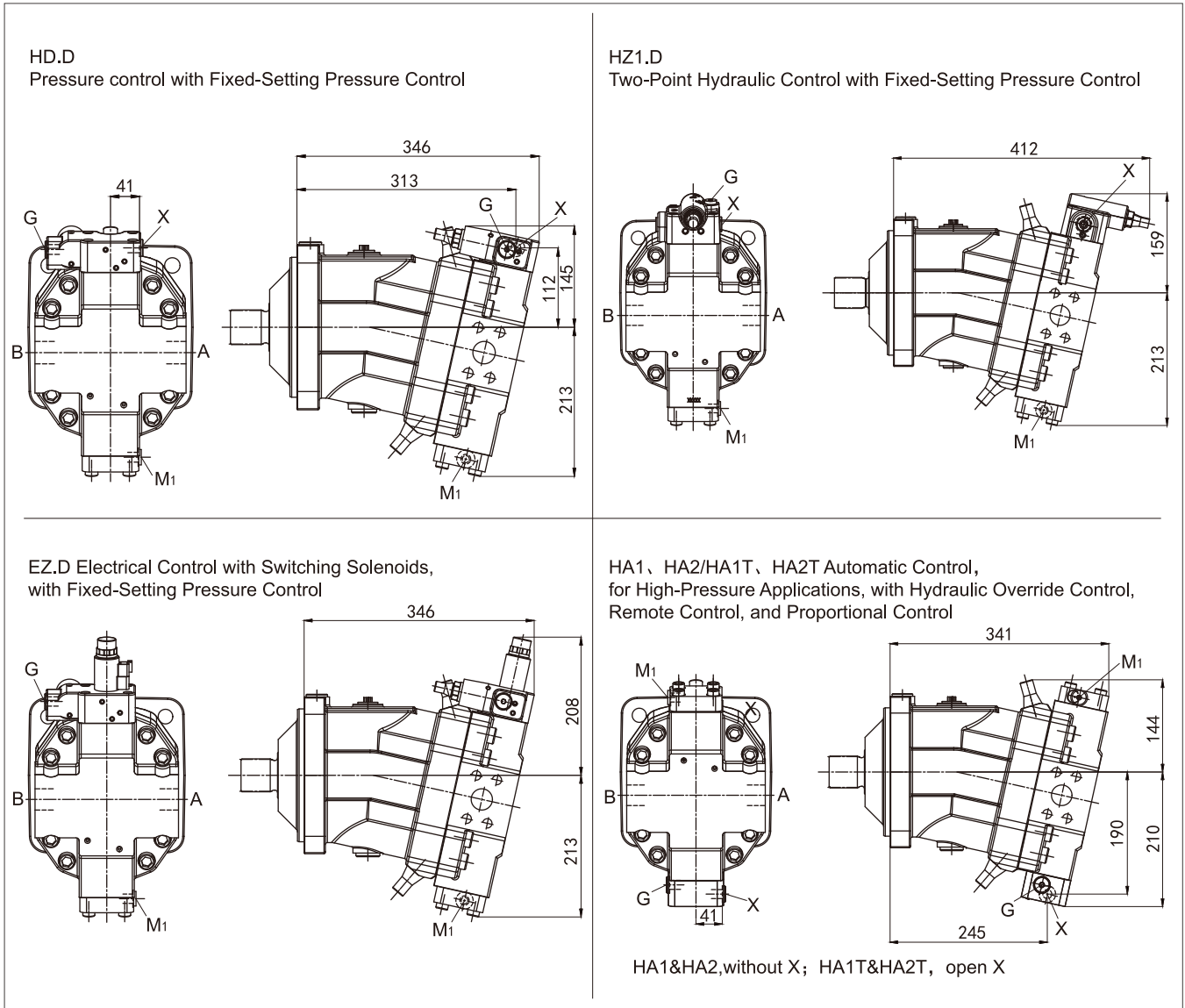



Flushing and Boost-pressure Valve

Flushing and Boost-pressure Valves are used to prevent circuit overheating. In open-loop circuits, these valves solely flush the case from the return line.

In closed-loop circuits, they additionally ensure minimum make-up pressure alongside case flushing.

Hydraulic oil from the low-pressure side of the circuit flows into the motor casing through the flushing valve and drains to the tank via the casing drain port. Oil discharged from the closed-loop circuit must be replaced with cooled hydraulic oil supplied by the charge pump.

The valves are either mounted externally on the port adapter plate or integrated internally (depending on the control model and displacement).

Cracking pressure of the holding valve (Please note when setting the primary valve).

Fixed setting _____ 1.6MPa

Flushing valve spool shift pressure Δp _____ 0.8 ± 0.1 MPa

Standard flow rate(referenced at low-pressure $\Delta p_{LP}=2.5$ MPa)

Size	Flow
28/55	3.5L/min
80	5L/min
107/115/130	8L/min
160/170	10L/min
200	10L/min

Hydraulic control circuit diagram

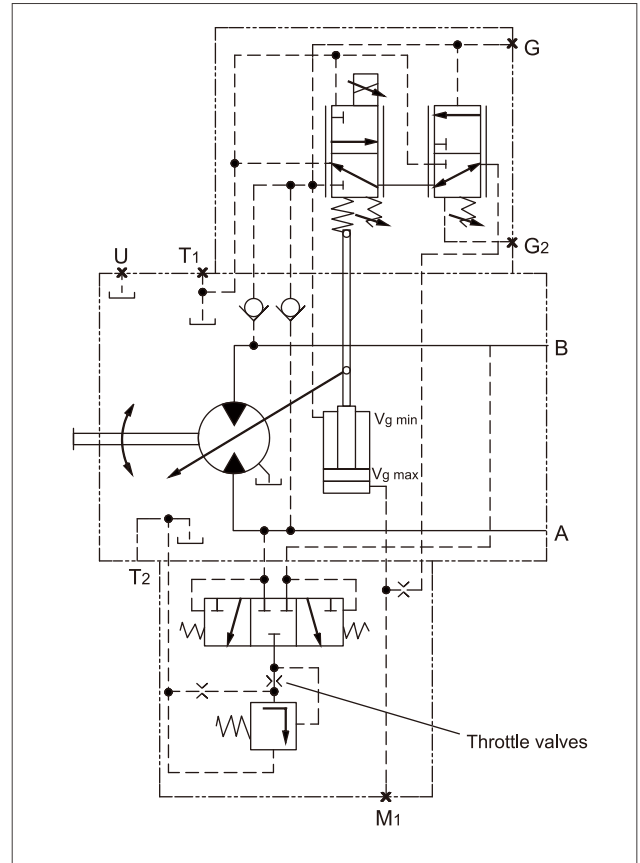

Throttle valves are available with flow rates ranging from 3.5-10L/min.

For non-standard flow requirements, specify throttle valve details when ordering.

Unrestricted flow (without throttle valve) at low-pressure $\Delta p_{LP}=2.5$ MPa is approximately 12 to 14L.

Installation Dimensions

The diagram shows the installation dimensions for three motor models: HA1/HA2, HD/EP/EZ1/EZ2, and EZ3/EZ4. Dimensions A1, A2, A3, and A4 are indicated for each model.

Size	A1	A2	A3	A4
28	214	125	161	-
55	243	133	176	236
80	273	142	193	254
107/115/130	288	144	200	-
160/170	328	154	220	-
200	345	160	231	-



➤ BVD and BVE counterbalance valve

Function

Counterbalance valves for travel drives and winches should reduce the danger of overspeed and cavitation of axial piston motors in open circuits. Cavitation occurs if, during braking, when going downhill or during the load-lowering process, the motor speed is greater than it should be for the given inlet flow and thus the supply pressure falls sharply. If the inlet pressure decreases, the counterbalance valve spool will throttle the return flow and brake the motor until inlet pressure recovers to approximately 2MPa.

Notice

- BVD available for sizes 55 to 200
 - BVE available for sizes 107 to 160
 - The counterbalance valve must be ordered additionally.
- We recommend ordering the counterbalance valve and the motor as a set

Order example:

HA6VM107HA1/63W-VZB378A+HBVD25W38L/41B-V07K00D0800S00A

- For safety reasons, controls with beginning of control at $V_g \text{ min}$ (e.g. HA) are not permissible for lifting winch drives!
- The counterbalance valve does not replace the mechanical service brake and holding brake.

- For the design of the brake release valve, we must know the following data for the mechanical holding brake:

- the cracking pressure
- the volume of the brake spool between minimum stroke (brake closed) and maximum stroke (brake released with 21 bar)
- the required closing time for a warm device (oil viscosity approx. $15 \text{ mm}^2/\text{s}$)

Counterbalance valve for travel drives BVD...F

Application option

- Travel drive for wheeled excavators

Model Example:

HA6VM107HA1/63W-VZB378A+HBVD20F28S/41A-V51R20D0202S00

Counterbalance valve for winches and track drive BVD...W and BVE

Application option

- Winch drives in cranes (BVD and BVE)
- Track drive in excavator crawlers (BVD)

➤ Hydraulic control circuit diagram

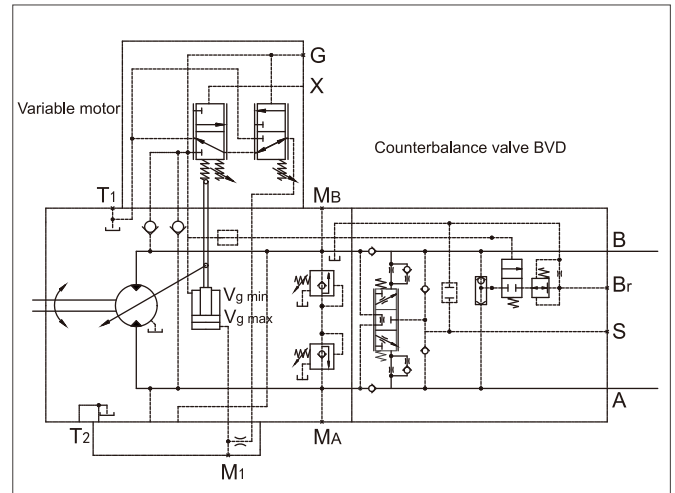

Permissible inlet flow or pressure when using pressure relief valve and BVD/BVE

Motor	Without valve		Limited values when using DBV and BVD/BVE								
			DBV				BVD/BVE				
	p_{nom}/p_{max} (MPa)	$q_v \text{ max}$ (L/min)	NG	p_{nom}/p_{max} (MPa)	$q_v \text{ max}$ (L/min)	Code	NG	p_{nom}/p_{max} (MPa)	$q_v \text{ max}$ (L/min)	Code	
55	40/45	244	22	35/42	240	380	20	35/42	220	388	
80		312									32
107		380	BVD/BVE								
107		380			320						
160		496									
200	580	Supply according to requirements									

- DBV _____ Relief valve
- BVD _____ Counterbalance valve, double-acting
- BVE _____ Counterbalance valve, one-sided



➤ Installation Dimensions—counterbalance valve

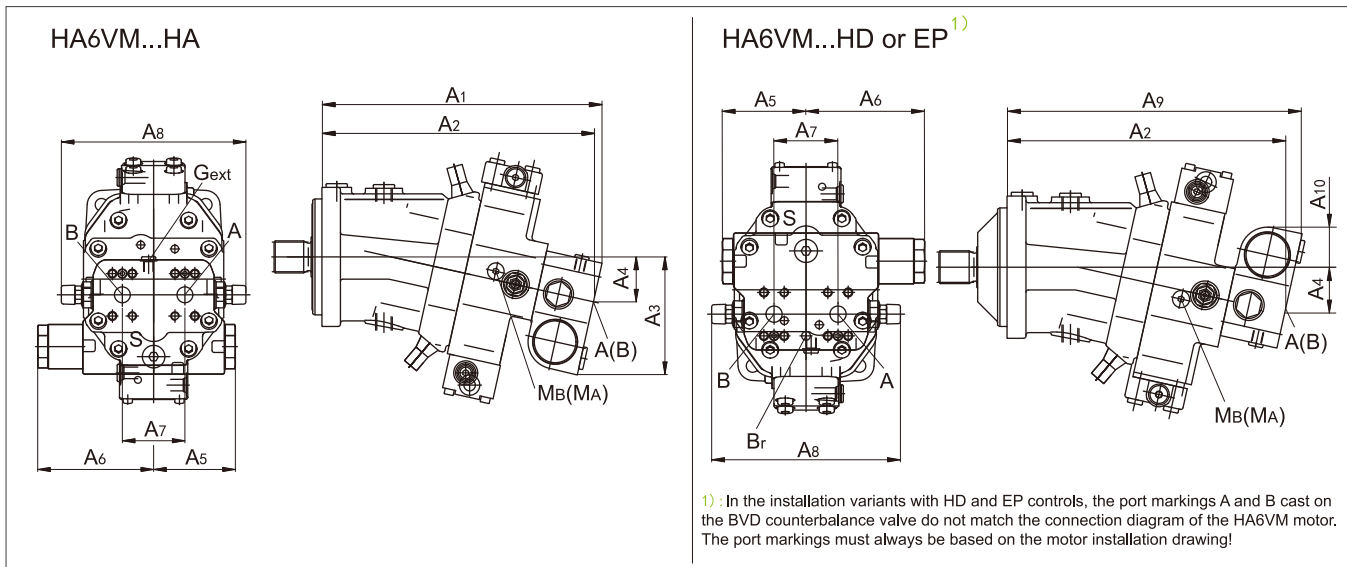

Size	Counterbalance valve Type	Ports A/B	A1	A2	A3	A4	A5	A6	A7	A8	A9	A10
55. . . 38	BVD20...17	3/4"	311	302	143	50	98	139	75	222	326	50
80. . . 38	BVD20...27	1"	340	331	148	55	98	139	75	222	355	46
107/115/130. . . 37	BVD20...28	1"	362	353	152	59	98	139	84	234	377	41
107/115/130. . . 38	BVD25...38	1 1/4"	380	370	165	63	120.5	175	84	238	395	56
160/170. . . 38	BVD25...38	1 1/4"	417	407	170	68	120.5	175	84	238	432	51
200/215. . . 38	BVD25...38	1 1/4"	448	438	176	74	120.5	175	84	299	463	46
107/115/130. . . 38	BVE25...38	1 1/4"	380	370	171	63	137	214	84	238	397	63
160/170. . . 38	BVD25...38	1 1/4"	417	407	176	68	137	214	84	238	432	59
200. . . 38	BVE25...38	1 1/4"	448	438	182	74	137	214	84	299	463	52

Ports		Version	HA6VMplate	Standard	Size ¹⁾	Max. pressure ²⁾ (MPa)	State ⁴⁾
A/B	Working line			SAE J518	see table above	42	O
S	Boost port	BVD 20		DIN 3852 ³⁾	M22x1.5, 14deep	3	X
		BVD 25/BVE 25		DIN 3852 ³⁾	M27x2, 16deep	3	X
Br	Brake release port, reduced high pressure	L	7	DIN 3852 ³⁾	M12x1.5, 12.5deep	3	O
			8	DIN 3852 ³⁾	M12x1.5, 12deep	3	O
Gext	Brake release port, high pressure	S		DIN 3852 ³⁾	M12x1.5, 12.5deep	42	X
MA/MB	Measuring port, pressure A, B			ISO 6149 ³⁾	M18x1.5, 14.5deep	42	X
O=Needs to be connected (comes plugged), X=Plugged (in normal operation)							

- 1): For information on tightening torques, see the instruction manual
- 2): Momentary pressure peaks can occur depending on application. Keep this in mind when selecting measuring devices and fittings.
- 3): The countersink may be deeper than specified in the standard.
- 4): O=Needs to be connected (comes plugged) X=Plugged (in normal operation)



► Installation Dimensions-counterbalance valve

Upon delivery, the counterbalance valve is mounted to the motor with two set screws (shipping protection). During hydraulic line installation, these set screws must not be removed. If the counterbalance valve and motor are delivered separately, the valve must first be installed on the motor's port adapter plate using the provided set screws.

The counterbalance valve is ultimately secured to the motor's SAE flange using the following screws:

6 screws (1, 2, 3, 4, 5, 8) length B1+B2+B3

2 screws (6, 7) length B3+B4

Tighten screws 1 to 8 in the specified sequence in two stages as shown in the figure below:

Step 1: Tighten screws to half the tightening torque,

Step 2: Tighten screws to maximum tightening torque.

Torque table

Thread	Strength	Torque(Nm)
M6x1(Screws)	10.9	15.5
M10	10.9	75
M12	10.9	130
M14	10.9	205

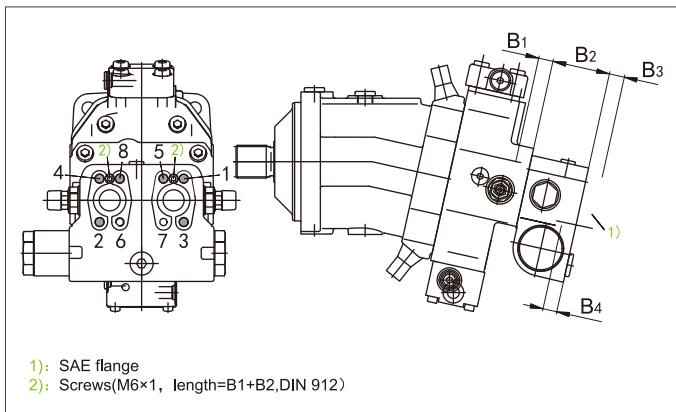

Size	55...38	80...38, 107...37	107/160/200...38
B1	M10x1.5,17deep	M12x1.75,15deep	M14x2,19deep
B2	68	68	85
B3	For specific users		
B4	M10x1.5,15deep	M12x1.75,16deep	M14x2,19deep



➤ Speed sensor

“F” for speed sensor

HA6VM...F(“for speed sensor”, without sensor)is equipped with a spline on the rotary group.

A signal proportional to motor speed can be generated with the mounted speed sensor.

This signal is detected by the sensor and sent to the computing unit.

F is designed for installation on HDD Hall-effect speed sensors. The HDD sensor is mounted on a flat surface using two set screws.

➤ Hydraulic control circuit diagram

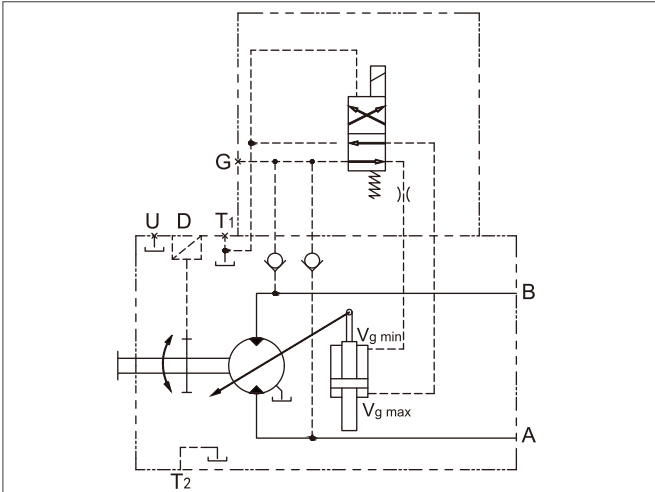

➤ Dimensions

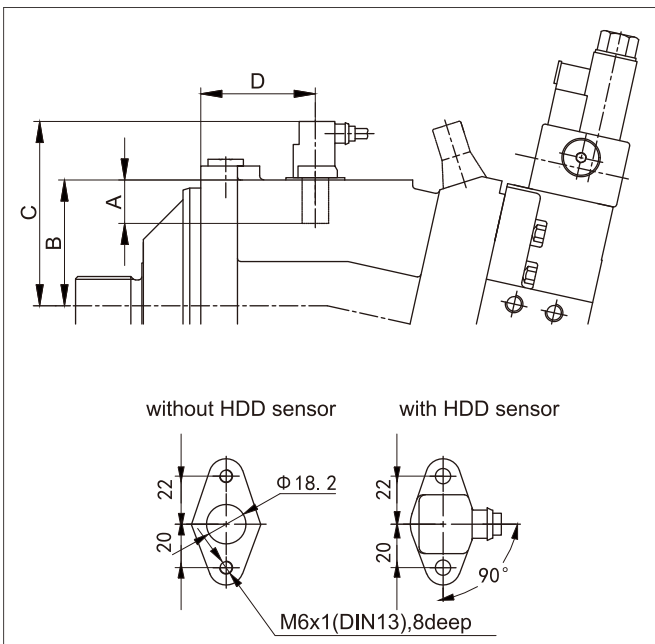

Size		28	55	80	107/115	160/170	200		
Number of teeth		40	54	58	67	75	80		
HDD	A	Insertion depth ±0.1		16	16	16	16		
	B	Contact surface		60	72.6	76.6	85.6	93.6	98.6
	C		98	111	115	124	132	137	
	D		58	67	76	78	92.5	96	



Speed sensor

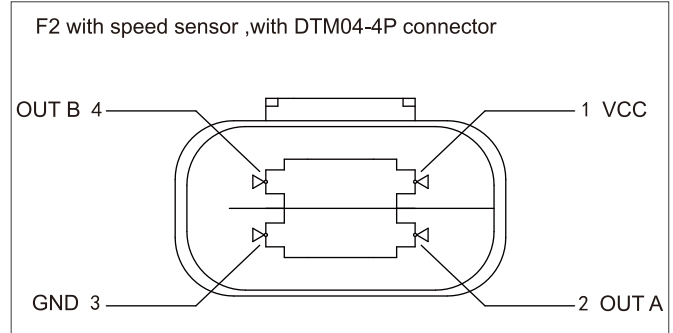
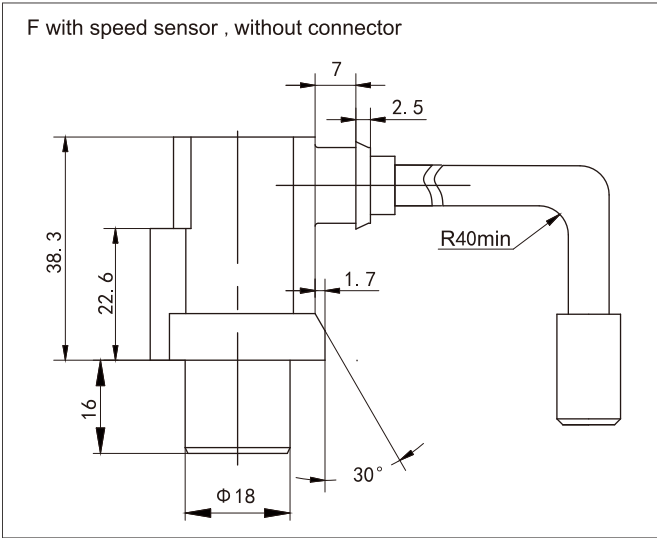

DTM04-4P Terminals		
Terminals	Terminal wire colors	Link
1	Brown VCC	Power supply
2	White OUT A	Speed signal A
3	Blue GND	Ground
4	Black OUT B	Speed signal B

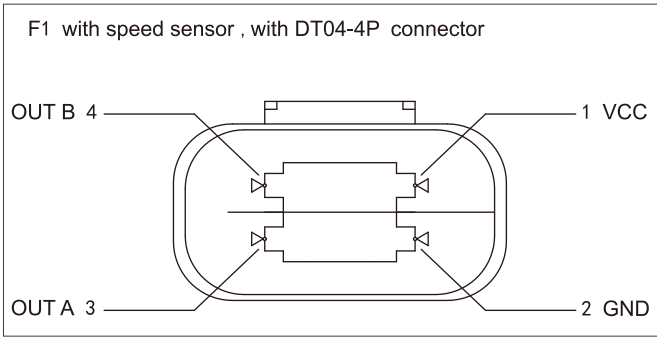

DT04-4P Terminals		
Terminals	Terminal wire colors	Link
1	Brown VCC	Power supply
2	Blue GND	Ground
3	Black OUT A	Speed signal (Uf1)
4	Black OUT B	Speed signal (Uf2)

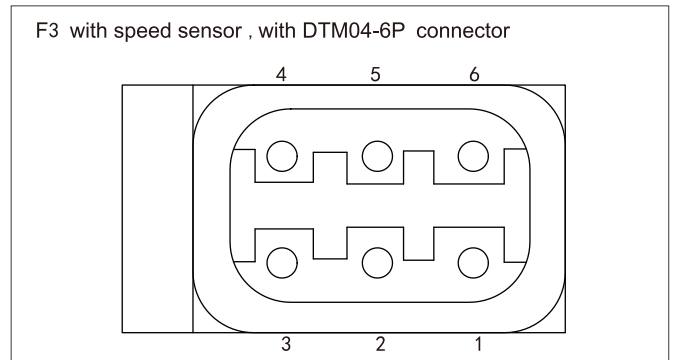

DTM04-6P Terminals	
1	Speed signal 2
2	Direction signal
3	Speed signal 1
4	Power supply
5	Ground
6	Temperature



Installation instructions

General

The axial piston unit must be filled with hydraulic fluid and air bled during commissioning or operation. This must also be observed following a longer standstill as the system may leak via the hydraulic lines.

The leakage in the housing must be directed to the reservoir via the highest drain port. Under all working conditions, the suction line and the case drain line must flow into the reservoir below the minimum fluid level.

Below-reservoir installation (standard)

The motor is installed below the minimum fluid level of the reservoir.

Recommended installation positions: ① and ②.

Above-reservoir installation

The motor is installed above the minimum fluid level of the reservoir. Note: installation position (shaft upwards)

In this installation position, the hydraulic fluid leaks partially in the housing and the bearings are not sufficiently lubricated.

Hence, a check valve (cracking pressure: 0,05 MPa) should be installed in the case drain line to prevent draining of system via the drain line.

Installation positions

See examples in the figure below. Other installation positions are available upon request.

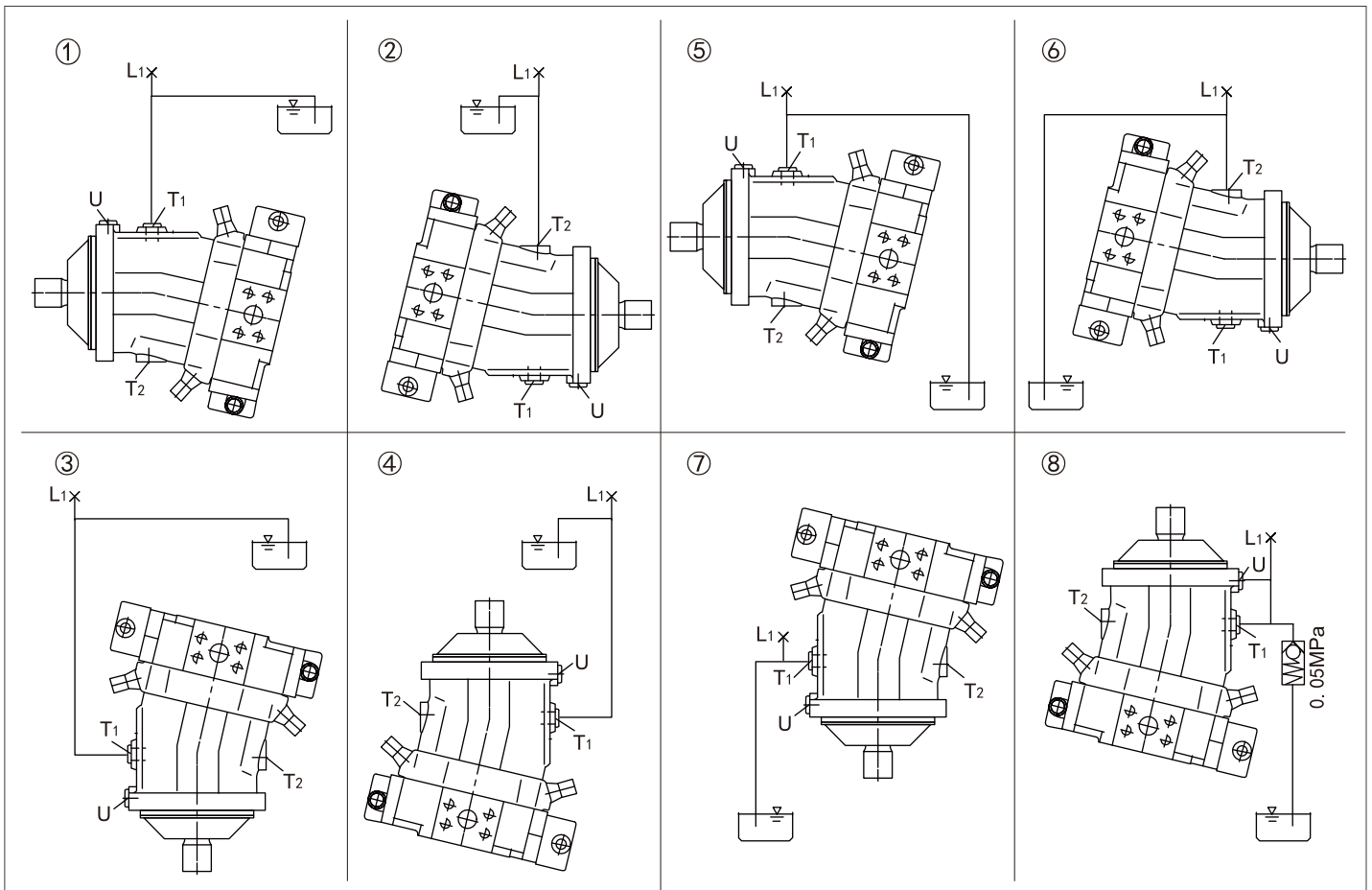

Installation Position	Air Bleed	Filling Port
①	-	T1 (L1)
②	-	T2 (L1)
③	-	T1 (L1)
④	U	T1 (L1)

Installation Position	Air Bleed	Filling Port
⑤	U (L1)	T1 (L1)
⑥	L1	T2 (L1)
⑦	L1	T1 (L1)
⑧	U	T1 (L1)



> Installation instructions

- The motor HA6VM is designed to be used in open and closed circuits.
- The project planning, installation and commissioning of the axial piston unit require the involvement of qualified skilled persons.
- During and shortly after operation, there is a risk of getting burnt on the axial piston unit and especially on the solenoids. Take the appropriate safety measures (e.g. by wearing protective clothing).
- Depending on the operating conditions of the axial piston unit (working pressure, fluid temperature), the characteristic curve may shift.

— Working ports:

The ports and fastening threads are designed for the specified maximum pressure. The machine or system manufacturer must ensure the connecting elements and lines correspond to the specified application conditions (pressure, flow, hydraulic fluid, temperature) with the necessary safety factors.

The working ports and function ports are only intended to accommodate hydraulic lines.

- Compliance with all contained data and instructions is mandatory.
- Not all versions of the product are approved for use in safety functions according to ISO 13849.

— Apply the following tightening torques:

Mounting Bolts:

For mounting bolts with ISO metric threads (per DIN 13) or ASME B1.1 standard threads, tightening torques should be individually verified according to VDI 2230 specifications.

Threaded Holes in Axial Piston Units:

The maximum permissible tightening torque $M_{G \max}$ represents the absolute limit for threaded holes and must not be exceeded. Refer to the table below for specific values.

Locking Screws:

For factory-supplied metal locking screws, apply the specified tightening torque M_v . Refer to the table below for values.

Port standard	Thread size	Maximum permissible tightening torque for internal threaded holes $M_{G \max}(\text{Nm})$	Required tightening torque for set screws $M_v(\text{Nm})^{1)}$	Specifications for Hex Socket Set Screws (mm)
DIN 3852	M12×1.5	50	25 ²⁾	6
	M14×1.5	80	35	6
	M16×1.5	100	50	8
	M18×1.5	140	60	8
	M22×1.5	210	80	10
	M26×1.5	230	120	12
	M27×2	330	135	12
	M33×2	540	225	17
	M42×2	720	360	22

1) The tightening torque applies to screws that are "dry" as received upon delivery and to screws that are "slightly lubricated" during installation.

2) In the "slightly lubricated" condition, for M12×1.5, the tightening torque M_v is reduced to 17 Nm.



Since 2002

Over twenty years of deep cultivation in the field of hydraulic Solutions

HYTEK is a high technology enterprise integrating R&D, production, sales and service of hydraulic power products. Provides professional hydraulic transmission control products and solutions for construction machinery, road machinery, material handling machinery, agricultural and forestry machinery, industrial equipment and other fields. After more than 20 years of continuous R&D, technological innovation, market development and application services, technical level and the scale of production and sales have been on the forefront of the industry. Hytek has been committed to helping the development of subdivided industries with innovative hydraulic technology, "focusing on the challenges and pressures of customers, providing competitive products and solutions, reducing costs and increasing efficiency for customers, and continuously creating maximum value".

Product Series

- Open Circuit Pump
- Closed Circuit Pump
- Fixed Displacement Motor
- Variable Displacement Motor
- Hydrostatic Transmission Unit
- Internal Gear Pump
- Vane Pump
- Proportional valve/
Industrial Hydraulic Valve

For more information,
please visit our official website and social media:en.hytek.cn



@Hytek Power

HYTEK POWER CO.,LTD.

No. 99, Shengyuan Road, Tengqiao Town, Lucheng District, Wenzhou City 325029, Zhejiang, CHINA

Email: globalsales@hytek.cn

America Canada Germany Italy Russia Türkiye Australia South Korea Thailand India Indonesia South Africa

HYTEK-REV1.0 04/2026

If there are any other modifications, no further notice will be given.