



Axial Piston Variable Pump HP4VC Series: 0*

Size: 28/45/53 mL/r
Rated pressure: 30 MPa
Max. pressure: 35 MPa



Features



- Axial piston variable pump in swashplate design for hydrostatic drives in closed circuits
- The flow is proportional to the drive speed and displacement and is infinitely varied
- The output flow increases from zero to the maximum value as the swashplate swivels
- The flow direction changes when the swashplate is moved through the neutral position
- Various mutually compatible control options to provide diverse control and regulation functions
- Two pressure relief valves on each high-pressure side to prevent overload of hydrostatic drives (pump and motor)
- Pressure relief valve with boost function
- Integrated boost pump works as the boost and control pump
- Maximum boost pressure limited by integrated boost-pressure relief valve
- With integrated power cut-off valve as standard

Contents



● Model Code.	02
● Structure.	05
● Hydraulic Circuit Diagram	05
● Technical Data.	07
● HD Pilot Pressure Control.	08
● HW Mechanical Servo Control.	09
● EP Electric Control with Proportional Solenoid.	11
● EZ Electric Control with Switching Solenoid.	12
● High Pressure Relief Valves.	13
● Installation Dimensions,28.	14
● Installation Dimensions,45/53.	18
● Filtration.	22
● Installation instructions.	24



> Model Code

	c	A	B	C	D	E	F	G	H	I	K	M	N	P	R	S	T	U	X	Z
HP4V	C								/	0*		-		C						-

Axial Piston Unit

-	Swashplate design, variable closed circuits	HP4V
---	---	------

Operation

c		28	45	53	
	Closed circuit	●	●	●	C

Displacement

A	Geometric displacement, in mL/r	28	45	53	
---	---------------------------------	----	----	----	--

Variable Control Method

B	Hydraulic control	Pilot pressure control	Without inlet filtration		○	●	●	HD1
			With inlet filtration	●	●	●	HD3	
		Mechanical servo		●	●	●	HW	
	Electric control	With proportional solenoid	Without inlet filtration	U=12V DC	●	●	●	EP1
				U=24V DC	●	●	●	EP2
			With inlet filtration	U=12V DC	●	●	●	EP3
				U=24V DC	●	●	●	EP4
		With switching solenoid	Without inlet filtration	U=12V DC	○	●	●	EZ1
				U=24V DC	○	●	●	EZ2
	With inlet filtration		U=12V DC	○	○	○	EZ3	
			U=24V DC	○	○	○	EZ4	

Brake Valve

C	Without brake valve (without code)			28	45	53	
	only for HW control valve on the HW valve body	NO	U=12V DC	○	●	●	O1
			U=24V DC	●	●	●	O2
		NC	U=12V DC	○	○	○	C1
			U=24V DC	○	●	●	C2
	all control valve on the back cover	NO	U=12V DC	—	—	—	O3
			U=24V DC	—	—	—	O4
		NC	U=12V DC	—	—	—	C3
			U=24V DC	—	—	—	C4

Neutral Position Switch(only for HW control)

D	Without neutral position switch (without code)			28	45	53	
	With neutral position switch (with DEUTSCH molded connector)			●	○	●	L



> Model Code

	c	A	B	C	D	E	F	G	H	I	K	M	N	P	R	S	T	U	X	Z	
HP4V	C								/	0*		-		C						-	

Pressure Cutoff Valve

E		28	45	53	
	Without pressure cut-off valve (without code)	●	●	●	
	With pressure cut-off valve(standard)	●	●	●	D

Stroke Limiter

F		28	45	53	
	Without mechanical stroke limiter (without code)	●	●	●	
	With mechanical stroke limiter, externally adjustable	○	●	●	M

Stroking Chamber Pressure Port(X3/X4)

G		28	45	53	
	Without port X3/X4 (without code)	●	●	●	
	With port X3/X4	—	—	—	T

DA Control Valve

H		28	45	53	
	Without DA control valve	●	●	●	1
	With DA control valve	—	—	—	2

Series

I		28	45	53	
	Series 0*	●	●	●	0*

Direction of Rotation (viewed on drive shaft)

K		28	45	53	
	CW (right-hand)	●	●	●	R
	CCW (left-hand)	●	●	●	L

Sealing Material

M		28	45	53	
	NBR seal + FKM Shaft seal	●	●	●	N
	NBR seal + NBR Shaft seal	●	●	●	P

Drive Shaft

N	Splined shaft ANSI B92.1-1976		28	45	53	
	1" 15T 16/32DP	For single pump	●	●	●	S
		With connecting flange	○	●	●	L
	1 1/4" 14T 12/24DP	For the 1st pump of a combination pump	○	●	●	T

Mounting Flange

P		28	45	53	
	SAE J744-101-2 (B) (2*Φ15, Φ101.6h8, 9.5)	●	●	●	C



> Model Code

	c	A	B	C	D	E	F	G	H	I	K	M	N	P	R	S	T	U	X	Z	
HP4V	C								/	0*		-			C					-	

Working Ports (viewed on drive shaft)

R	Ports at same side	28	45	53	
	Suction port downwards, working port leftwards	●	●	●	10
	Suction port upwards, working port rightwards	○	○	○	13

Boost Pump and Through Drive

S	Splined shaft ANSI B92.1			28	45	53		
	Integrated boost pump	Without through drive			●	●	●	F00
		Flange SAE J 744-82-2(A)	5/8"	9T 16/32DP	●	●	●	F01
		Flange SAE J 744-101-2(B)	7/8"	13T 16/32DP	● ¹⁾	●	●	F02
			1"	15T 16/32DP	○	●	●	F04
	Without integrated boost pump	Without through drive			●	●	●	N00
		Flange SAE J 744-82-2(A)	5/8"	9T 16/32DP	●	●	●	K01
		Flange SAE J 744-101-2(B)	7/8"	13T 16/32DP	○	●	●	K02
			1"	15T 16/32DP	○	●	●	K04

High Pressure Relief Valve

T	With high-pressure relief valve, direct operated, fixed setting	35-45MPa	Without bypass	—	●	—	2
		25-34MPa	Without bypass	●	●	●	3
		10-24MPa	Without bypass	●	●	●	4
		25-34MPa	With bypass	●	●	●	5
		10-24MPa	With bypass	●	●	●	6
		35-45MPa	With bypass	—	●	—	7

Filtration

U		28	45	53	
	External suction filter (not included in delivery, to be selected by customer)	●	●	●	S
	External pressure filter (not included in delivery, to be selected by customer)	●	●	●	D
	External fluid supply (optional, only for N00, K**)	●	●	●	E

Solenoid Connector

X	Without solenoid (without code)	28	45	53	
	DEUTSCH molded connector, 2-pin, without suppressor diode Connector model: Deutsch DT04-2p (for HWO/HWC/EP/EZ)	●	●	●	P

Special Configuration

Z	Without special configuration (without code)	28	45	53	
	Special configuration	●	●	●	***

¹⁾Splined shaft 7/8" 13T 16/32DP only used for 13.8mL/r Boost pump.

● Available ○ On request — Not available ■ Recommended model



➤ Structure

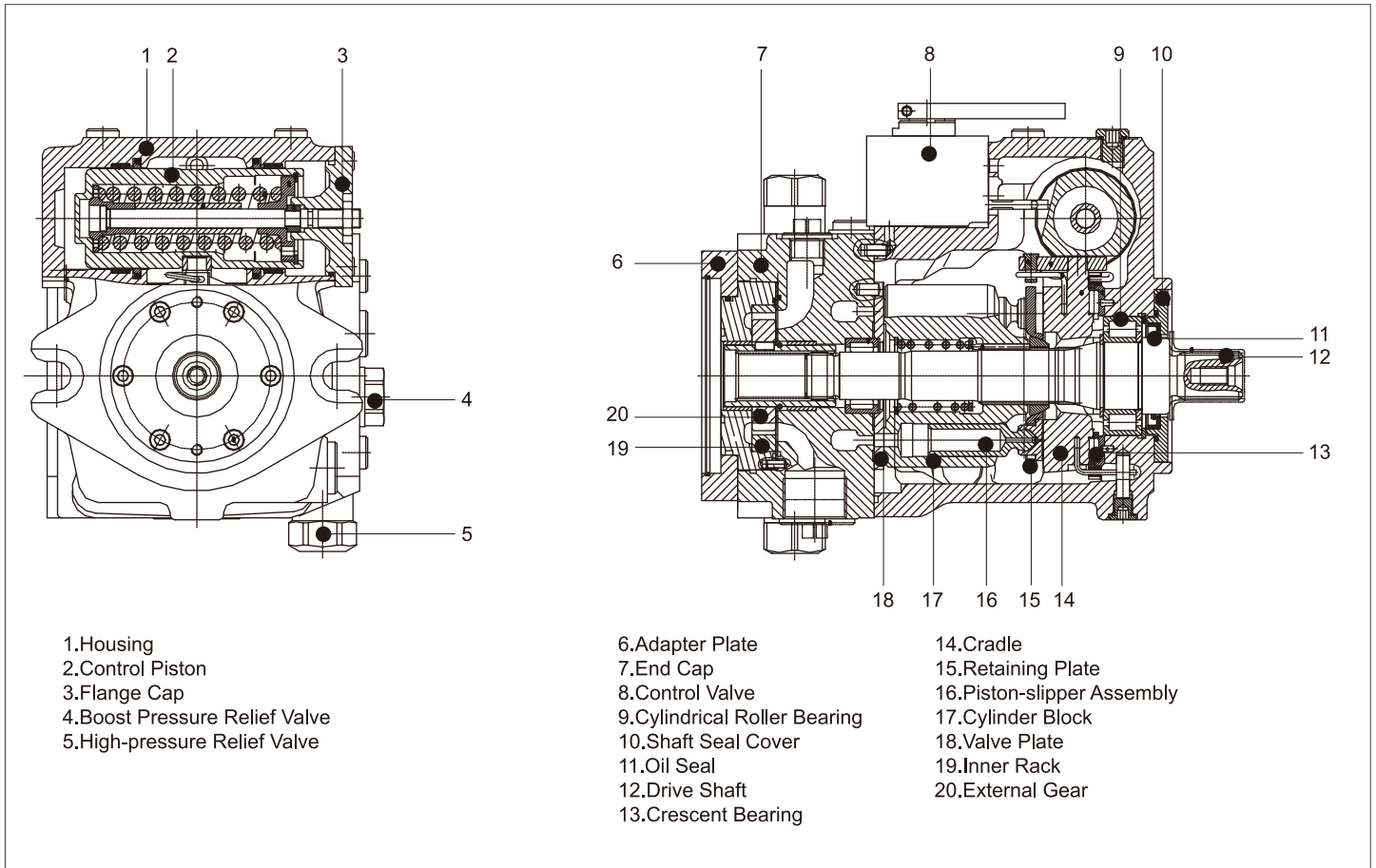

➤ Circuit Diagram

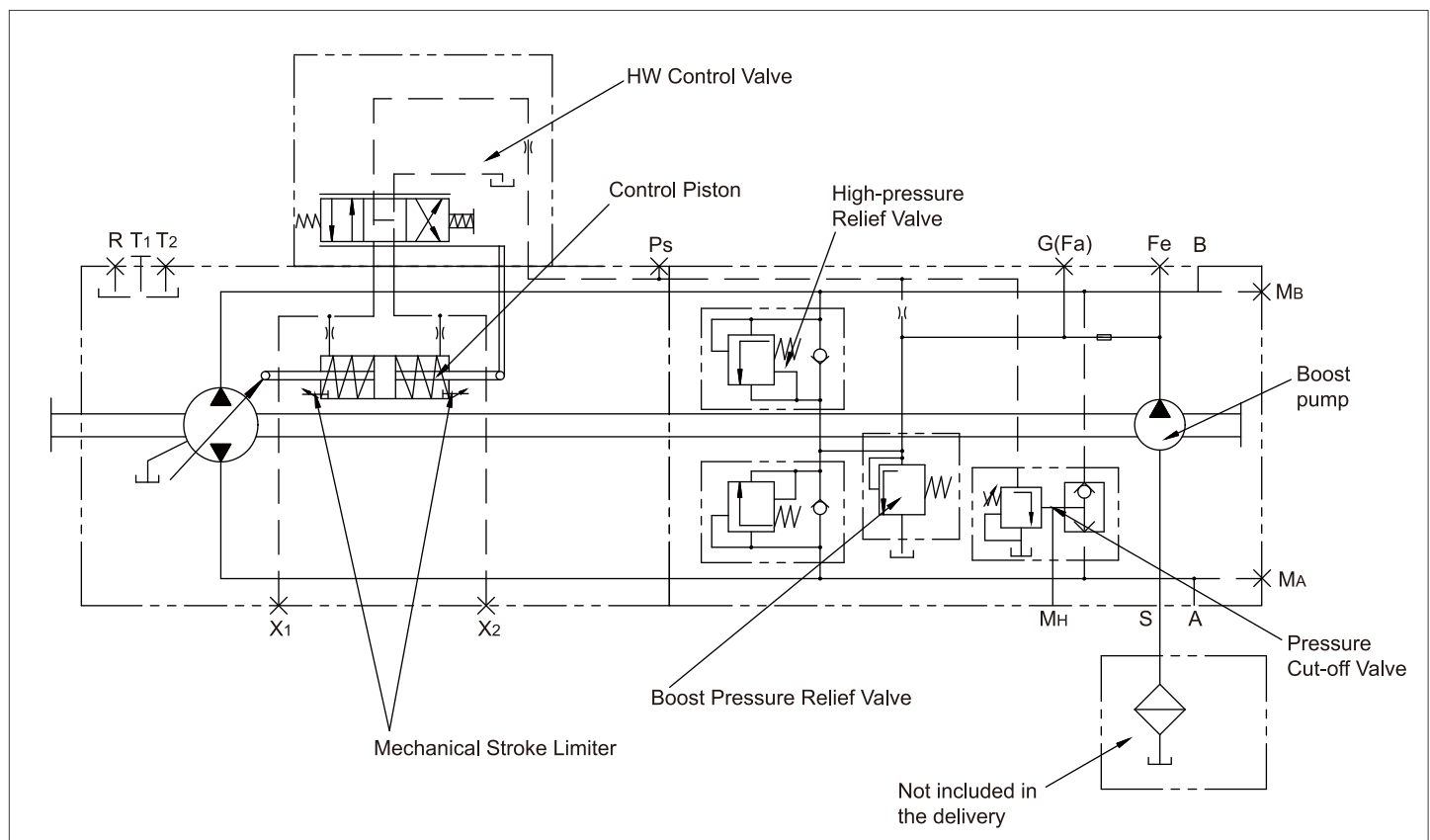



> Hydraulic Fluids

Mineral oil

> Working Viscosity

In order for the optimum efficiency and service life, it is recommended to select the working viscosity at working temperature within the range below:

$$V_{opt} = \text{optimal working viscosity } 16 \dots 36 \text{ mm}^2/\text{s}$$

It is subject to the temperature of a closed circuit.

> Limit Viscosity

Limit viscosity:

$$V_{min} = 5 \text{ mm}^2/\text{s}$$

Short-term operation ($t < 3 \text{ min}$)

Permissible maximum temperature $t_{max} = +115^\circ\text{C}$

$$V_{max} = 1600 \text{ mm}^2/\text{s}$$

Short-term operation ($t < 3 \text{ min}$)

Cold start ($p \leq 3 \text{ Mpa}$, $n \leq 1000 \text{ rpm}$, $t_{min} = -40^\circ\text{C}$)

Only for no-load start, it must reach the optimum working temperature in 15 min.

> Selection Diagram

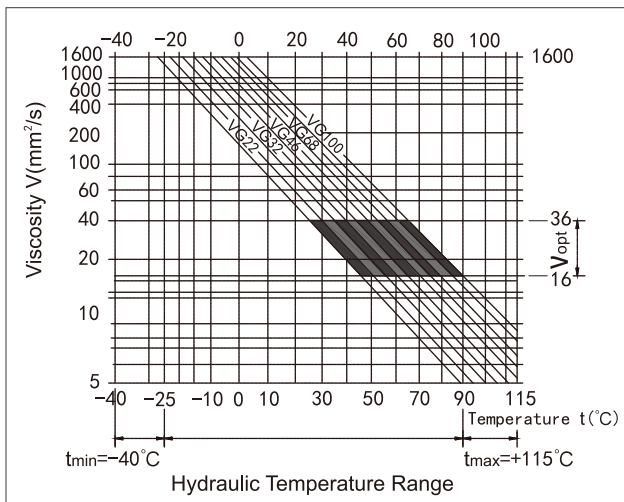

> Instructions on Selection of Hydraulic Fluid

The working temperature dependent on the ambient temperature is required for correct selection of hydraulic fluid. It refers to the circuit temperature of a closed circuit and the reservoir temperature of an open circuit.

The hydraulic fluid should be so selected that the working viscosity in the working range is within the optimum range (V_{opt} , the shaded area on the selection diagram). The higher viscosity is recommended under the same conditions.

For example:

At an ambient temperature of $X^\circ\text{C}$, the working temperature of the circuit is 60°C . The viscosity within the optimum range (V_{opt} , shaded area) is VG46 or VG68 and the latter should be selected.

Note:

The case drain temperature depends on the pressure and speed, and it is always higher than the circuit temperature. The temperature at any point within the system should not exceed $+115^\circ\text{C}$. Please contact us if the above condition cannot be maintained due to extreme working conditions.

> Filtration

Finer filtration improves the cleanliness level of the hydraulic fluid, thus increasing the service life of the axial piston unit. To ensure normal operation of the axial piston unit, a cleanliness level of at least 20/18/15 according to ISO 4406 is to be maintained.

Based on the system and application, we recommend for HP4VC:
filter element $\beta_{20} \geq 100$

β should not decrease as differential pressure of the filter element increases.

When the hydraulic fluid has a high temperature ($+90^\circ\text{C}$ to $+115^\circ\text{C}$), the cleanliness level should at least reach 19/17/14 according to ISO 4406. Please contact us if the above cleanliness level cannot be maintained.

> Working Pressure Range

Input

Variable pump (with external fluid supply, E):

For EP, HW and HD controllers

Boost pressure ($n=2000 \text{ rpm}$) P_{sp} _____ = 1.8 MPa

For DG controller

Boost pressure ($n=2000 \text{ rpm}$) P_{sp} _____ = 2.5 MPa

Boost pump

Suction pressure $P_{s \text{ min}}$ ($V \leq 30 \text{ mm}^2/\text{s}$) _____ $\geq 0.08 \text{ MPa}$

At short-term cold start ($t < 3 \text{ min}$) _____ $\geq 0.05 \text{ MPa}$

Output

Variable pump:

Pressure at port A or B

Rated pressure P_{NX} _____ 35 MPa

Max. pressure P_{max} _____ 40 MPa

Total pressure (A+B) P_{max} _____ 60 MPa

Boost pump

Max. pressure $P_{sp \text{ max}}$ _____ 4 MPa

> Oil Seal

Permissible pressure load

The service life of the shaft seal depends on the pump speed and case drain pressure. It is recommended that the average lasting case drain pressure at working temperature is no greater than 0.3 MPa absolute pressure (as the speed falls, the maximum permissible case drain pressure is 0.6 MPa) and the short-term ($t < 0.1 \text{ s}$) permissible absolute pressure peak may reach 1 MPa.

The service life of the shaft seal decreases with increasing frequency of pressure peaks.

The case pressure must be equal to or greater than the external pressure at the shaft seal.

Temperature range

The FKM shaft seal may be used for case temperatures from -25°C to $+115^\circ\text{C}$.

The NBR shaft seal may be used for case temperatures from -40°C to $+90^\circ\text{C}$.



► Technical Data

Size			Unit	28	45	53
Displacement	Variable pump	$V_{g\ max}$	mL/r	29	45	52
	Boost pump($\Delta p=2MPa$) ¹⁾	$V_{g\ SP}$	mL/r	5.8	8.6	8.6
	Large displacement Boost pump($\Delta p=2MPa$)	$V_{g\ SP}$	mL/r	13.8	13.8	13.8
Speed	Maximum speed at $V_{g\ max}$	$n_{\ max\ cont}$	rpm	3900	3300	3300
	Limit maximum ²⁾	$n_{\ min\ limit}$	rpm	4200	3550	3550
	Intermittent maximum ³⁾	$n_{\ max\ interm}$	rpm	4500	3800	3800
	Minimum	$n_{\ min}$	rpm	500	500	500
Flow	At $n_{\ max\ cont}$ and $V_{g\ max}$	$q_{v\ max}$	L/min	113	149	172
Power ⁴⁾	At $n_{\ max\ cont}$ and $V_{g\ max}$, $\Delta p=30MPa$	$P_{\ max}$	KW	57	75	86
Torque ⁵⁾	At $V_{g\ max}$, $\Delta p=30MPa$	$T_{\ max}$	Nm	139	215	248
	At $V_{g\ max}$, $\Delta p=10MPa$	T	Nm	46	72	83
Moment of inertia of drive shaft		J	Kgm ²	0.0017	0.0033	0.0042
Max. angular acceleration ⁴⁾			rad/s ²	5500	4000	3500
Case volume		V	L	0.64	0.75	0.75
Weight (without through drive)		m	KG	25	27	29

1) Factory default

2) Power at half corner power (e.g. at $V_{g\ max}$ and $P_n/2$)

3) At high-speed no-load operation; at overspeed, $\Delta p = 7-15MPa$ and $V_{g\ max}$; at reverse peak load, $\Delta p < 30MPa$, $t < 0.1s$

4) Without boost pump

5) Only valid for a single pump

► Specification Calculation

Flow $q_v = \frac{V_g \cdot n \cdot \eta_v}{1000}$ [L/min]

V_g = Displacement, mL/r

Δp = Differential pressure, MPa

Torque $T = \frac{V_g \cdot \Delta p}{2 \cdot \pi \cdot \eta_{mh}}$ [Nm]

n = Speed, rpm

η_v = Volumetric efficiency

Power $P = \frac{2 \pi \cdot T \cdot n}{60000} = \frac{q_v \cdot \Delta p}{60 \cdot \eta_t}$ [KW]

η_{mh} = Mechanical-hydraulic efficiency

η_t = Total efficiency



HD - Pilot Pressure Control

Dependent on the difference between the pilot pressure P_{St} (at ports Y1 and Y2) of two control lines, the variable cylinder of the pump obtains control pressure via the HD controller so that the swashplate moves to infinitely adjust the displacement. Each control line corresponds to one flow direction.

HD1: without inlet filter

HD3: with inlet filter (standard)

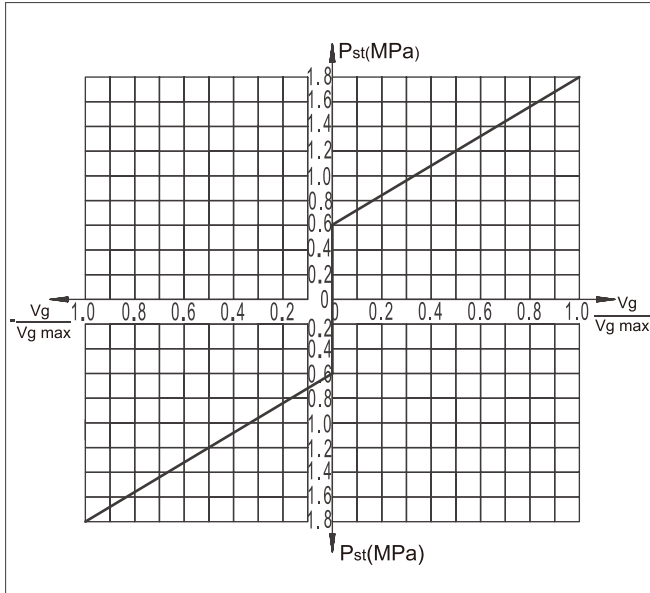

- V_g Displacement at $P_{St}=0.6\text{MPa}$
- $V_{g \text{ max}}$ Displacement at $P_{St}=1.67\text{MPa}$
- Pilot pressure at port Y1 and Y2 $P_{St}=0.6\text{-}1.67\text{MPa}$
- Start of control 0.6MPa
- End of control 1.67MPa (maximum displacement $V_{g \text{ max}}$)

Note:
The HD controller must be unloaded to the neutral position with the external pilot control device on the reservoir.

Thread, control port	
14x1.5-6H	ED seal
9/16-18UNF-2B	ED seal
9/16-18UNF-2B	Corner seal

The spring at the center of the pilot control device is not a safety device.

The spool may get stuck at any position due to contamination of the control device, such as hydraulic fluid pollutant, wear debris and foreign matters in the system, etc.

In this case, the pump flow no longer observes the operator's instructions.

- Make sure the driven device can promptly reach a safety state (e.g. stop) with the emergency stop module.
- Always observe the cleanliness level according to ISO 4406: 20/18/15 ($< 90^\circ\text{C}$) or 19/17/14 ($> 90^\circ\text{C}$)

Correlation of Direction of rotation, Control and Flow direction

Direction of rotation (viewed on drive shaft)				
	Pilot Pressure	Control Pressure	Flow Direction	Working Pressure
CW	Y1	X1	A to B	MB
	Y2	X2	B to A	MA
CCW	Y1	X1	B to A	MA
	Y2	X2	A to B	MB

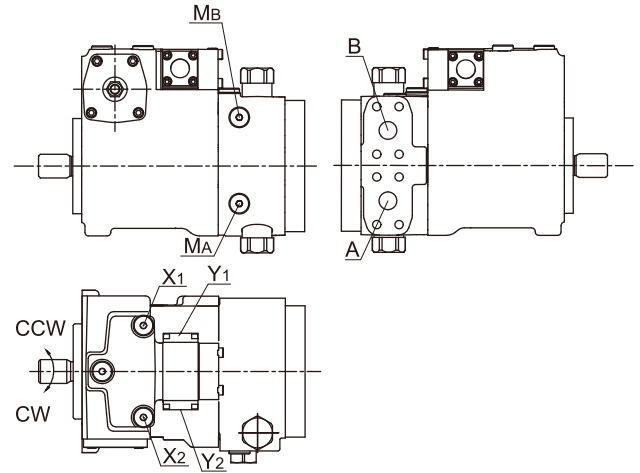

Circuit Diagram, HD3

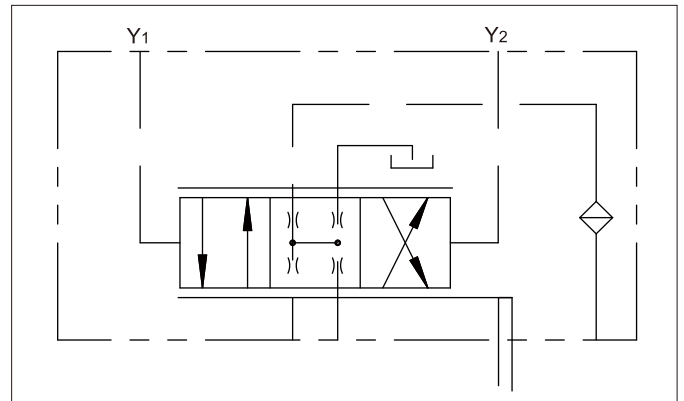



HW - Mechanical Servo Control

Dependent on the moving direction a or b of the control lever, the variable cylinder of the pump obtains control pressure via the HW controller so that the swashplate moves to infinitely adjust the displacement. Each moving direction of the control lever corresponds to one flow direction.

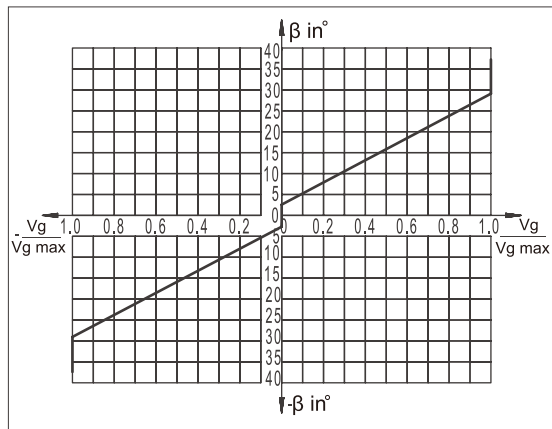

Swivel angle β of control lever:
 Start of control $\beta=3^\circ$
 End of control $\beta=29^\circ$ (maximum displacement $V_{g \max}$)
 Mechanical limit: $\pm 40^\circ$

The maximum required torque at the control lever is 170 Ncm.
 The rotation of HW control lever must be limited with an external position sensor (set point device).

Note:
 When there is no torque on the HW control lever, spring centering enables the pump to move automatically to the neutral position ($V_g = 0$) (independent of swivel angle).

Correlation of Direction of rotation, Control and Flow direction

Direction of rotation (viewed on drive shaft)				
	Pilot Pressure	Control Pressure	Flow Direction	Working Pressure
CW	a	X2	B to A	MA
	b	X1	A to B	MB
CCW	a	X2	A to B	MB
	b	X1	B to A	MA

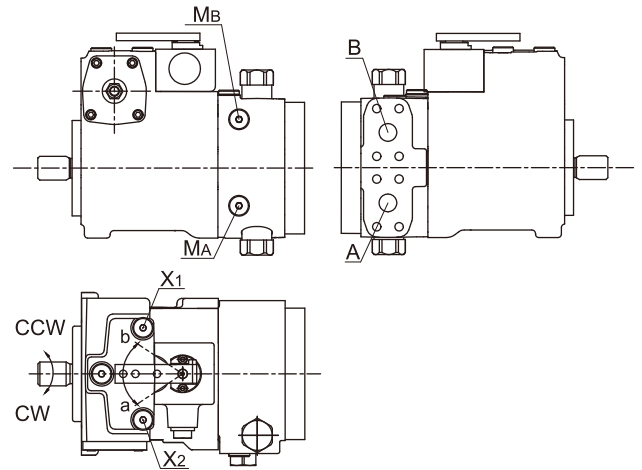

Circuit Diagram, HW

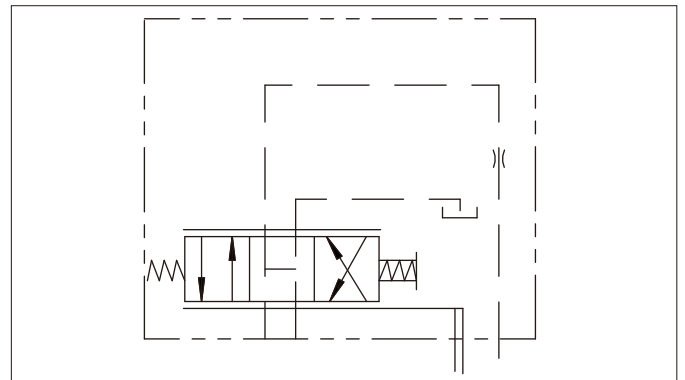



➤ HW - Mechanical Servo Control

Variant I: With Neutral Position Switch, HWL

The neutral position switch is closed when the control lever on the HW control valve is in its neutral position. The switch opens when the control lever is moved out of the neutral position in either direction. The neutral position switch protects the systems that required zero flow under certain working conditions, such as starting the engine.

Technical data, neutral position switch	
Switching capacity	5A/12V&3A/24V
Type of connector	AMP DJ7021-1. 8-20

Circuit diagram, HWL

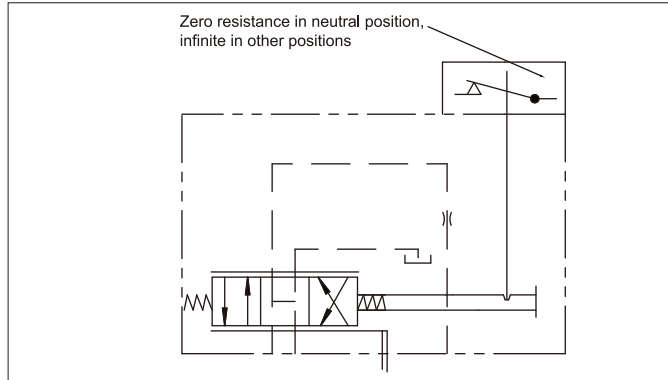

Variant II: With Brake Valve Switch, HWO/HWC

HWO:
with normally open brake valve; brake valve actuated when de-energized
HWC:
with normally closed brake valve; brake valve actuated when energized

Technical data, solenoid	HWO(C)1	HWO(C)2
Voltage	12V DC ± 1.8V	24V DC ± 3.6V
Nominal resistance(20°C)	9 Ω	36 Ω
Rated power	18W	18W
Minimum required current	1.5 A	0.75
Type of connector	DEUTSCH DT04-2P	
Duty cycle	100%	
Type of protection	IP67	

Circuit diagram, HWO With NO Brake Valve

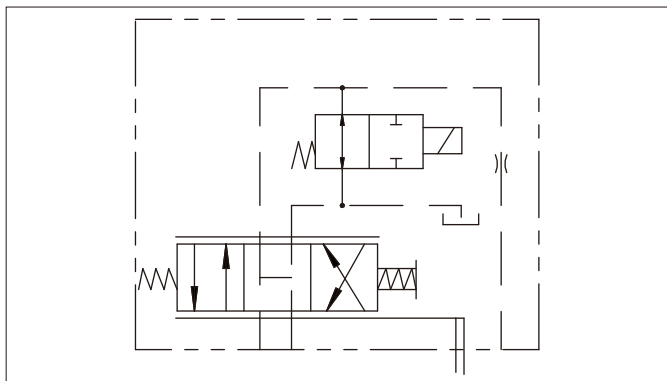

Circuit Diagram, HWC With NC Brake Valve

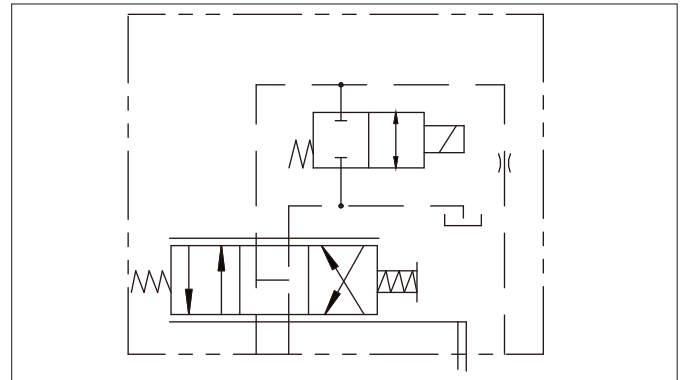

Variant III: With Brake Valve & Neutral Position Switch, HWOL/HWCL

Circuit Diagram, HWOL With NO Brake Valve & Neutral Position Switch

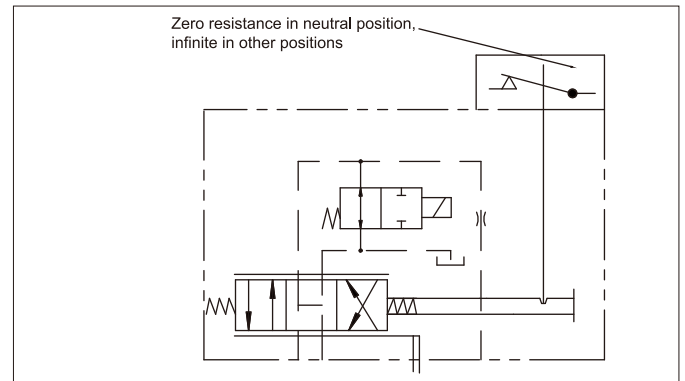

Circuit Diagram, HWCL With NO Brake Valve & Neutral Position Switch

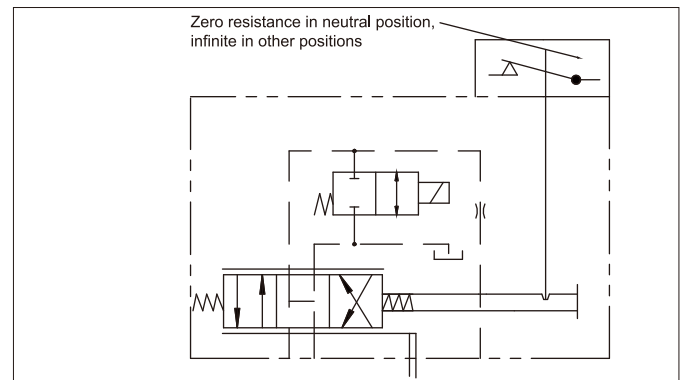



EP - Electric Control with Proportional Solenoid

Dependent on the preset current I of the two proportional solenoids (a and b), the variable cylinder of the pump obtains control pressure via the EP controller so that the swashplate moves to infinitely adjust the displacement. Each proportional solenoid corresponds to one flow direction.

Technical data, solenoid	EP1/EP3	EP2/EP4
Voltage	12V DC $\pm 20\%$	24V DC $\pm 20\%$
Start of control V_{g0}	400mA	200mA
End of control $V_{g \max}$	1200mA	600mA
Current limit	1.54A	0.77A
Nominal resistance (20°C)	5.5 Ω	22.7 Ω
Dither frequency	100Hz	
Type of connector	DEUTSCH DT04-2P	
Duty cycle	100%	
Type of protection	IP67	

EP1\EP2: without inlet filter (Not for new projects!)
 EP3\EP4: with inlet filter (standard)

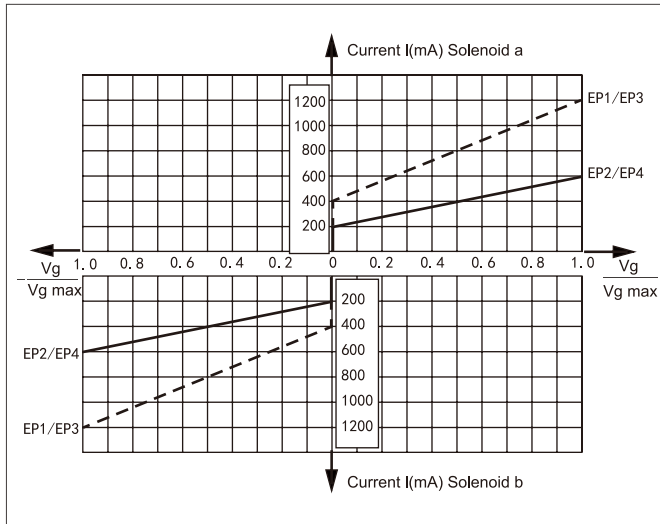

Note:
 The spring at the center of the pilot control device is not a safety device. The spool may get stuck at any position due to contamination of the control device, such as hydraulic fluid pollutant, wear debris and foreign matters in the system, etc.
 In this case, the pump flow no longer observes the operator's instructions.
 - Make sure the driven device can promptly reach a safety state (e.g. stop) with the emergency stop module.
 - Always observe the cleanliness level according to ISO 4406: 20/18/15 (< 90 °C) or 19/17/14 (> 90 °C)

Correlation of Direction of rotation, Control and Flow direction

Direction of rotation (viewed on drive shaft)				
	Proportional Solenoid	Control Pressure	Flow Direction	Working Pressure
CW	a	X1	A to B	M _B
	b	X2	B to A	M _A
CCW	a	X1	B to A	M _A
	b	X2	A to B	M _B

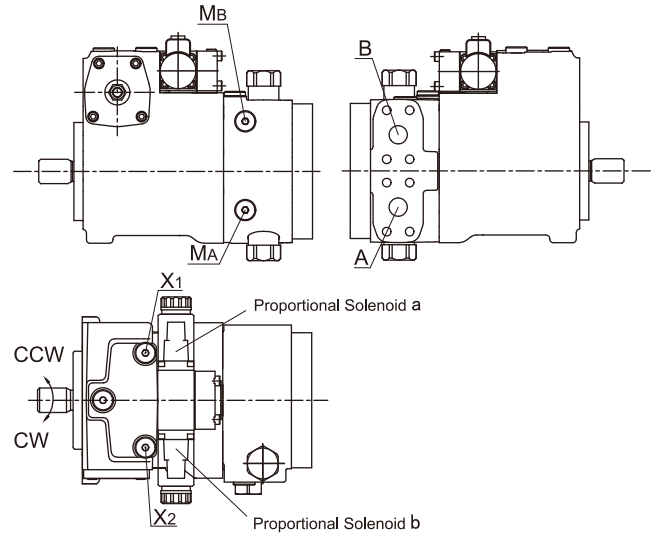

Circuit Diagram, EP1/2

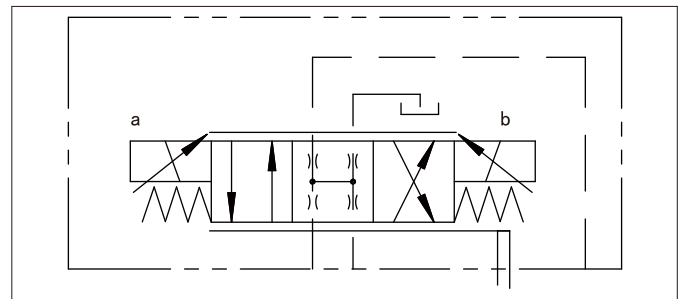

Circuit Diagram, EP3/4

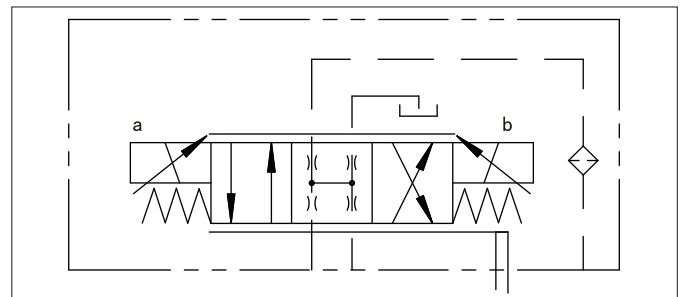



➤ EZ - Electric Control with Switching Solenoid

By switching on or off the switching solenoid a or b, the control cylinder of the pump obtains control pressure via the EZ controller so that the swashplate realizes adjustment between $V_g=0$ and $V_g \text{ max}$. Each solenoid corresponds to one flow direction.

Correlation of Direction of rotation, Control and Flow direction

Direction of rotation (viewed on drive shaft)				
	Proportional Solenoid	Control Pressure	Flow Direction	Working Pressure
CW	a	X2	B to A	MA
	b	X1	A to B	MB
CCW	a	X2	A to B	MB
	b	X1	B to A	MA

Technical data, solenoid	EZ1/3	EZ2/4
Voltage	12V DC(±20%)	24V DC(±20%)
Neutral position $V_g=0$	De-energized	De-energized
Position $V_g \text{ max}$	Energized	Energized
Nominal resistance(20°C)	5.5Ω	21.7Ω
Rated power	26.2W	26.5W
Minimum required current	1.32A	0.67A
Type of connector	DEUTSCH DT04-2P	
Duty cycle	100%	
Type of protection	IP67	

Standard: switching solenoid without manual emergency control. The manual emergency control realized by returning spring may be provided as required.

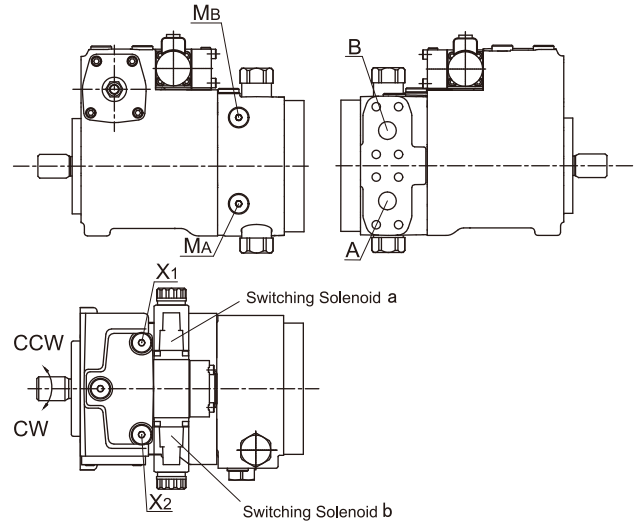

Circuit Diagram, EZ1/2

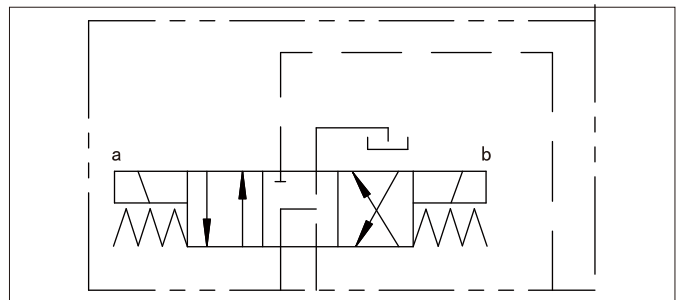

Circuit Diagram, EZ3/4

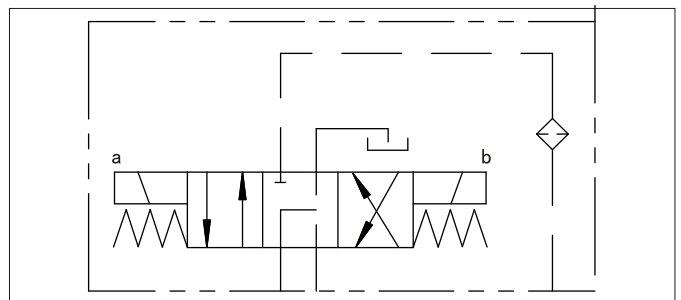



High Pressure Relief Valve

Setting Range

High-pressure relief valve, direct operated (size 28/45/53)	Differential pressure setting Δp_{HP}
Setting range valve 2 $\Delta p=35-45\text{MPa}$	36MPa
	38MPa
	40MPa
	42MPa
Setting range valve 3 $\Delta p=25-34\text{MPa}$	44MPa
	26MPa
	28MPa
	30MPa
	32MPa
	34MPa
Setting range valve 4 $\Delta p=10-24\text{MPa}$	10MPa
	12MPa
	14MPa
	16MPa
	18MPa
	20MPa
	22MPa
	24MPa
Setting range valve 5 $\Delta p=25-34\text{MPa}$	26MPa
	28MPa
	30MPa
	32MPa
	34MPa
Setting range valve 6 $\Delta p=10-24\text{MPa}$	10MPa
	12MPa
	14MPa
	16MPa
	18MPa
	20MPa
	22MPa
	24MPa
Setting range valve 7 $\Delta p=35-45\text{MPa}$	36MPa
	38MPa
	40MPa
	42MPa
	44MPa

Standard differential pressure setting.
Values when no special remarks are made when ordering.

Pressure Setting Diagram

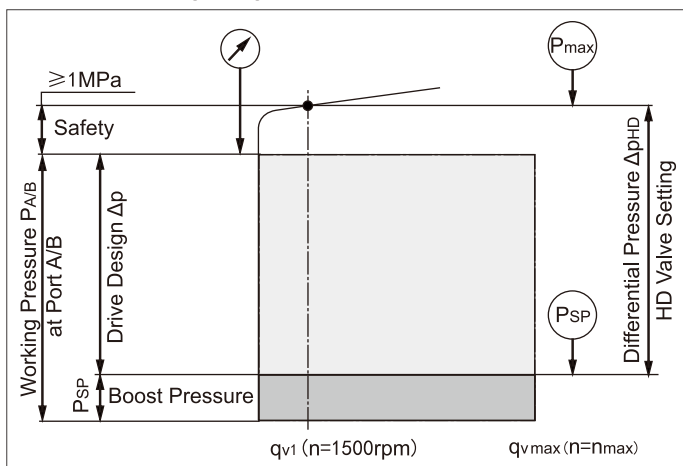

Note: The high-pressure relief valve is set at $n = 1500\text{rpm}$ and $V_{g \max}$ (q_{v1}).
Hint: boost pressure 2MPa, working pressure 29MPa
Working pressure $P_{A/B}$ - Pressure P_{SD}
= differential pressure Δp_{HP} ($29-2=27\text{MPa}$)

Bypass Function

Valves 5/6/7 have the bypass function, The bypass function is only intended for short-term operation at reduced displacement, for example to tow a vehicle out of a danger zone.

Pressure Cutoff Valve, D

The pressure cut-off is a pressure control which adjusts the displacement of the pump to $V_{g \min}$ after the set pressure is reached. The pressure cut-off valve prevents the operation of the high-pressure relief valve during acceleration or deceleration. The high-pressure relief valve protects against pressures occurring during fast swiveling of the swashplate and maximum pressure in the system. The setting range of the pressure cut-off valve may be anywhere within the entire working pressure range. However, the range must be set 3 MPa lower than the setting of the high-pressure relief valve.

Mechanical Stroke Limite, M

The mechanical stroke limiter is an auxiliary function for continual reduction of the maximum displacement of the pump, regardless of the control device used. Two adjusting screws are used to limit the stroke of the stroking cylinder and thus the maximum swivel angle of the pump.

Mounting Flange

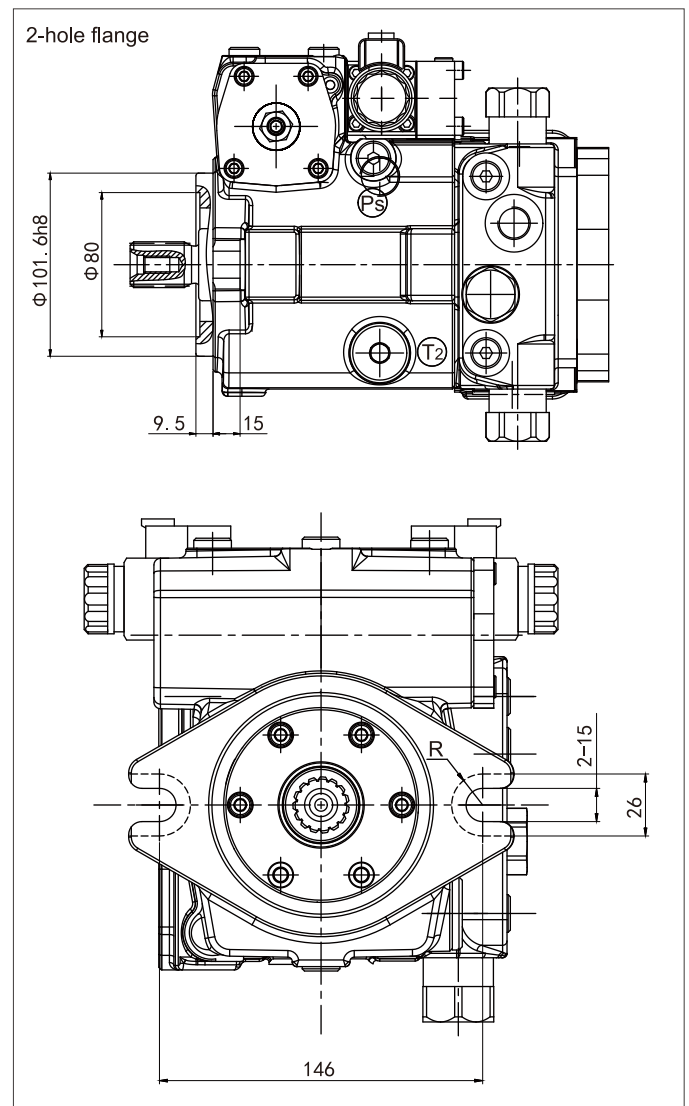



► Installation Dimensions

Size 28
Without Control Valve

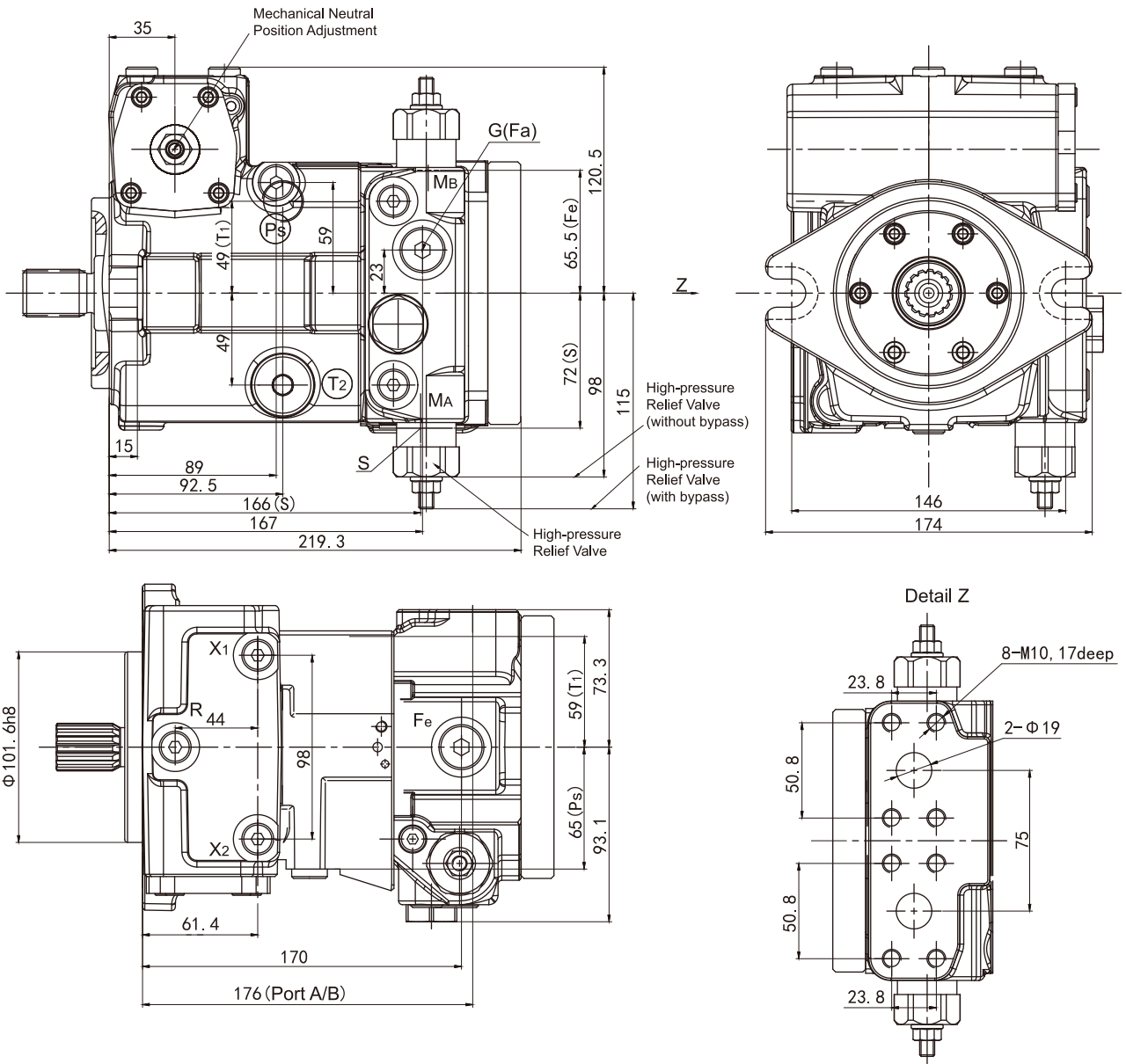

Ports

A/B	Working port (high pressure series)	SAE J518 3/4"
	Fastening thread	DIN13 M10x1.5, 18deep
T1	Case drain port or filling port	DIN3852 M22x1.5, 17deep
T2	Case drain port	DIN3852 M22x1.5, 17deep
MA/Mb	Measuring port pressure	DIN3852 M12x1.5, 14deep
R	Air bleed port	DIN3852 M12x1.5, 15deep
S	Boost suction port	DIN3852 M33x2, 20deep
X1/X2	Control pressure port	DIN3852 M12x1.5, 15deep
G(Fa)	Pressure port, auxiliary circuit	DIN3852 M18x1.5, 14deep
Ps	Control pressure inlet port	DIN3852 M14x1.5, 14deep
Fe	Filter outlet	DIN3852 M18x1.5, 15deep

Drive shaft S
SAE J744-25-4(B-B)
Φ1" 15T 16/32DP

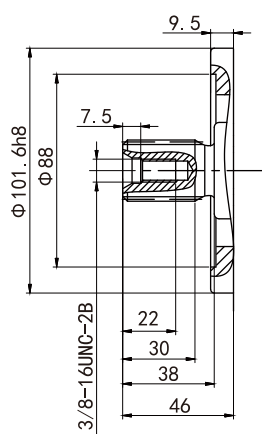

Drive shaft T
SAE J744-32-4(C)
Φ1 1/4" 14T 12/24DP

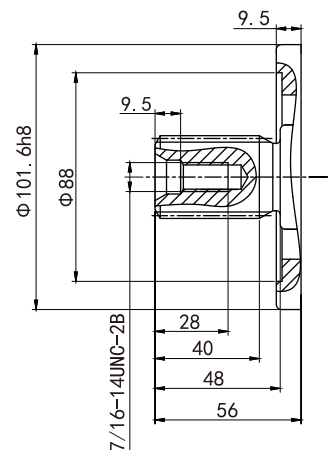



► Installation Dimensions

HD pilot pressure control

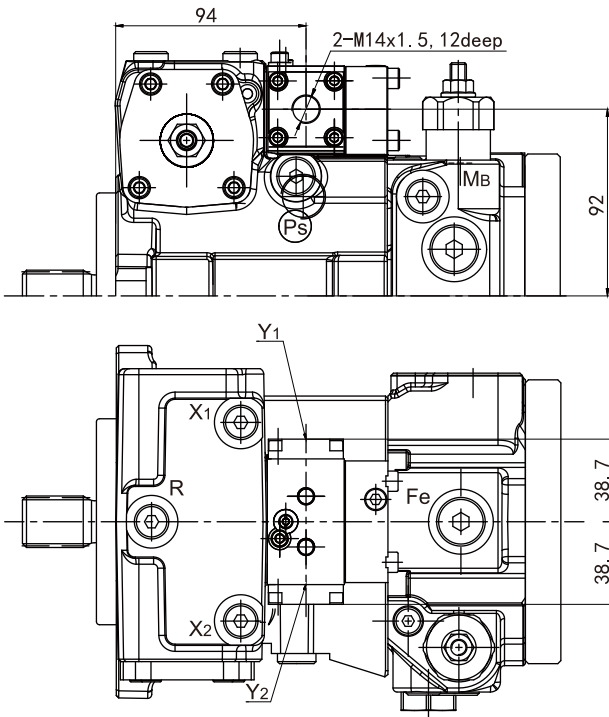

HW mechanical servo control

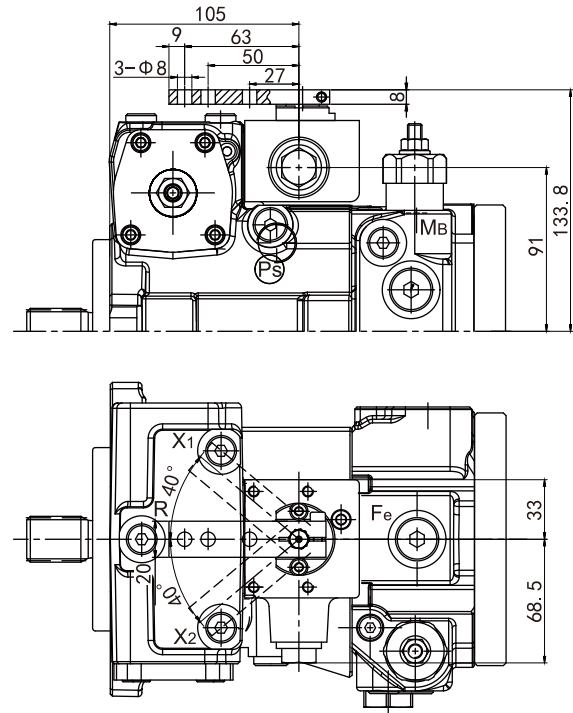

EP electric control, with proportional solenoid

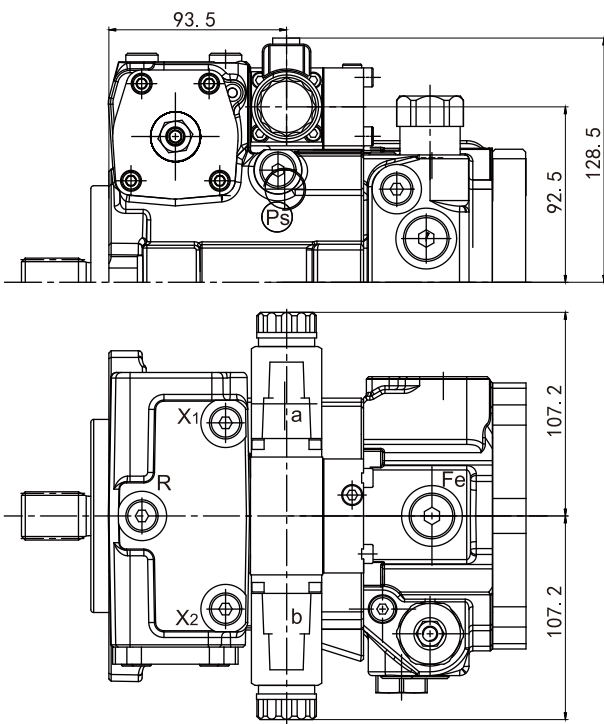



➤ Installation Dimensions

Without through drive F00/N00

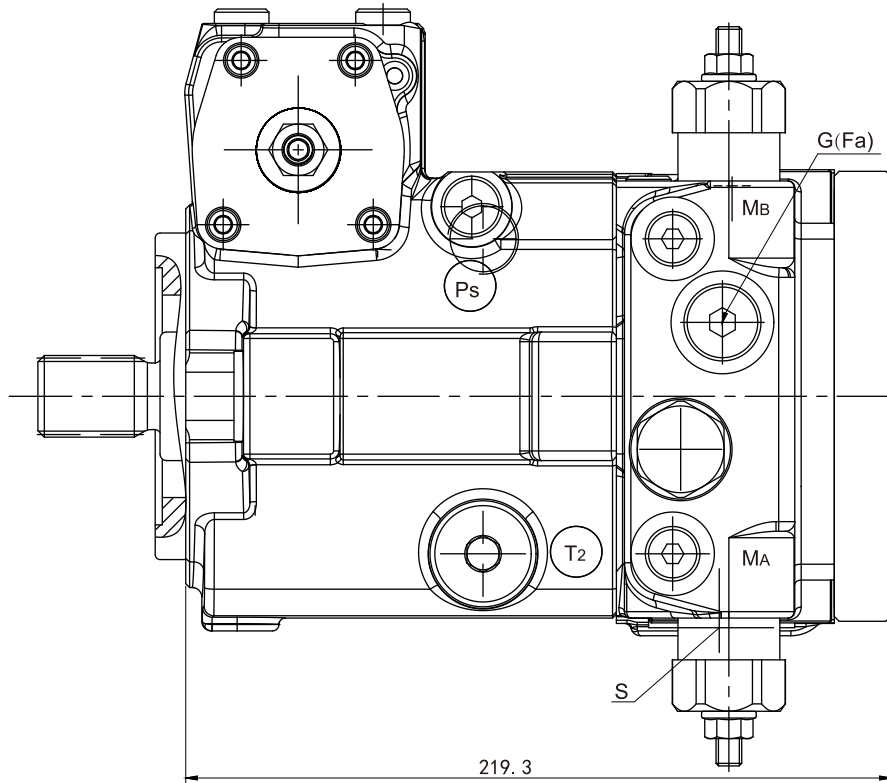

With through drive F01/K01(5.8mL/r boost pump)
Flange SAE J744-82-2(A)

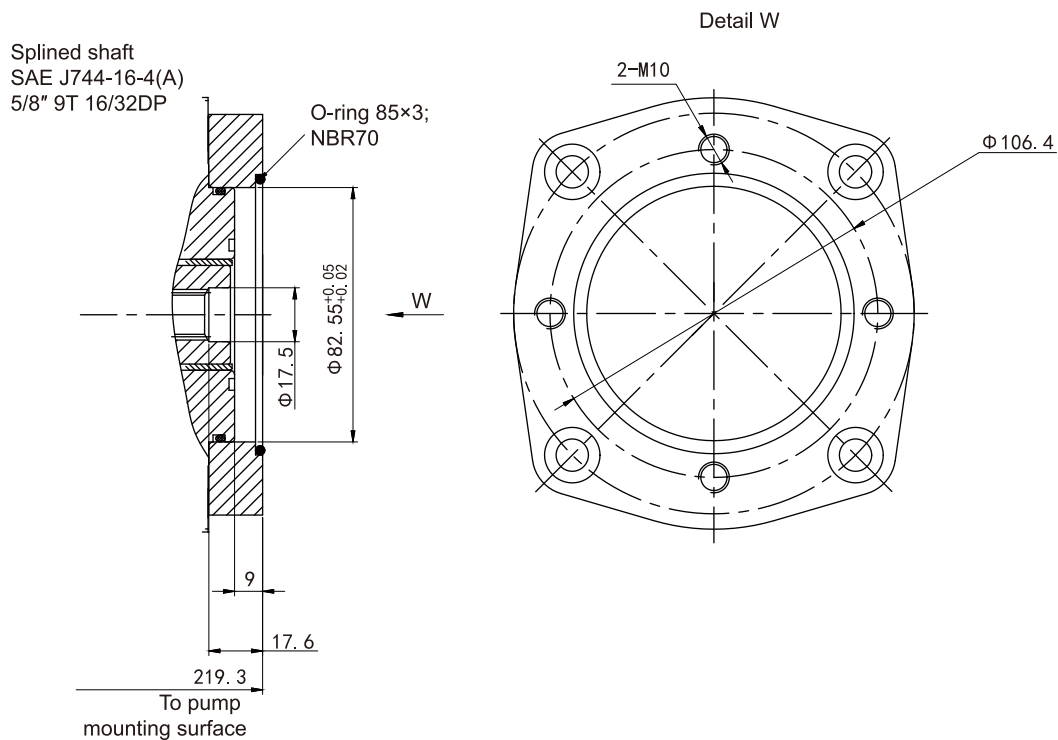



► Installation Dimensions

With through drive F01/K01(13.8mL/r boost pump)
 Flange SAE J744-82-2(A)

Splined shaft
 SAE J744-16-4(A)
 5/8" 9T 16/32DP

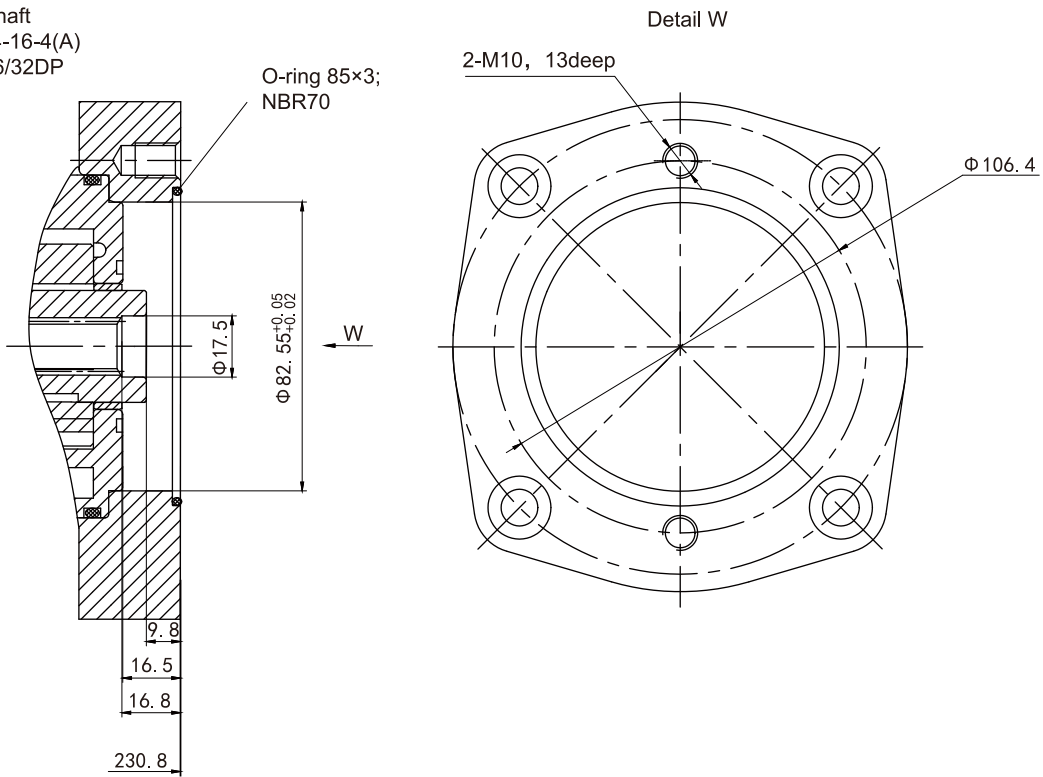

With through drive F02/K02(13.8mL/r boost pump)
 Flange SAE J744-101-2(B)

Splined shaft
 SAE J744-22-4(B)
 7/8" 13T 16/32DP

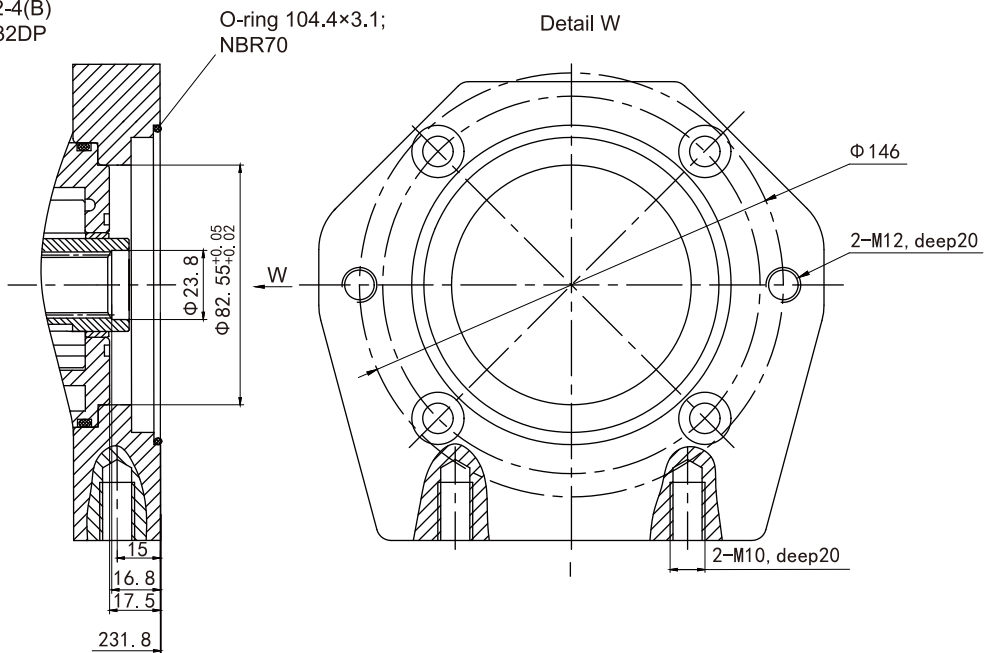



► Installation Dimensions

Size 45/53
Without control valve

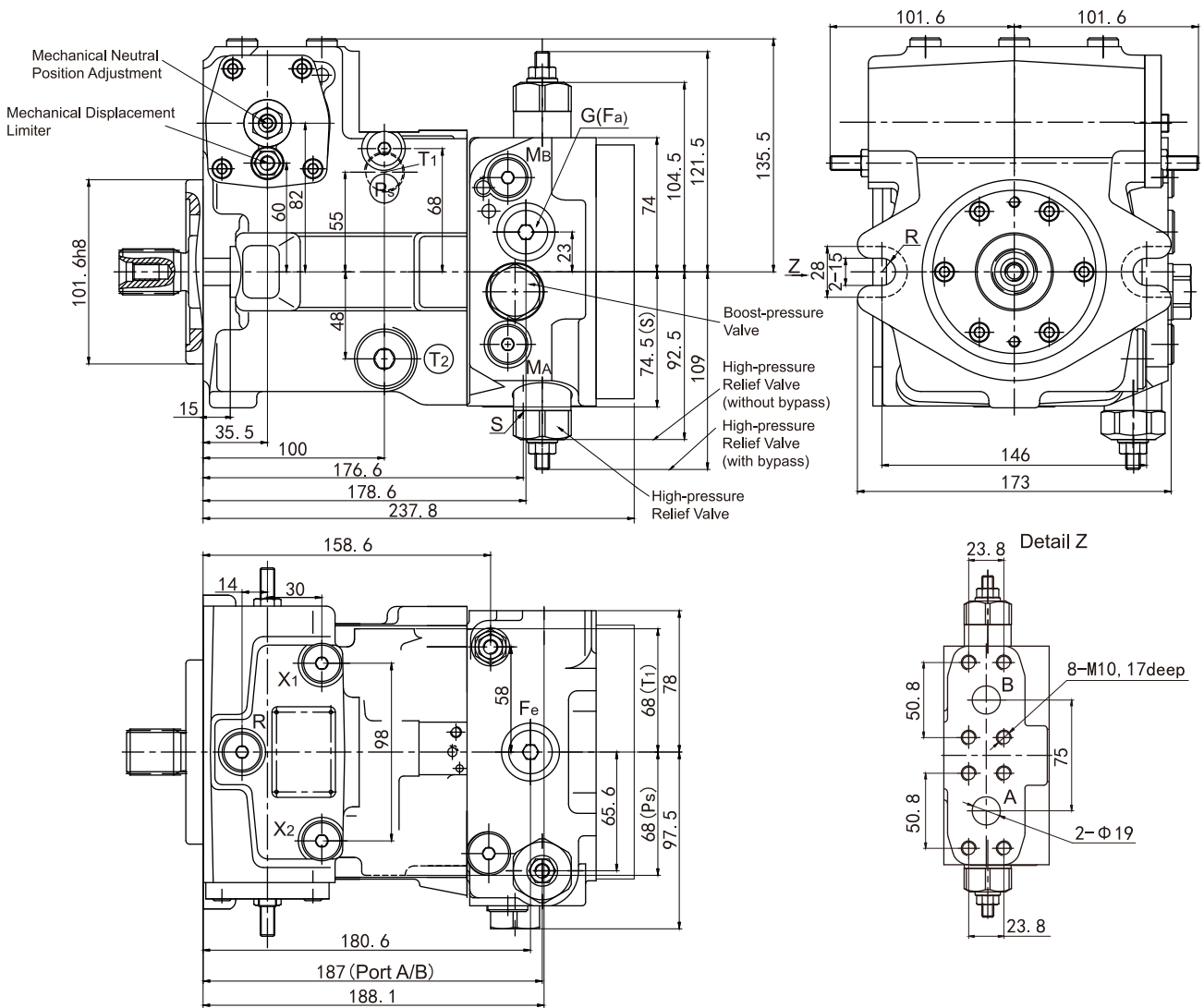

Ports

A/B	Working port (high pressure series)	SAE J518 3/4"
	Fastening thread	DIN13 M10x1.5, 17deep
T1	Case drain port or filling port	DIN3852 M22x1.5, 17deep
T2	Case drain port	DIN3852 M22x1.5, 17deep
MA/MB	Measuring port pressure	DIN3852 M12x1.5, 14deep
R	Air bleed port	DIN3852 M12x1.5, 15deep
S	Boost suction port	DIN3852 M33x2, 19deep
X1/X2	Control pressure port	DIN3852 M12x1.5, 14deep
G(Fa)	Pressure port, auxiliary circuit	DIN3852 M18x1.5, 14deep
Ps	Control pressure inlet port	DIN3852 M14x1.5, 14deep
Fe	Filter outlet	DIN3852 M18x1.5, 14deep

Drive shaft S
SAE J744-25-4(B-B)
Φ1" 15T 16/32DP

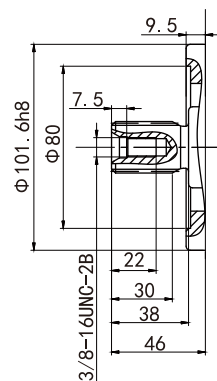

Drive shaft T
SAE J744-32-4(C)
Φ1 1/4" 14T 12/24DP

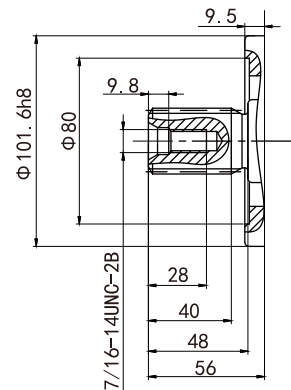



> Installation Dimensions

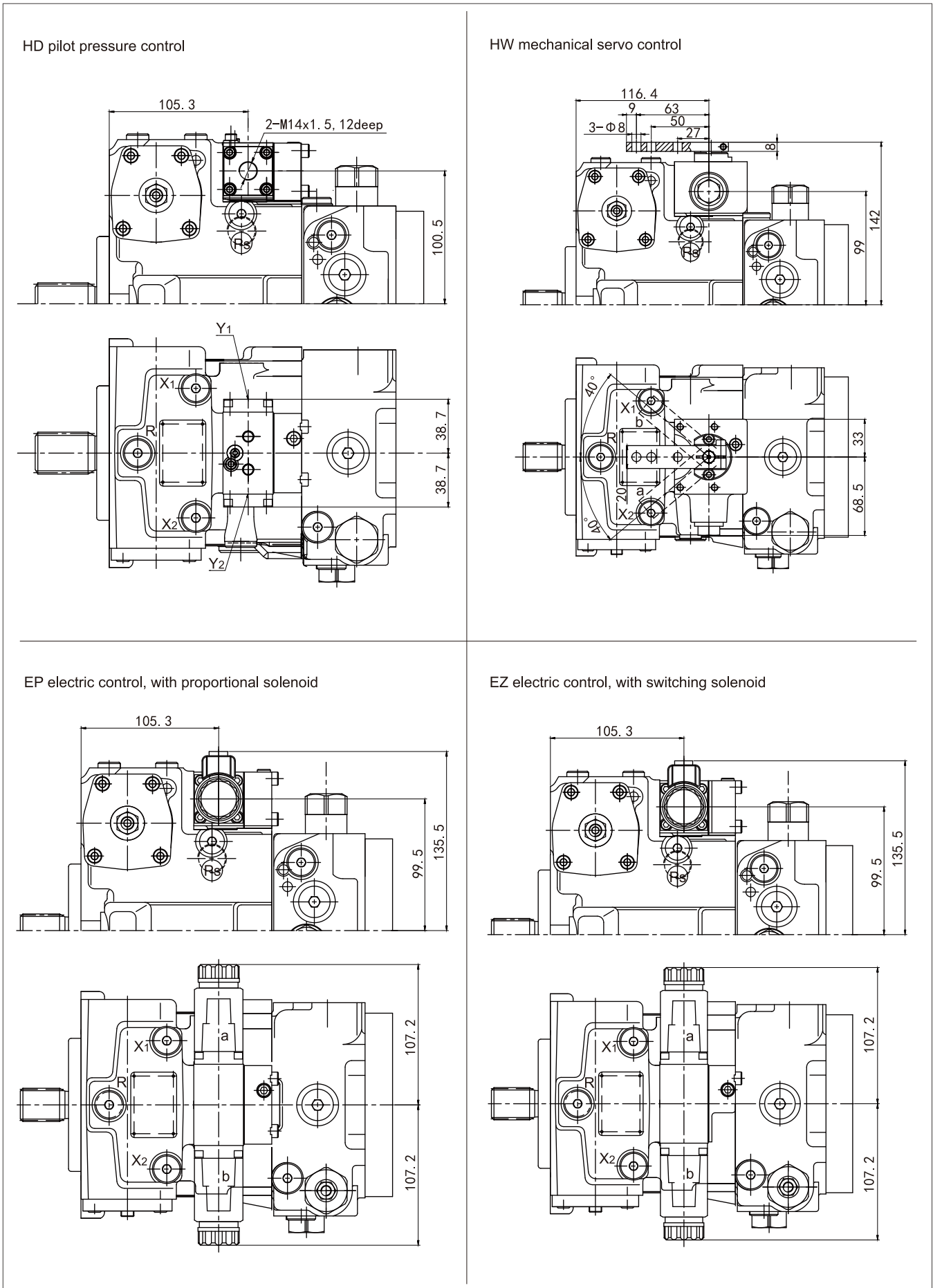



Installation Dimensions

Without through drive F00/N00

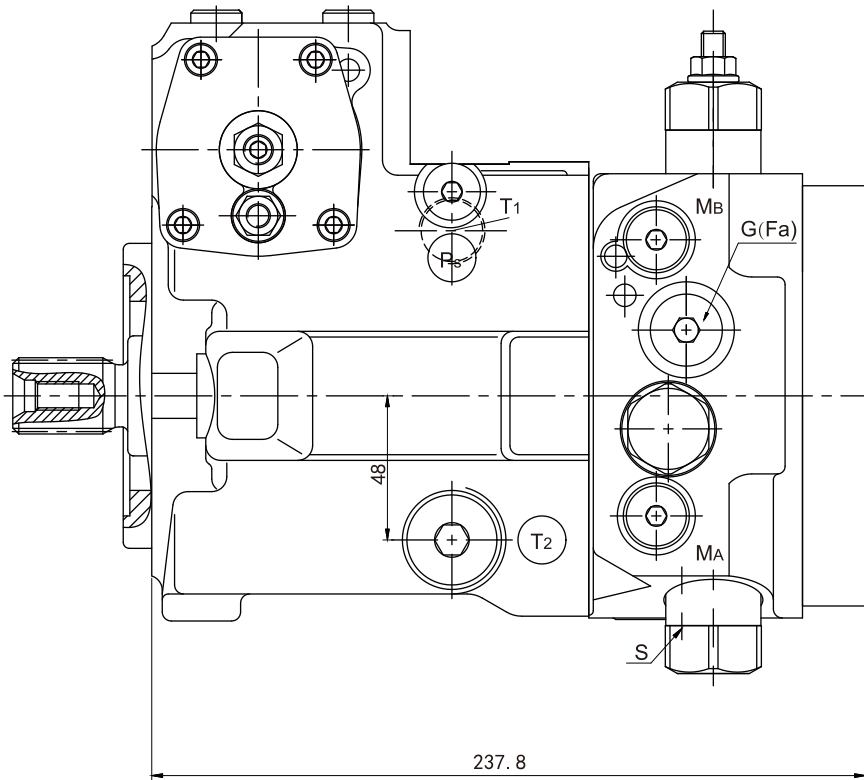

With through drive F01/KO1
Flange SAE J744-82-2(A)

Splined shaft
SAE J744-16-4(A)
5/8" 9T 16/32DP

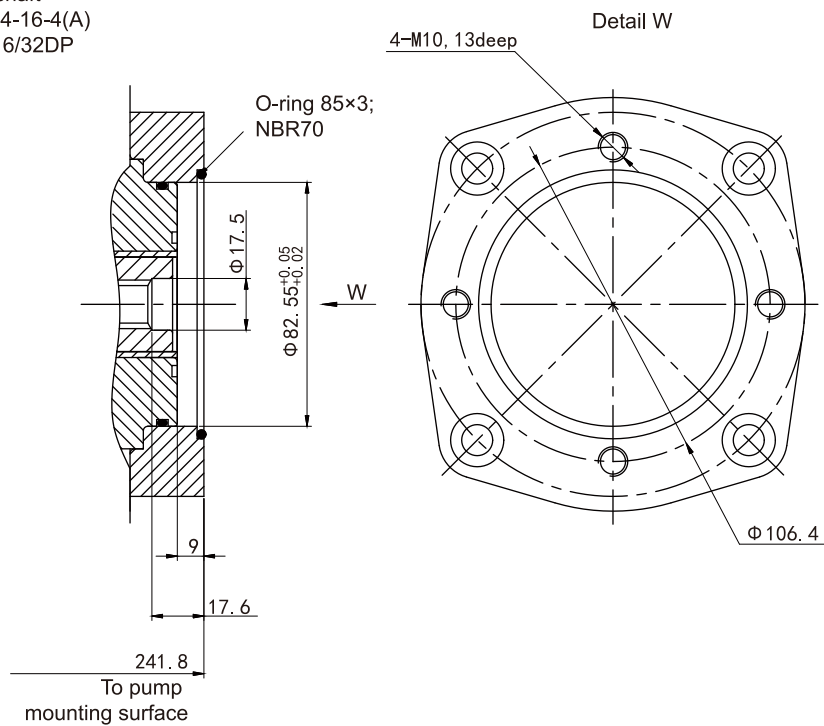



➤ Installation Dimensions

With through drive F04/K04
Flange SAE J744-101-2(B)

Splined shaft
SAE J744-25-4(B-B)
1" 15T 16/32DP

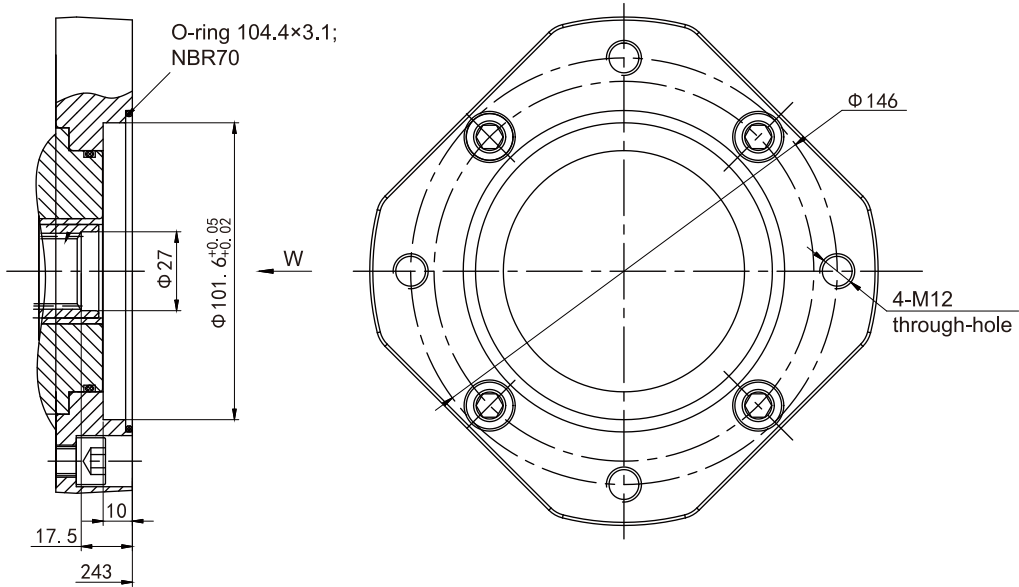

With through drive F02/K02
Flange SAE J744-101-2(B)

Splined shaft
SAE J744-101-2(B)
7/8" 13T 16/32DP

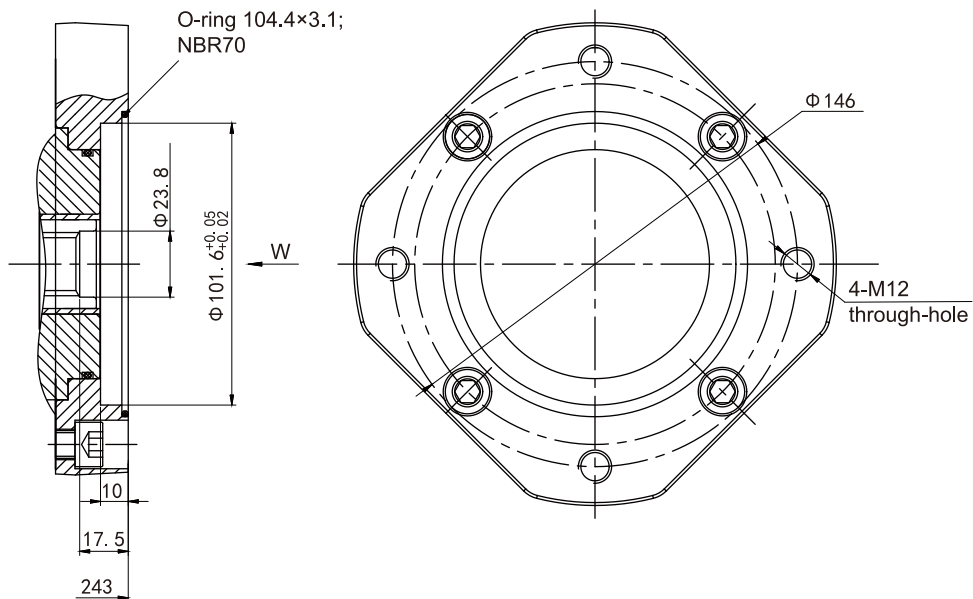



> Filtration

Standard: Filtration in Boost Pump Suction Line, S

Standard type (preferred)

Type of filter : filter without bypass

Recommendation: with contamination indicator

Flow resistance at filter element:

$V=30\text{mm}^2/\text{s}$, $n=n_{\text{max}}$ $\Delta p \leq 0.1\text{bar}$

$V=1000\text{mm}^2/\text{s}$, $n=n_{\text{max}}$ $\Delta p \leq 0.3\text{bar}$

Pressure at suction port S:

$V=30\text{mm}^2/\text{s}$, $n=n_{\text{max}}$ $\Delta p \geq 0.8\text{bar}$

Cold start ($V=1600\text{mm}^2/\text{s}$ 时, $n \leq 1000\text{rpm}$) $\Delta p \geq 0.5\text{bar}$

The filter is not included in the scope of delivery.

Circuit Diagram-Standard, S

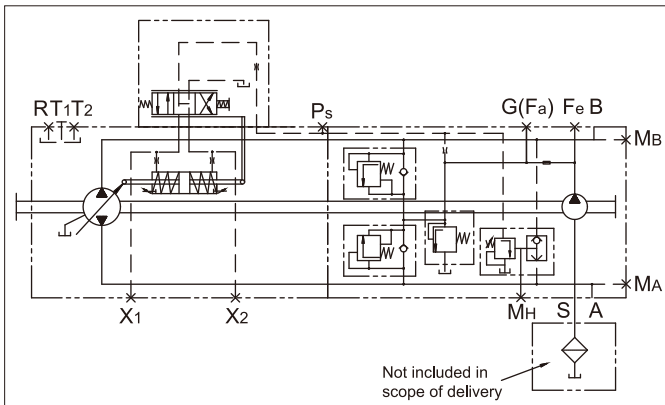

Variant II: Filtration in Boost Pump Pressure Line, with Ports for External Boost Circuit Filtration, D

Filter inlet: port Fe
Filter outlet: port Fa

Type of filter:

- Filters with bypass are not recommended
- Filters with contamination indicator are recommended

The filter is not included in our scope of delivery.

Circuit Diagram-Variant II, D

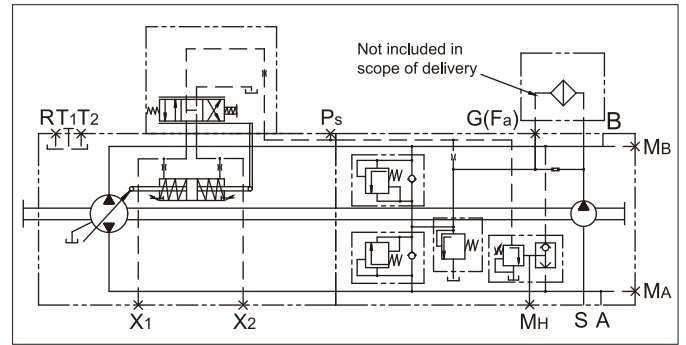

Variant I: External Fluid Supply, E

This version is used for models without integrated boost pump, N00 or K...

Port S plugged, fluid supply from port Fa or Fa1.

Filter arrangement: separately installed to ensure stable functioning and fluid cleanliness level at port Fa or Fa1 (see "Technical Data - Filter").

Circuit Diagram-Variant I, E

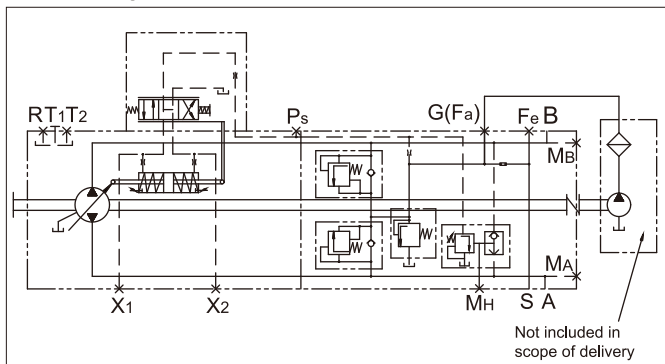



Connector for Solenoids

DEUTSCH DT04-2P-EP04, 2-pin
Molded, without bidirectional suppressor diode_____P

The following type of protection ensues with the installed mating connector:

- IP67(DIN EN 60520)
- IP69K(DIN 60050-9)

Switching Symbol

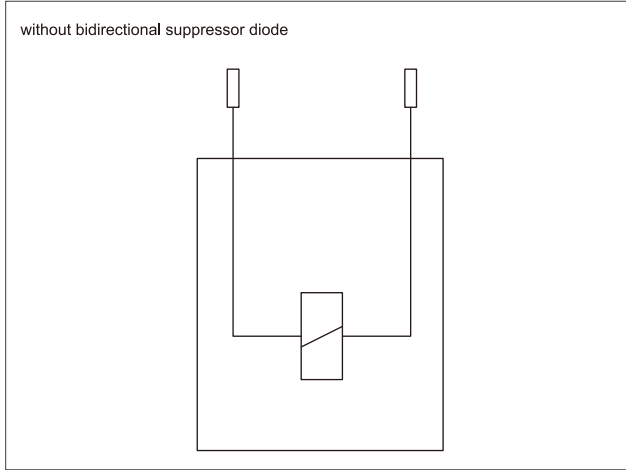

Mating Connector

DEUTSCH DT06-2S-EP04

Consisting of	DT
1 housing	DT06-2S-EP04
1 wedge	W2S
2 sockets	0462-201-16141

The mating connector is not included in the scope of delivery.

With emergency start and spring reset for Solenoid(EP/EZ)

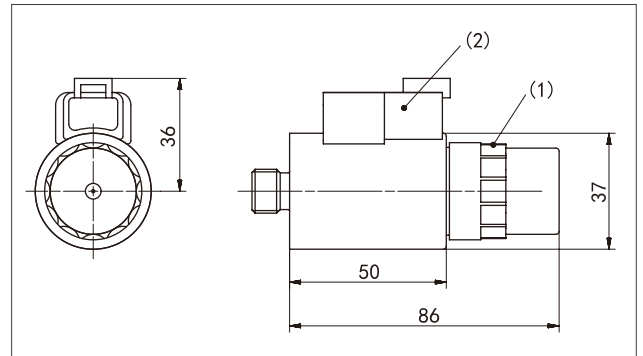

Brake Valve Solenoid (HWC/O)

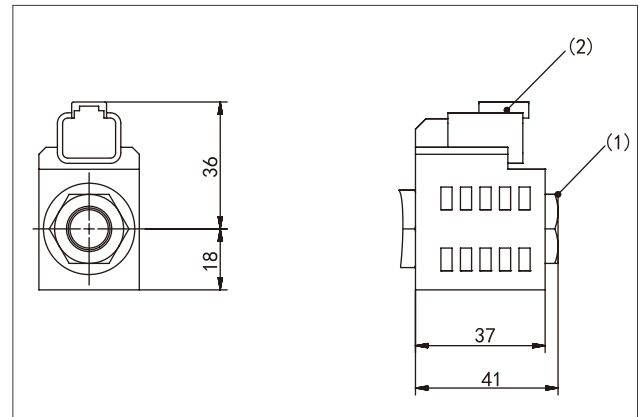

Notice

Manual emergency operation (emergency start) can be used in case of electrical system failure.

If necessary, you can change the position of the connector by turning the solenoid.

The position of the connectors varies of delivery.



Installation Instructions

General

The axial piston unit must be always be filled with hydraulic fluid and air bled during commissioning and operation. This must also be observed following a longer standstill as the system may empty via the hydraulic lines. The leakage in the housing must be directed to the reservoir via the highest drain port. The minimum suction pressure at port S must not fall below 0.08 MPa absolute pressure (or 0.05 MPa absolute pressure at cold start). Under all operating conditions, the suction line and case drain line must flow into the reservoir below the minimum fluid level.

Installation Positions

See the examples below. Other installation positions may be provided as required.

Below-Reservoir Installation (standard)

Pump below the minimum fluid level of the reservoir. Recommended installation positions: 1 and 2.

Above-Reservoir Installation

Pump above the minimum fluid level of the reservoir. Do not exceed the maximum permissible suction height $h_{max}=800mm$.

Recommendation for installation position 8 (shaft upwards):

Draining inside the housing may be prevented by installing a check valve (cracking pressure 0.05 MPa) in the drain line.

①		②		⑤		⑥																															
③		④		⑦		⑧																															
<table border="1"> <thead> <tr> <th>Installation Position</th> <th>Air Bleed</th> <th>Filling Port</th> </tr> </thead> <tbody> <tr> <td>1</td> <td>R</td> <td>S+T1 (L2)</td> </tr> <tr> <td>2</td> <td>L2</td> <td>S+T2 (L2)</td> </tr> <tr> <td>3</td> <td>L2</td> <td>S+T2 (L2)</td> </tr> <tr> <td>4</td> <td>R+L2</td> <td>S+T2 (L2)</td> </tr> </tbody> </table>				Installation Position	Air Bleed	Filling Port	1	R	S+T1 (L2)	2	L2	S+T2 (L2)	3	L2	S+T2 (L2)	4	R+L2	S+T2 (L2)	<table border="1"> <thead> <tr> <th>Installation Position</th> <th>Air Bleed</th> <th>Filling Port</th> </tr> </thead> <tbody> <tr> <td>5</td> <td>R</td> <td>T1+L3</td> </tr> <tr> <td>6</td> <td>L2</td> <td>S (L3) +T2 (L2)</td> </tr> <tr> <td>7</td> <td>L2+L3</td> <td>S (L3) +T2 (L2)</td> </tr> <tr> <td>8</td> <td>R+L3</td> <td>S (L3) +T2</td> </tr> </tbody> </table>				Installation Position	Air Bleed	Filling Port	5	R	T1+L3	6	L2	S (L3) +T2 (L2)	7	L2+L3	S (L3) +T2 (L2)	8	R+L3	S (L3) +T2
Installation Position	Air Bleed	Filling Port																																			
1	R	S+T1 (L2)																																			
2	L2	S+T2 (L2)																																			
3	L2	S+T2 (L2)																																			
4	R+L2	S+T2 (L2)																																			
Installation Position	Air Bleed	Filling Port																																			
5	R	T1+L3																																			
6	L2	S (L3) +T2 (L2)																																			
7	L2+L3	S (L3) +T2 (L2)																																			
8	R+L3	S (L3) +T2																																			









Since 2002

Over twenty years of deep cultivation in the field of hydraulic Solutions

HYTEK is a high technology enterprise integrating R&D, production, sales and service of hydraulic power products. Provides professional hydraulic transmission control products and solutions for construction machinery, road machinery, material handling machinery, agricultural and forestry machinery, industrial equipment and other fields. After more than 20 years of continuous R&D, technological innovation, market development and application services, technical level and the scale of production and sales have been on the forefront of the industry. Hytek has been committed to helping the development of subdivided industries with innovative hydraulic technology, "focusing on the challenges and pressures of customers, providing competitive products and solutions, reducing costs and increasing efficiency for customers, and continuously creating maximum value".

Product Series

- Open Circuit Pump
- Closed Circuit Pump
- Fixed Displacement Motor
- Variable Displacement Motor
- Hydrostatic Transmission Unit
- Internal Gear Pump
- Vane Pump
- Proportional valve/
Industrial Hydraulic Valve

For more information, please visit our official website and social media: en.hytek.cn



@Hytek Power

HYTEK POWER CO.,LTD.

No. 99, Shengyuan Road, Tengqiao Town, Lucheng District, Wenzhoucity 325029, Zhejiang, CHINA
 Email: globalsales@hytek.cn

America Canada Germany Italy Russia Türkiye Australia South Korea Thailand India Indonesia South Africa

HYTEK-REV1.0 04/2026

If there are any other modifications, no further notice will be given.