



Axial Piston Variable Pump HA10V(S)O Series 31

Size: 18 mL/r (HA10VSO)
Size: 28-140 mL/r (HA10VO)
Rated pressure: 28 MPa
Max. pressure: 35 MPa



Features



- ◆ Axial piston variable pump of swashplate design for open circuits
- ◆ Through drive available for multi-circuit systems
- ◆ Flow proportional to drive speed and displacement
- ◆ Infinitely variable by adjusting angle of swashplate
- ◆ Mounting flange according to ISO or SAE standard
- ◆ Metric SAE flange connection or UNC fastening thread
- ◆ Two case drain ports
- ◆ Excellent suction characteristics
- ◆ The drive shaft allows axial and radial loading
- ◆ High power to weight ratio
- ◆ Diverse control options, short control response time

Contents



- ◆ Model Code.....02
- ◆ Structure.....06
- ◆ Technical Data.....08
- ◆ Characteristic Curve.....09
- ◆ Drive Power and Flow.....10
- ◆ Installation Dimensions,18.....12
- ◆ Installation Dimensions,28.....13
- ◆ Installation Dimensions,45.....14
- ◆ Installation Dimensions,71.....15
- ◆ Installation Dimensions,100/110.....16
- ◆ Installation Dimensions,140.....17
- ◆ DR Pressure Control.....18
- ◆ DRG Pressure/Remotely Control.....19
- ◆ ED Electro-proportional Remote Pressure Control...20
- ◆ DFR/DFR1 Pressure/Flow Control.....21
- ◆ DFLR Pressure/Flow/Constant Power Control...22
- ◆ Installation Dimensions-DR.....24
- ◆ Installation Dimensions-ED.....25
- ◆ Installation Dimensions-DFR/DFR1.....26
- ◆ Installation Dimensions-DFLR.....27
- ◆ Installation Dimensions-Combination Pumps.....29
- ◆ Installation Dimensions-Through Drive.....30
- ◆ Installation Instructions.....40



> Model Code

	c	A	B		I	K		M	N	P	R	S	X		Z
HA10V(S)	O			/	3 1		-							-	

Axial piston unit

		18	28	45	71	100	110	140	
—	Swashplate design, variable piston pump	●	—	—	—	—	—	—	HA10VS
		—	●	●	●	●	●	●	HA10V

Operation

c	Open circuit	O
---	--------------	---

Displacement

A	Geometric displacement, in mL/r	18	28	45	71	100	110	140	
---	---------------------------------	----	----	----	----	-----	-----	-----	--

Variable control method

B	Pressure control	Remote pressure control	Hydraulic	●	●	●	●	●	●	●	DR	
			Electric negative	U=12V DC	○	○	○	○	○	○	○	ED71
				U=24V DC	●	●	●	●	●	●	○	ED72
			Pressure/flow control (with damping hole in X-line)			●	●	●	●	●	●	●
	Pressure/flow control (without damping hole in X-line)			●	●	●	●	●	●	●	DFR1	
	Pressure/flow/power control			—	●	●	●	●	●	●	DFLR	

Series

I		18	28	45	71	100	110	140	
	Series 31	●	●	●	●	●	●	●	31

Direction of rotation (viewed on shaft end)

K		18	28	45	71	100	110	140	
	CW	●	●	●	●	●	●	●	R
	CCW	●	●	●	●	●	●	●	L

Sealing material

M		18	28	45	71	100	110	140	
	NBR seal + FKM Shaft seal	●	●	●	●	●	●	●	N
	NBR seal	●	●	●	●	●	●	●	P
	FKM seal	●	●	●	●	●	●	●	V



> Model Code

	c	A	B		I	K		M	N	P	R	S	X		Z
HA10V(S)	O			/	3 1		-							-	

Drive shaft

N		18	28	45	71	100	110	140	
	Parallel keyed shaft DIN 6885	●	●	●	●	●	●	●	P
	Parallel keyed shaft SAE J744	●	●	●	●	●	●	●	K
	Splined shaft SAE B92.1(not applicable to through drive)	5/8"	—	7/8"	—	1 1/4"	1 1/4"	—	U
	Splined shaft SAE B92.1	3/4"	7/8"	1"	1 1/4"	1 1/2"	1 1/2"	1 3/4"	S
	Splined shaft SAE B92.1(high through-drive torque)	—	7/8"	1"	1 1/4"	—	—	—	R

Mounting flange

P		18	28	45	71	100	110	140	
	2-hole, ISO 3019-2	●	●	●	●	●	●	—	A
	4-hole, ISO 3019-2	—	—	—	—	—	—	●	B
	2-hole, SAE J744	●	●	●	●	●	●	—	C
	4-hole, SAE J744	—	—	—	—	—	—	●	D

Working port

R	SAE port flange, metric fastening thread	Pressure port B and suction port S in axial direction	—	—	—	—	—	—	—	11
			—	—	—	●	—	—	—	41
		Pressure port B and suction port S at side	●	●	●	●	●	●	●	12
			—	—	—	● ¹⁾	—	—	—	42
	SAE port flange, UNC fastening thread	Pressure port B and suction port S in axial direction	—	—	—	—	—	—	—	61
			—	—	—	●	—	—	—	91
		Pressure port B and suction port S at side	●	●	●	●	●	●	●	62
			—	—	—	● ²⁾	—	—	—	92

1) 42 end cap uses 12

2) 92 end cap uses 62



Model Code

	C	A	B		I	K		M	N	P	R	S	X		Z
HA10V(S)	O			/	3 1		-							-	

Through drive

			18	28	45	71	100	110	140	
Without through drive			●	●	●	●	●	●	●	N00
ISO 3019-2 Splined shaft for ANSI B92.1 Parallel keyed shaft for ISO 3019-2										
80-2	3/4" 11T 16/32DP	HA10VSO 18(shaft S or R)	—	●	●	●	○	○	○	KB2
	Parallel keyed shaft Ø18	HA10VSO 18(shaft P)	—	●	●	●	●	●	●	K51
100-2	7/8" 13T 16/32DP	HA10VSO 28(shaft S or R)	—	●	●	●	●	●	●	KB3
	Parallel keyed shaft Ø22	HA10VSO 28(shaft P)	—	●	●	●	●	●	●	K25
	1" 15T 16/32DP	HA10VSO 45(shaft S or R)	—	—	●	●	●	●	●	KB4
	Parallel keyed shaft Ø25	HA10VSO 45(shaft P)	—	—	●	●	●	●	●	K26
125-2	1 1/4" 14T 12/24DP	HA10VSO 71(shaft S or R)	—	—	—	●	●	●	●	KB5
	Parallel keyed shaft Ø32	HA10VSO 71(shaft P)	—	—	—	●	●	●	●	K27
	1 1/2" 17T 12/24DP	HA10VSO 100(shaft S)	—	—	—	—	●	●	●	KB6
	Parallel keyed shaft Ø40	HA10VSO 100(shaft P)	—	—	—	—	○	○	○	K37
180-4	1 3/4" 13T 8/16DP	HA10VSO 140(shaft S)	—	—	—	—	—	—	●	KB7
	Parallel keyed shaft Ø45	HA10VSO 140(shaft P)	—	—	—	—	—	—	○	K59
S SAE J744 Splined shaft for ANSI B92.1 Parallel keyed shaft for SAE J744										
82-2(A)	5/8" 9T 16/32DP(radial seal)		—	●	●	●	●	●	●	K01
	5/8" 9T 16/32DP(axial seal)		—	●	●	●	●	●	●	K01M
	3/4" 11T 16/32DP	HA10VSO 18(shaft S)	—	●	●	●	●	●	●	K52
	Parallel keyed shaft 19-1(SAE A-B)	HA10VSO 18(shaft K)	—	○	○	○	○	○	○	K40
101-2 (B)	7/8" 13T 16/32DP(radial seal)	HA10VSO 28(shaft S)	—	●	●	●	●	●	●	K02
	7/8" 13T 16/32DP(axial seal)	HA10VSO 28(shaft S)	—	●	●	●	●	●	●	K68
	Parallel keyed shaft 22-1(SAE B)	HA10VSO 28(shaft K)	—	○	○	○	○	○	○	K03
	1" 15T 16/32DP	HA10VSO 45(shaft S)	—	●	●	●	●	●	●	K04
	Parallel keyed shaft 25-1(SAE B-B)	HA10VSO 45(shaft K)	—	—	○	○	○	○	○	K05
127-2 (C)	1 1/4" 14T 12/24DP	HA10VSO 71(shaft S)	—	—	—	●	●	●	○	K07
	Parallel keyed shaft 32-1(SAE C)	HA10VSO 71(shaft K)	—	—	—	○	○	○	○	K08
	1 1/2" 17T 12/24DP	HA10VSO 100(shaft S)	—	—	—	—	●	●	●	K24
	Parallel keyed shaft 44-1(SAE C-C)	HA10VSO 100(shaft K)	—	—	—	—	○	○	○	K38
152-4 (D)	1 3/4" 13T 8/16DP	HA10VSO 140(shaft S)	—	—	—	—	—	—	●	K17
	Parallel keyed shaft 44-1(SAE D)	HA10VSO 140(shaft K)	—	—	—	—	—	—	○	K21



> Model Code

	c	A	B		I	K		M	N	P	R	S	X		Z
HA10V(S)	O			/	3 1		-							-	

Solenoid connector

X		18	28	45	71	100	110	140	
	Without connector (without solenoid, only for hydraulic control, (without code)	●	●	●	●	●	●	○	
	DEUTSCH DT04-2P; 2-pin plastic connector, without diode suppressor (for electric control)	●	●	●	●	●	●	○	P
	3-pin square connector	●	●	●	●	●	●	○	H
	DEUTSCH DT04-2P with cable	●	●	●	●	●	●	○	T

Special configuration

Z		18	28	45	71	100	110	140	
	Without special configuration (without code)	●	●	●	●	●	●	●	
	Special configuration	○	○	○	○	○	○	○	***

- Available
- On request
- Not available
- Recommended model

Combination pump: If two HA10VSO pumps are combined at our plant, connect their models with a "+".
 Example: HA10VSO71DR/31R-PSA12KB4 + HA10VSO45DR/31R-PSA12N00



> Structure

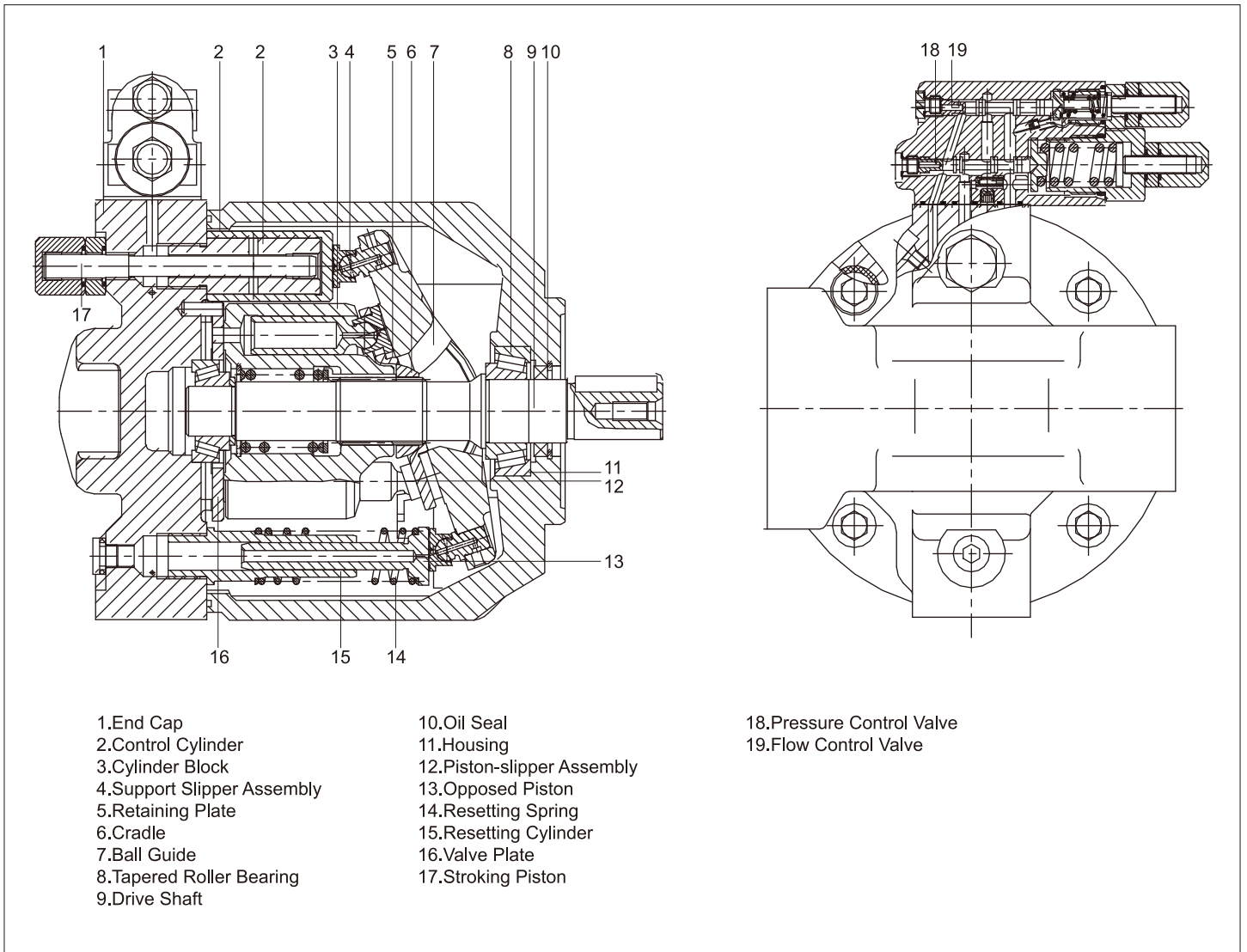



> Hydraulic Fluid

Mineral oil

> Working Viscosity

In order for the optimum efficiency and service life, it is recommended to select the working viscosity at working temperature within the range below:

$$V_{opt} = \text{optimal working viscosity } 16...36 \text{ mm}^2/\text{s}$$

It is subject to the reservoir temperature of an open circuit.

> Limit Viscosity

Limit viscosity:

$$V_{min} = 10 \text{ mm}^2/\text{s}$$

Short-term operation, at permissible maximum leakage temperature of 90 °C

$$V_{max} = 1000 \text{ mm}^2/\text{s}$$

Short-term operation, cold start

> Temperature Range

$$t_{min} = -25^\circ\text{C}$$

$$t_{max} = 90^\circ\text{C}$$

> Selection Diagram

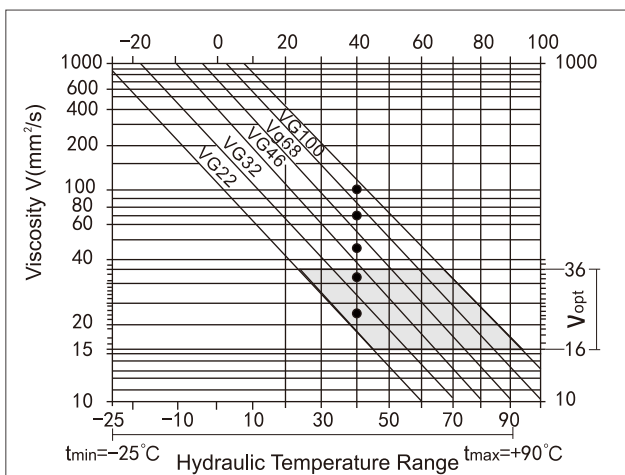

> Instructions on Selection of Hydraulic Fluid

To select the correct hydraulic fluid, we must know the relationship between the fluid working temperature in the reservoir (open circuit) and the ambient temperature.

The hydraulic fluid should be so selected that the working viscosity in the working range is within the optimum range (V_{opt} , the shaded area on the selection diagram). The higher viscosity is recommended under the same conditions.

For example:

At an ambient temperature of X °C, the working temperature of the circuit is 60 °C. The viscosity within the optimum range (V_{opt} , shaded area) is VG46 or VG68 and the latter should be selected.

Note:

The leakage (case drain) temperature depends on the pressure and speed of the pump, and it is always higher than the reservoir temperature. However, the maximum temperature at any point within the system should not exceed 90 °C.

> Filtration

Finer filtration improves the cleanliness level of the hydraulic fluid, thus increasing the service life of the axial piston unit. To ensure normal operation of the axial piston unit, a cleanliness level of at:

NAS 1638,9

ISO/DIS 4406 18/15

Please contact us if the above cleanliness level cannot be reached.

> Mechanical Displacement Limiter

The mechanical displacement limiter is available for 12/62N00 series piston pumps without through drive and it realizes free adjustment of maximum displacement between 100% ↔ 50%.

> Working Pressure Range

Input

Absolute pressure at port S

P_{abs min} _____ 0.8bar

P_{abs max} _____ 30bar

It determines the decrease in displacement with increase in inlet pressure P_{abs} at port S or rotational speed.

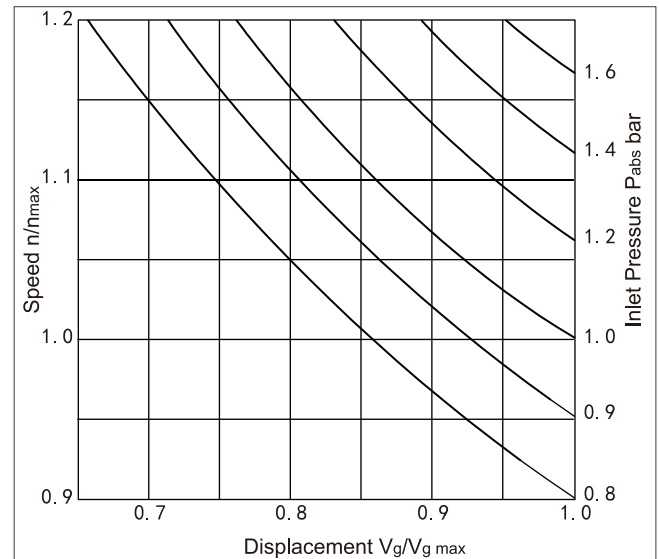

Output

Absolute pressure at port B

P_n _____ 280bar

P_{max} _____ 350bar

The pressure may reach 315 bar at 10% load time during intermittent operation.

> Case Drain Pressure

Maximum permissible pressure at drain port (L, L1)

Maximum 0.5 bar higher than inlet pressure at port S

No higher than 2 bar absolute pressure

> Flow Direction

From port S to B



► Technical Data

Size	Unit		18	28	45	71	100	110	140	
Displacement	$V_{g\ max}$	mL/r	18	28	45	71	100	110	140	
Speed ¹⁾	n_{omax}	r/min	3300	3000	2600	2200	2000	2000	1800	
	Max. speed (continuous) n_{ζ} at increase in inlet pressure P_{abs} and $V_g < V_{g\ max}$	n_{omax}	r/min	3900	3600	3100	2600	2400	2400	2100
Flow	At n_{omax}	$q_{v\ omax}$	L/min	59.4	84	117	156	200	220	252
	At $n_{\zeta}=1500\ min^{-1}$		L/min	27	42	68	107	150	165	210
Power $\Delta P=28\ MPa$	At n_{omax}	P_{omax}	KW	27.7	39	55	73	93	106	118
	At $n_{\zeta}=1500\ min^{-1}$		KW	12.6	20	32	50	70	77	98
Max. torque at $V_{g\ max}(\Delta p=28\ MPa)$	T_{max}	Nm	80.1	125	200	316	445	507	623	
Max. torque at $V_{g\ max}(\Delta p=10\ MPa)$	T	Nm	28.6	45	72	113	159	176	223	
Moment of inertia of drive shaft	J	kgm^2	0.00093	0.0017	0.0033	0.0083	0.0167	0.0167	0.0242	
Case volume	L		0.4	0.7	1.0	1.6	2.2	2.2	3.0	
Weight	m	kg	12	15	21	33	45	45	60	

1) The above data is valid only when the inlet pressure at port S is 0.1 MPa absolute pressure. The speed may increase as the displacement decreases or the inlet pressure increases.

► Specification Calculation

Flow	$q_v = \frac{V_g \cdot n \cdot \eta_v}{1000}$	[L/min]	V_g = Displacement, mL/r
			Δp = Differential pressure, MPa
Torque	$T = \frac{V_g \cdot \Delta p}{2 \cdot \pi \cdot \eta_{mh}}$	[Nm]	n = Speed, rpm
			η_v = Volumetric efficiency
Power	$P = \frac{2 \pi \cdot T \cdot n}{60000} = \frac{q_v \cdot \Delta p}{60 \cdot \eta_t}$	[KW]	η_{mh} = Mechanical-hydraulic efficiency
			η_t = Total efficiency



> Characteristic Curve

Measured indoor without echo

Distance from sound measuring device to the pump=1m

Max. measuring error $\pm 2\text{dB(A)}$ (working medium: hydraulic fluid ISO VG46 DIN 51519, $t=50^\circ\text{C}$)

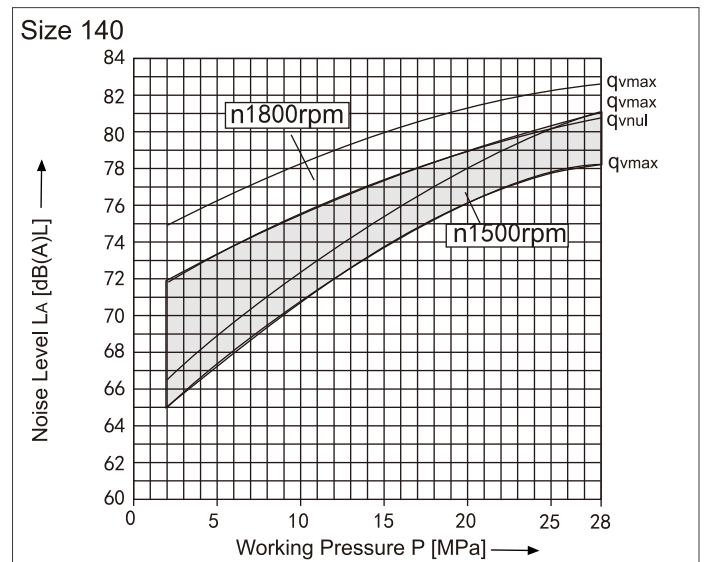
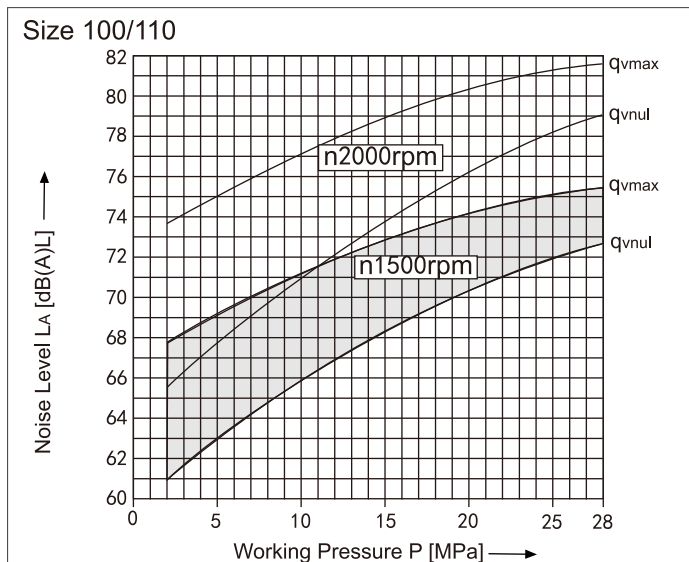
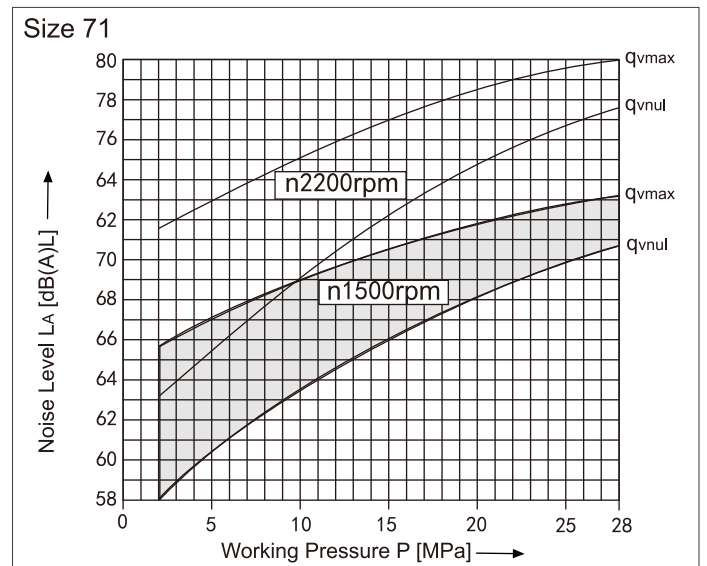
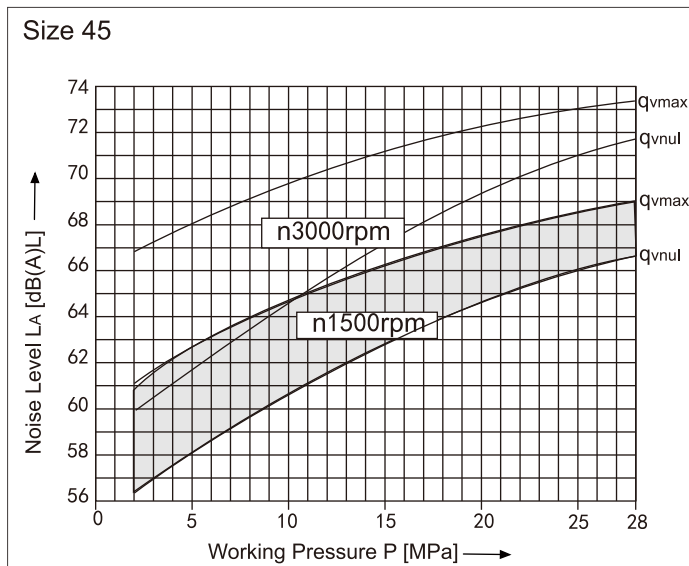
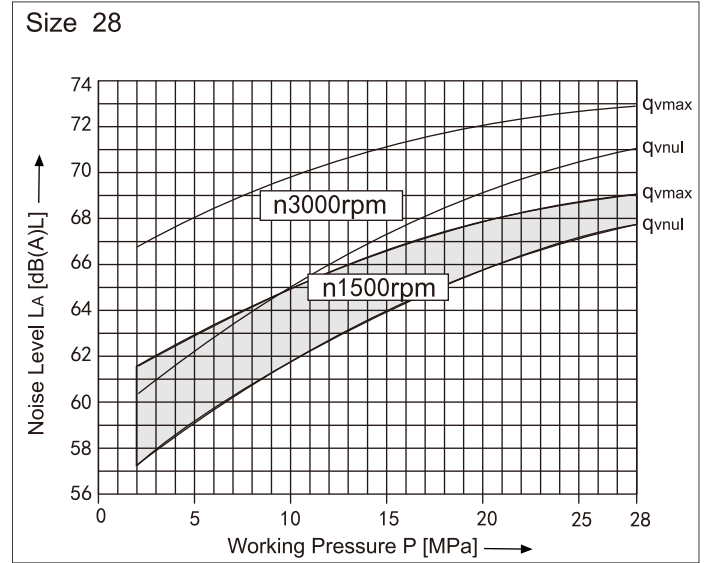
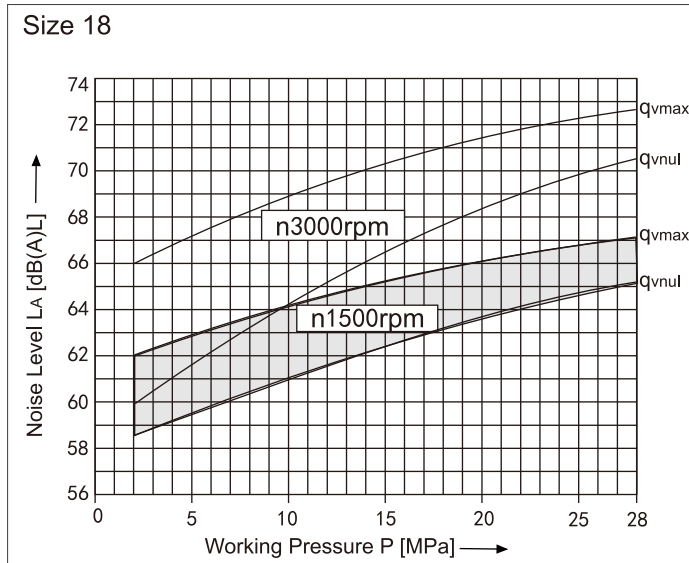



Drive Power and Flow

Working medium: hydraulic fluid ISO VG46 DIN 51519, $t=50^{\circ}\text{C}$

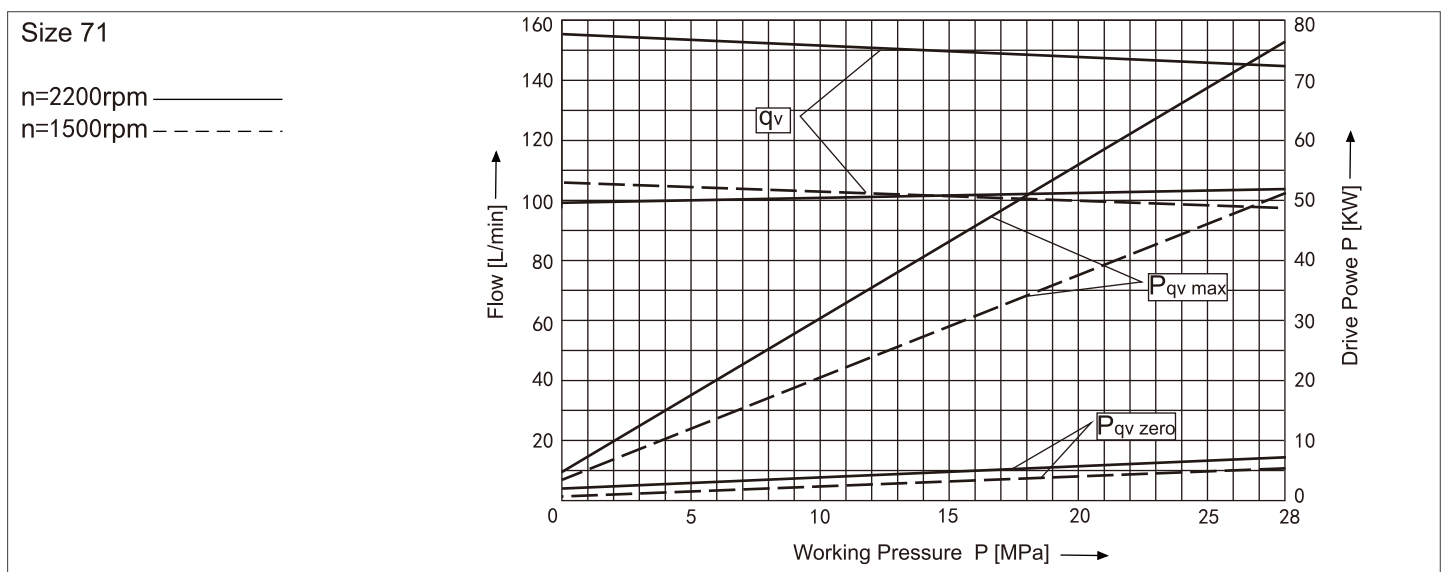
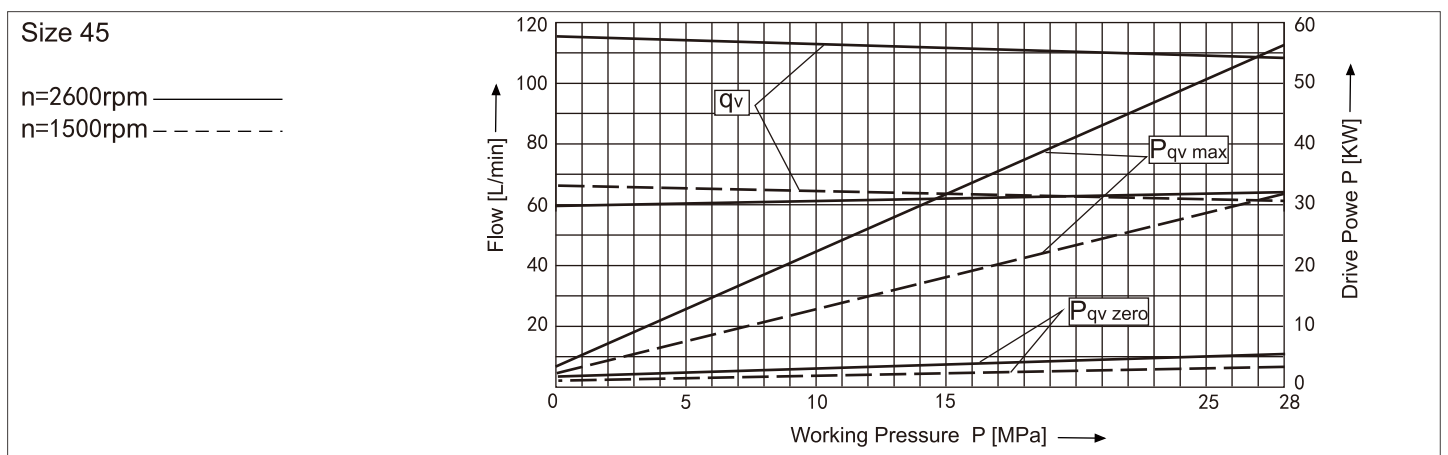
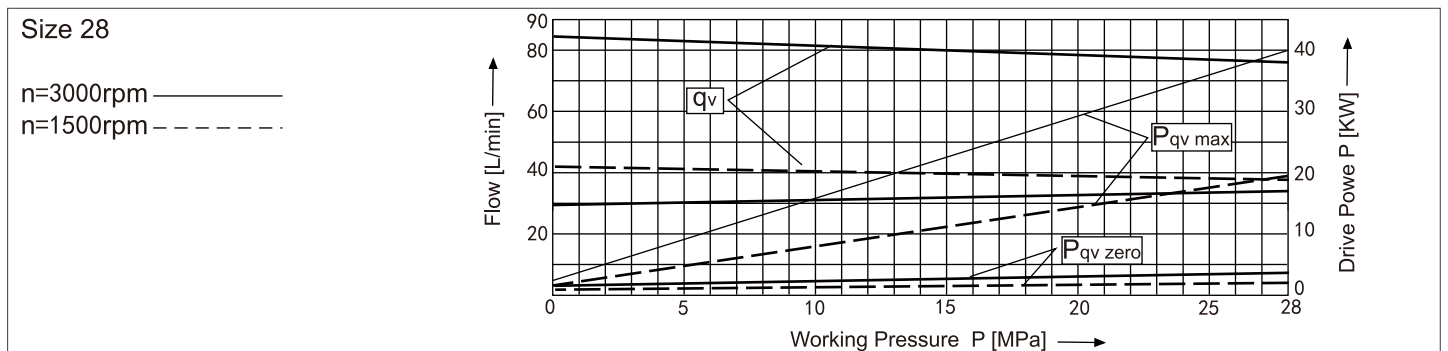
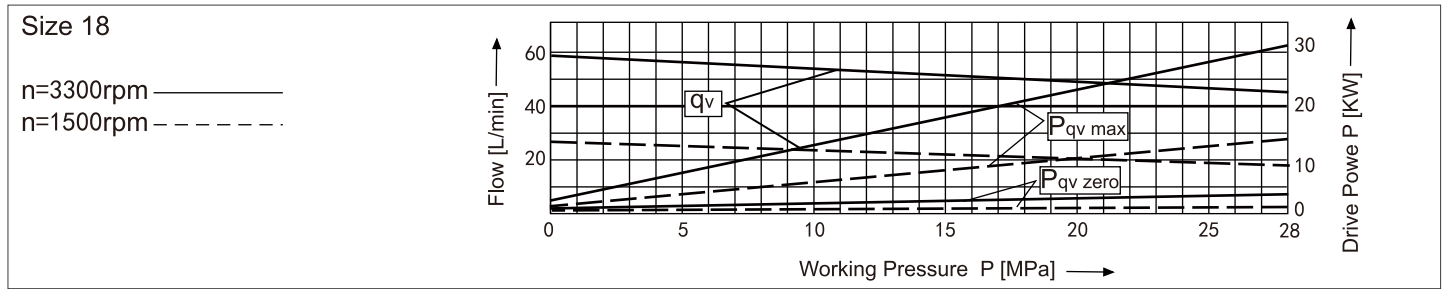



► Drive Power and Flow

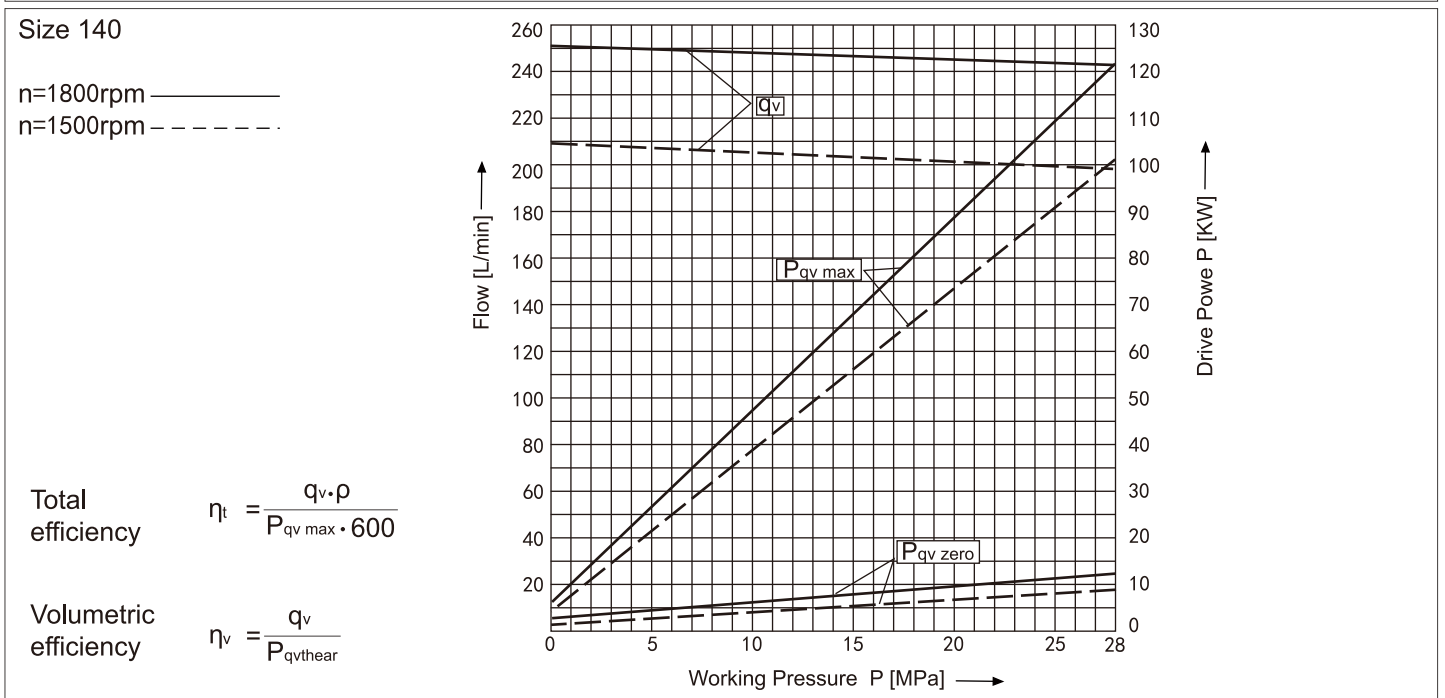
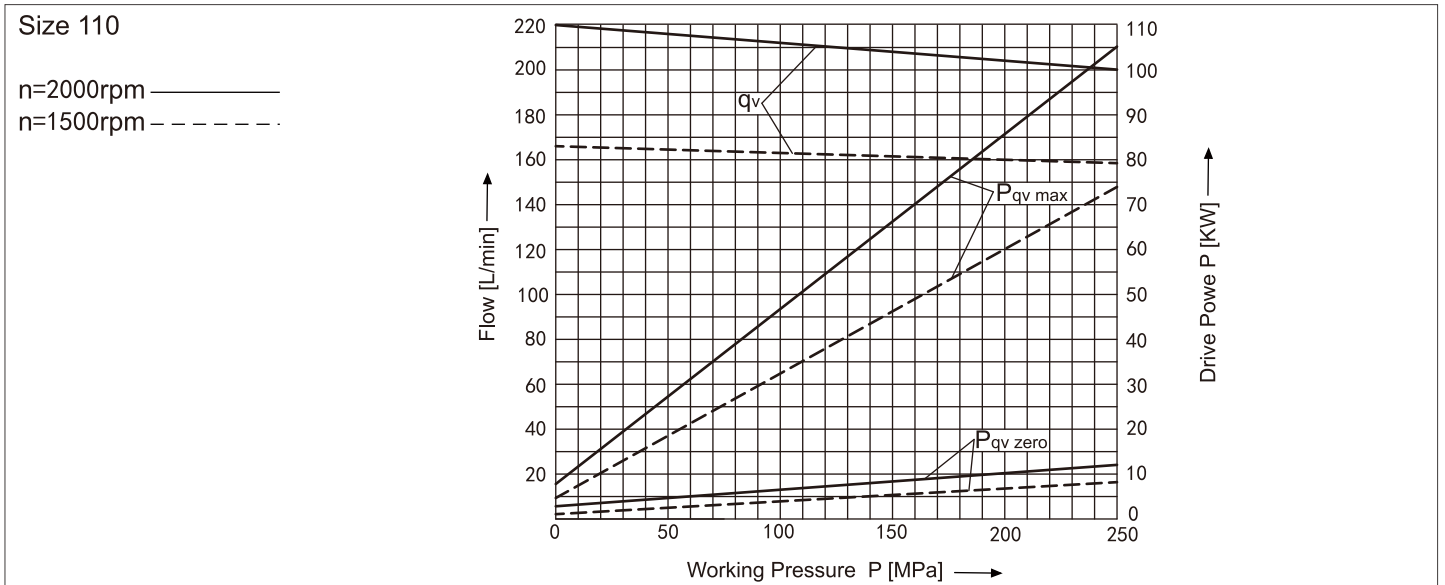
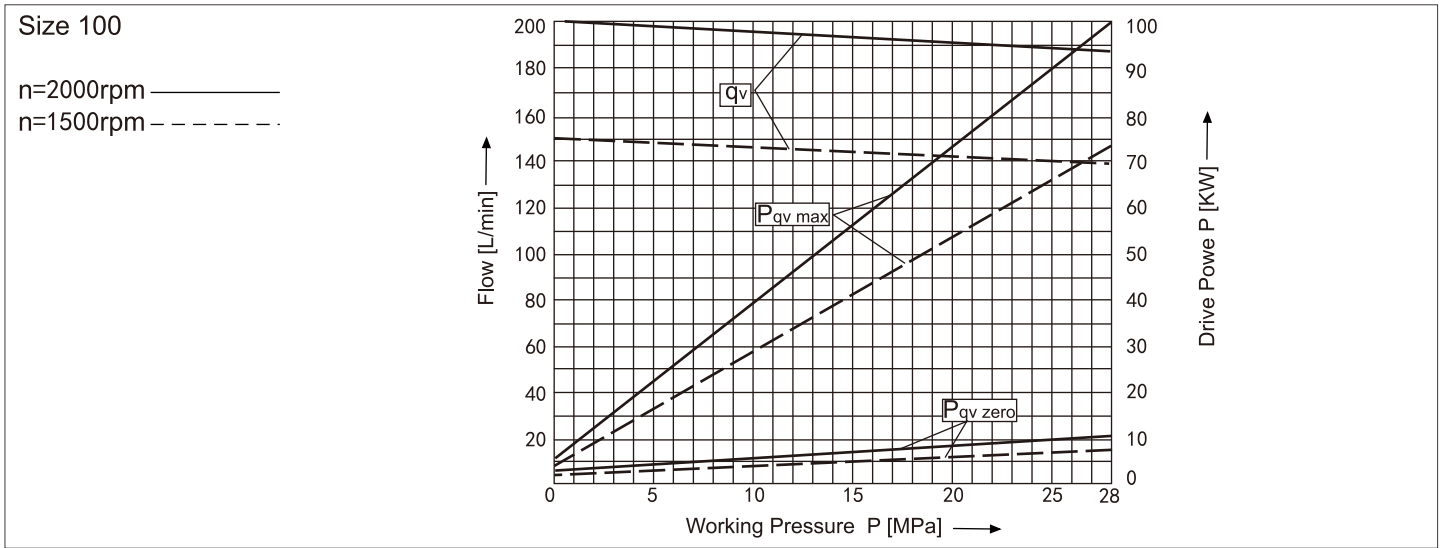



► Installation Dimensions

Size 18
N00
Without control valve

Shaft P

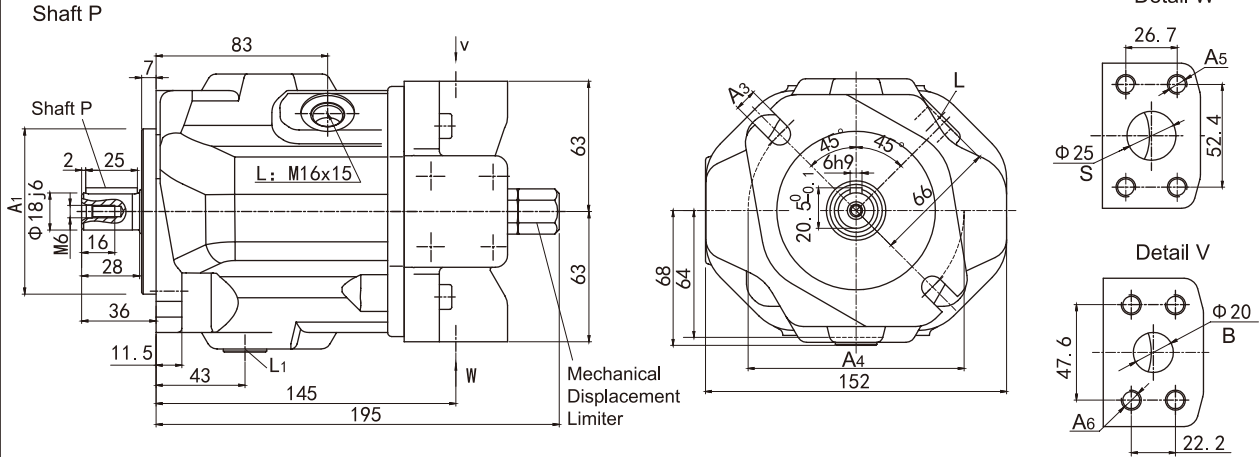

Shaft S

Splined shaft
ANSI B92.1-1976
11T 16/32DP 30°

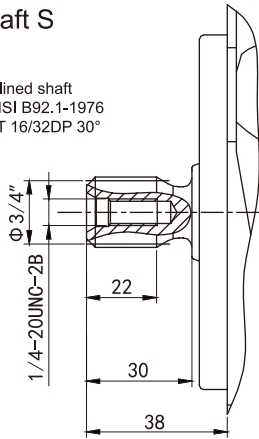

Shaft U

Splined shaft
ANSI B92.1-1976
9T 16/32DP 30°

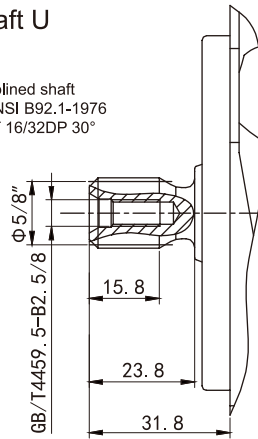

Shaft K

No. 12-24UNC-2B

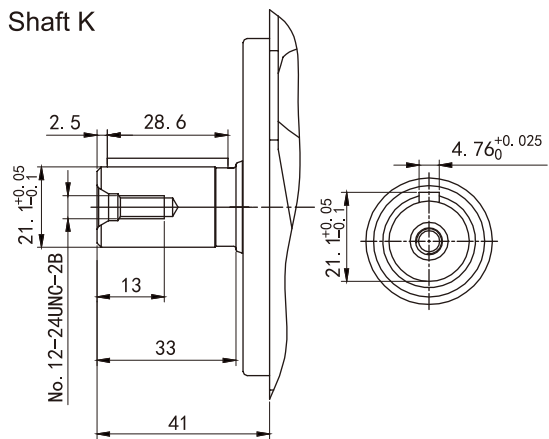

B _____ pressure port SAE3/4 " (standard pressure range)

S _____ inlet port SAE1 " (standard pressure range)

L/L₁ _____ case drain port(L₁ plugged before delivery)

Size	A ₁	A ₂	A ₃	A ₄	A ₅	A ₆	Port L/L ₁
18iso	$\Phi 80h8$	7	11	$\Phi 109$	4-M10, 17deep	4-M10, 17deep	M16x1.5
18SAE	$\Phi 82.55h8$	6.3	11	$\Phi 106.4$	4-3/8-16UNC-2B, 20deep	4-3/8-16UNC-2B, 20deep	9/16-18UNF-2B



► Installation Dimensions

Size 28
N00
Without control valve

Shaft P

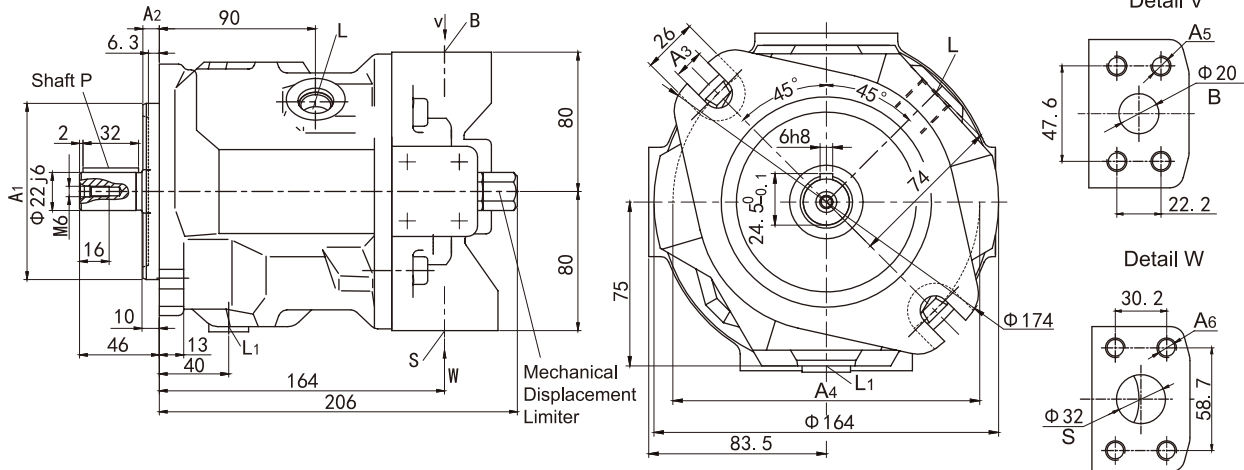

Shaft S

Splined shaft 22-4;
(SAE B)SAE J744 OCT 83
13T 16/32DP 30°

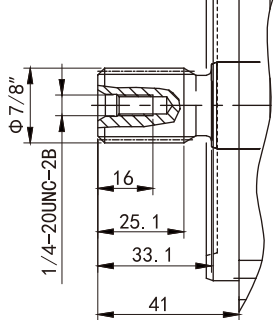

Shaft R

Splined shaft 22-4;
(SAE B)SAE J744 OCT 83
13T 16/32DP 30°

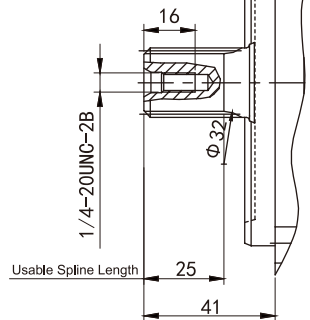

Shaft K

Splined shaft 22-1;
(SAE B)
ISO 3019-1

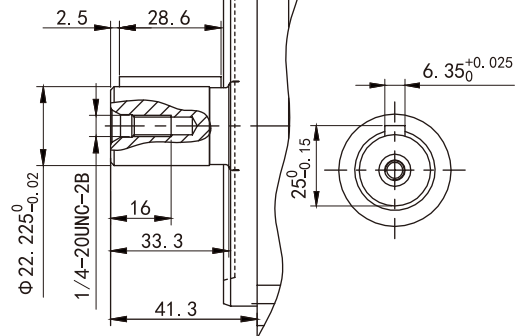

B _____ pressure port SAE3/4 " (standard pressure range)

S _____ inlet port SAE1 1/4 " (standard pressure range)

L/L1 _____ case drain port(L1 plugged before delivery)

Size	A1	A2	A3	A4	A5	A6	Port L/L1
28ISO	Φ 100h8	9	14	Φ 140	4-M10, 17deep	4-M10, 17deep	M18x1.5
28SAE	Φ 101.6h8	9.5	14	Φ 146	4-3/8-16UNC-2B, 18deep	4-7/16-14UNC-2B, 24deep	3/4-16UNF-2B



Installation Dimensions

Size 45
N00
Without control valve

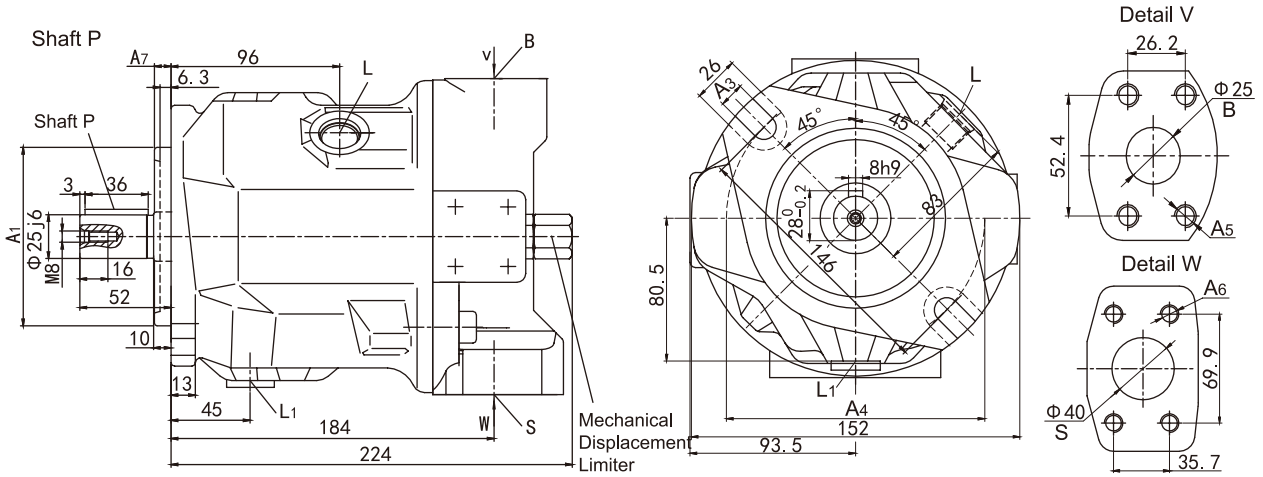

Shaft S

Splined shaft 25-4;
(SAE B-B)SAE J744 OCT 83
15T 16/32DP 30°

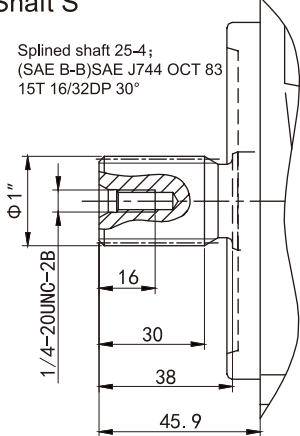

Shaft R

Splined shaft 25-4;
(SAE B-B)SAE J744 OCT 83
15T 16/32DP 30°

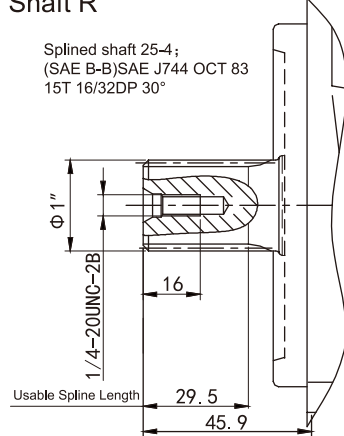

Shaft K

Splined shaft 25-1;
(SAE B-B)
ISO 3019-1

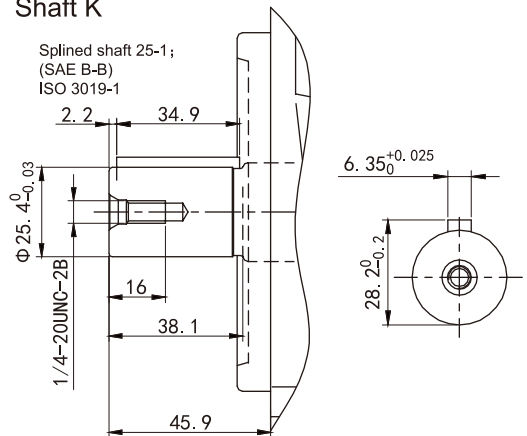

Shaft U

Splined shaft 25-4;
(SAE B)SAE J744 OCT 83
13T 16/32DP 30°

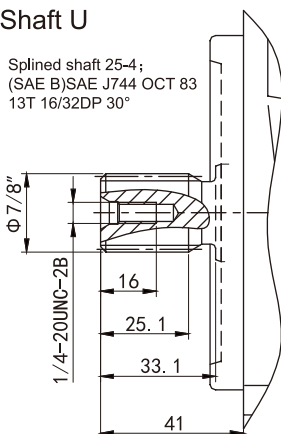

B _____ pressure port SAE 3/4 " (standard pressure range)
S _____ inlet port SAE 1 1 / 4 " (standard pressure range)
L/L1 _____ case drain port(L1 plugged before delivery)

Size	A1	A2	A3	A4	A5	A6	Port L/L1
45ISO	Φ 100h8	9	14	Φ 140	4-M10, 17deep	4-M12, 20deep	M22x1.5
45SAE	Φ 101.6h8	9.5	14	Φ 146	4-3/8-16UNC-2B, 18deep	4-1/2-13UNC-2B, 22deep	7/8-14UNF-2B



► Installation Dimensions

Size 71
12/62 N00
Without control valve

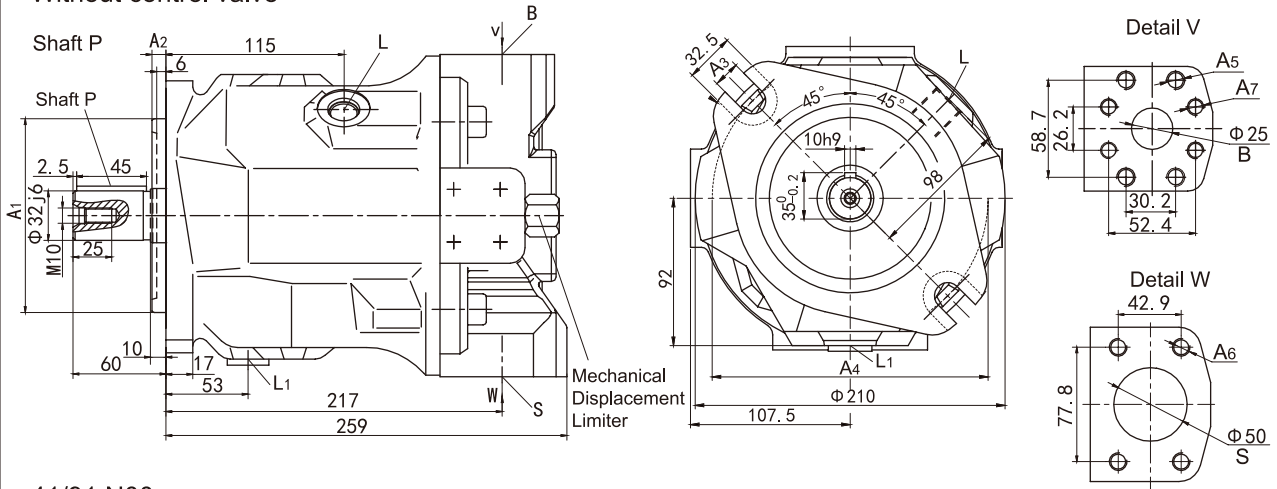

41/91 N00
Without control valve

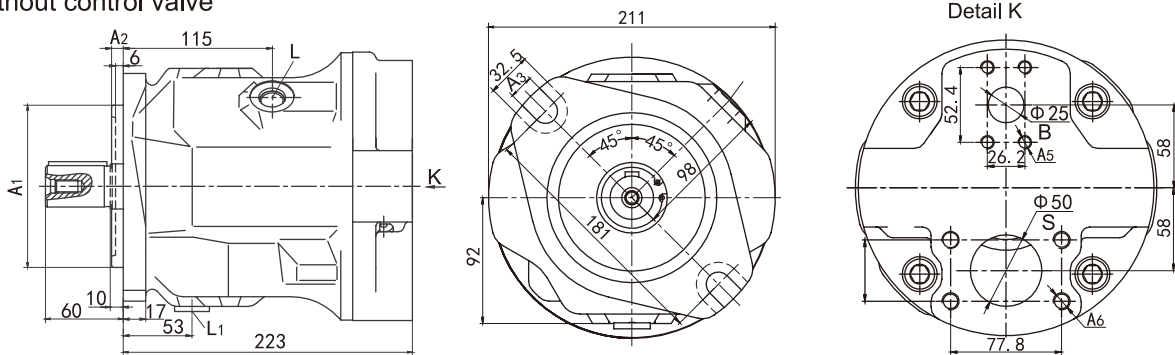

Shaft S

Splined shaft 32-4;
(SAE C)SAE J744 OCT 83
14T 12/24DP 30°

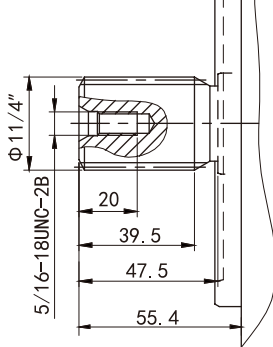

Shaft R

Splined shaft 32-4;
(SAE C)SAE J744 OCT 83
14T 12/24DP 30°

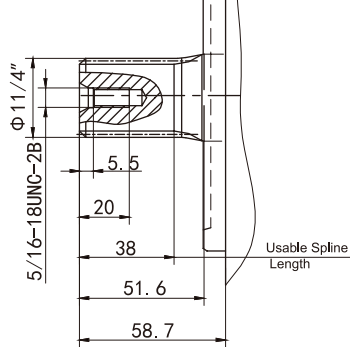

Shaft K

Splined shaft 32-1;
(SAE C)
ISO 3019-1

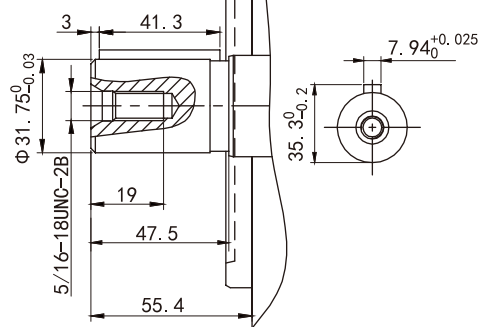

B _____ pressure port SAE3/4 " (standard pressure range)

S _____ inlet port SAE1 1 / 4 " (standard pressure range)

L/L1 _____ case drain port(L1 plugged before delivery)

Size	A1	A2	A3	A4	A5 (A7)	A6	Port L/L1
71iso	Φ 125h8	9	18	Φ 180	8-M10, 20deep	4-M12, 20deep	M22x1.5
71SAE	Φ 127h8	12.7	18	Φ 181	4-3/8-16UNC-2B, 18deep 4-7/16-14UNC-2B, 24deep	4-1/2-13UNC-2B, 22deep	7/8-14UNF-2B



► Installation Dimensions

Size 100/110
N00
Without control valve

Shaft P

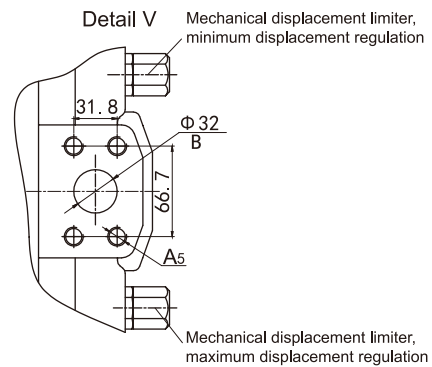
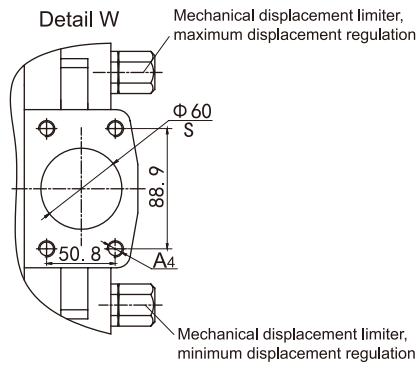
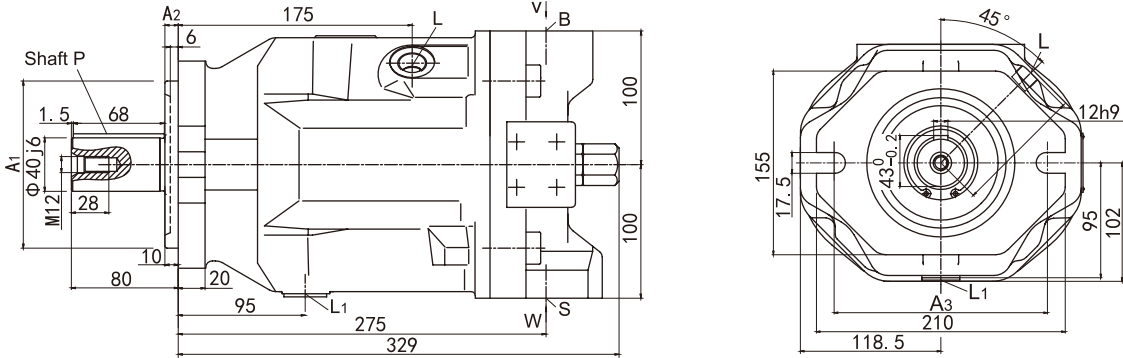

Shaft S

Splined shaft 38-4;
(SAE C-C)SAE J744 OCT 83
17T 12/24DP 30°

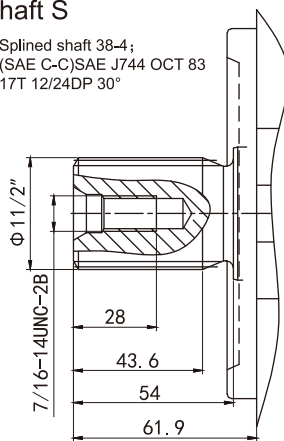

Shaft U

Splined shaft 38-4;
(SAE C)SAE J744 OCT 83
14T 12/24DP 30°

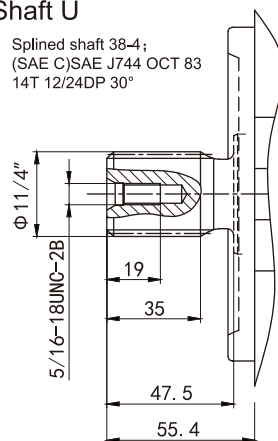

Shaft K

Splined shaft 38-1;
(SAE C-C)
ISO 3019-1

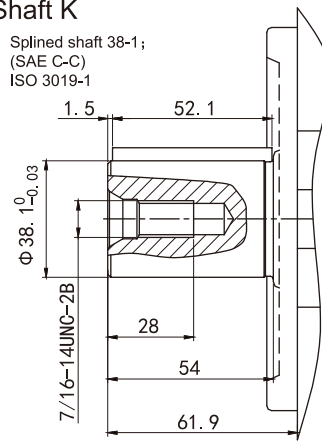

B _____ pressure port SAE1 1/4 " (standard pressure range)

S _____ inlet port SAE2 1/2 " (standard pressure range)

L/L1 _____ case drain port(L1 plugged before delivery)

Size	A1	A2	A3	A4	A5	Port L/L1
100/110ISO	Φ 125h8	9	Φ 180	4-M12, 17deep	4-M14, 19deep	M27x2
100/110SAE	Φ 127h8	12.7	Φ 181	4-1/2-13UNC-2B, 19deep	4-1/2-13UNC-2B, 22deep	11/16-12UNF-2B



► Installation Dimensions

Size 140
N00
Without control valve

Shaft P

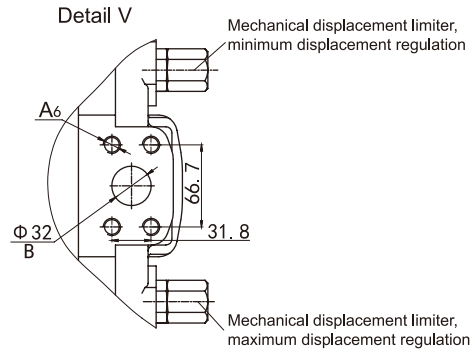
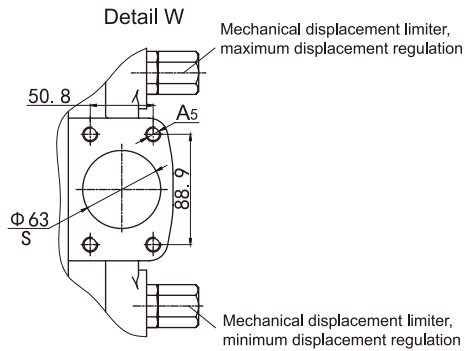
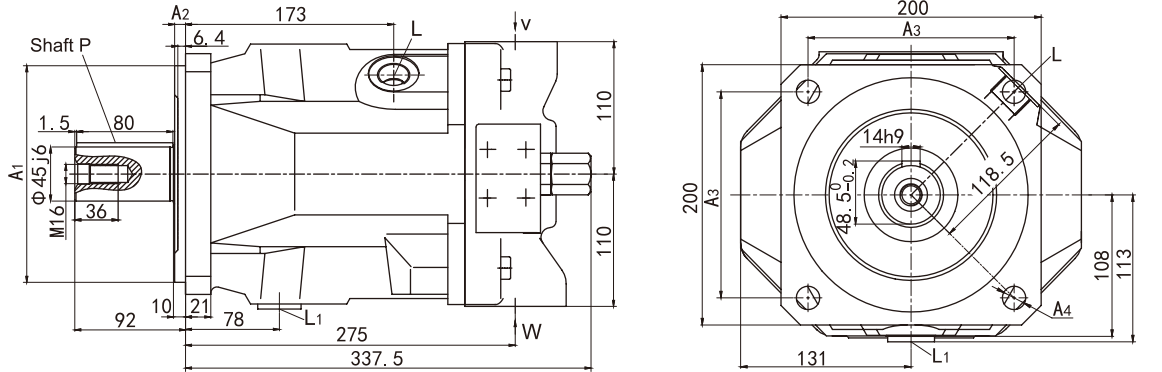

Shaft S

Splined shaft 44-4;
(SAE D)SAE J744 OCT 83
13T 8/16DP 30°

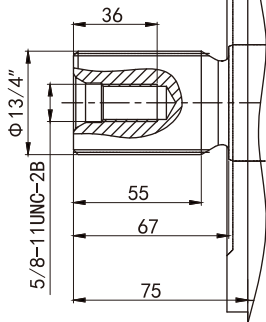

Shaft K

Splined shaft 44-1;
(SAE D)
ISO 3019-1

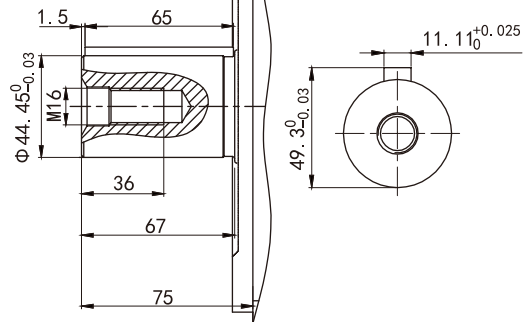

B _____ pressure port SAE1 1/4 " (standard pressure range)

S _____ inlet port SAE2 1/2 " (standard pressure range)

L/L1 _____ case drain port(L1 plugged before delivery)

Size	A1	A2	A3	A4	A5 (A7)	A6	Port L/L1
140ISO	Φ 180h8	9	158.4	4-Φ 18	4-M12, 17deep	4-M14, 19deep	M27x2
140SAE	Φ 152.4h8	12.7	161.6	4-Φ 20	4-1/2-13UNC-2B, 24deep	4-1/2-13UNC-2B, 19deep	1 1/16-12UNF-2B



DR-Pressure Control

The pressure controller is used to maintain a constant pressure of the hydraulic system within the control range. As the pump supplies only as much hydraulic fluid as required by the system, the pressure may be continually regulated by the control valve.

Static operating curve (n₁=1500rpm, t_{oil}=50°C)

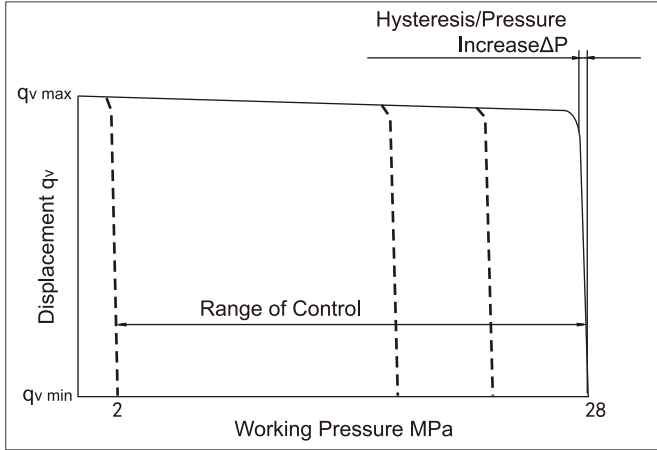

Dynamic operating curve

This curve indicates the average measurement in test conditions with the pump installed in the tank.

Working conditions: n=1500rpm
t_{oil}=50°C

Setting of main pressure relief valve 35MPa

Pump loaded with pressure relief valve which is 1m from outlet flange of the pump.

Load step realized by suddenly switching on and off the pressure line.

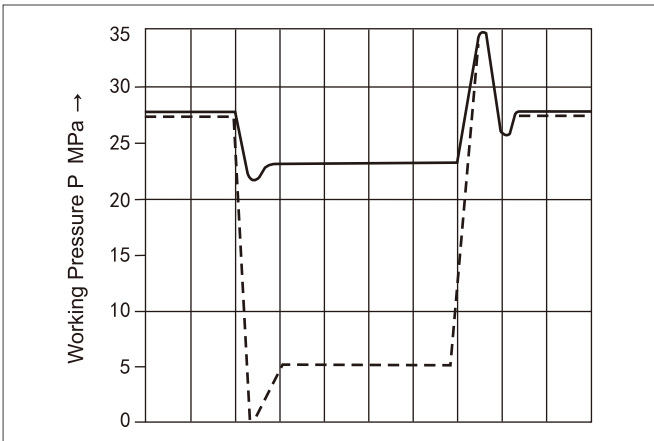

Dynamic flow control curve

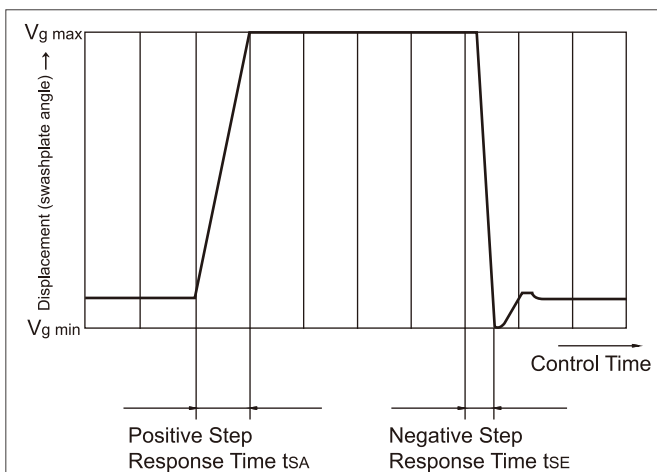

Controller data

Hysteresis and repeatability Δp _____ max. 0.3MPa

Maximum pressure increase

Size	18	28	45	71	100	110	140
Δp MPa	0.4	0.4	0.6	0.8	1.0	1.0	1.2

Pilot fluid consumption _____ max.3L/min

Controller time

Size	tsA(ms) at 5MPa	tsA(ms) at 22MPa	tsA(ms) at 28MPa
18	50	20	20
28	60	30	20
45	80	40	20
71	100	50	25
100	125	90	30
110	125	90	30
140	130	110	30

Circuit diagram

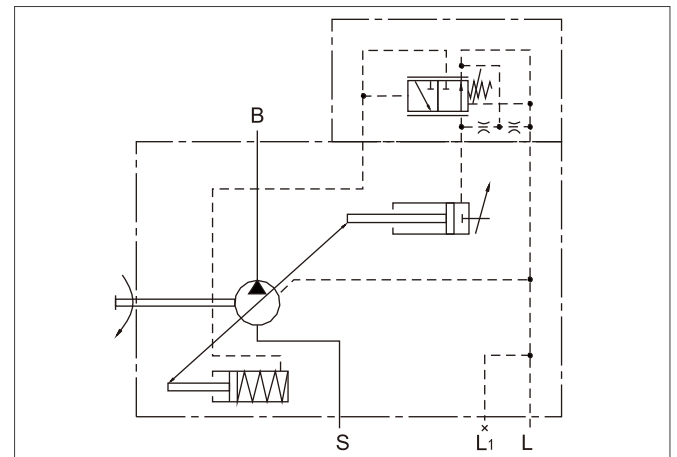

Ports

B _____ pressure port

S _____ inlet port

L/L1 _____ case drain port (L1 plugged)



DRG-Pressure/Remotely Control

DR functions and device

A pressure relief valve may be connected to port X for remote control and the valve is not within the scope of delivery of DRG controller. The standard differential pressure of the control valve is 2MPa and the required pilot control flow is 1.5L/min. For other settings (within the range of 1 to 2 MPa), please specify when ordering.

Static operating curve($n_1=1500\text{rpm}$, $t_{oil}=50^\circ\text{C}$)

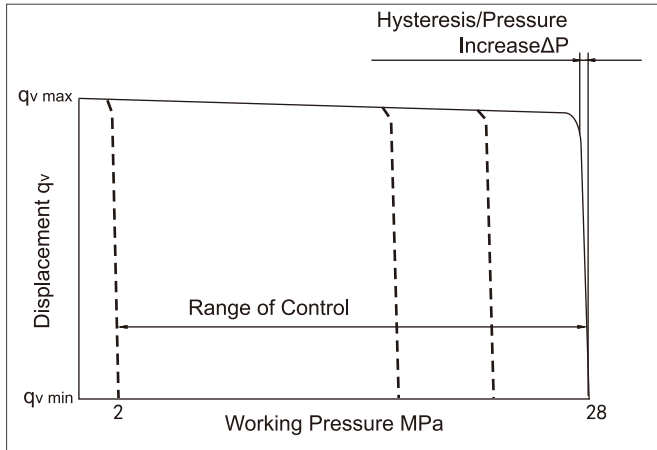

Controller data

Hysteresis Δp _____ max.0.3MPa

Maximum pressure increase

Size	18	28	45	71	100	110	140
Δp MPa	0.4	0.4	0.6	0.8	1.0	1.0	1.2

Pilot fluid consumption _____ approx.4.5L/min

Circuit diagram(Size 18-110)

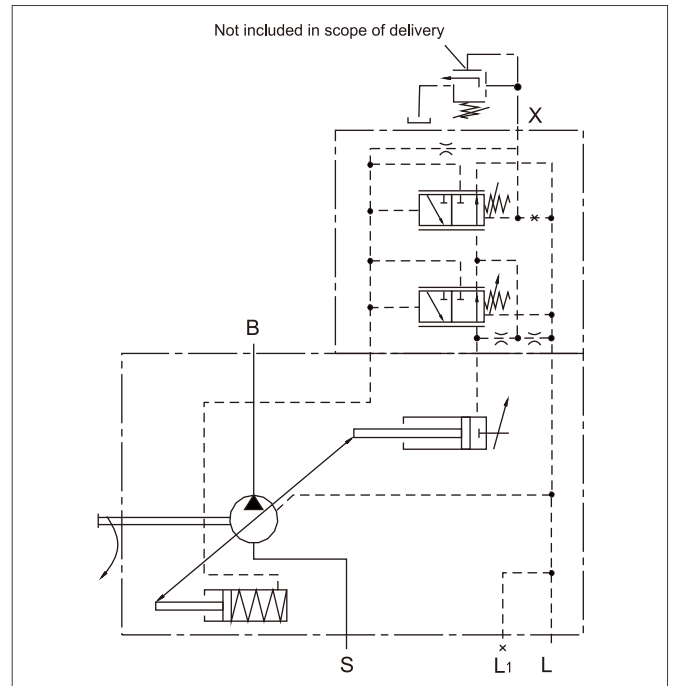

Circuit diagram(Size 140)

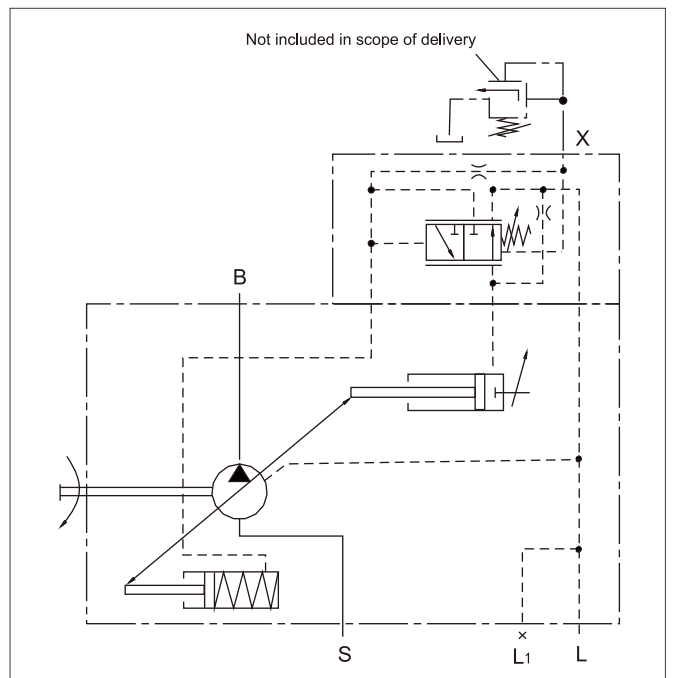

Ports

- B _____ pressure port
- S _____ inlet port
- L/L1 _____ case drain port (L1 plugged)
- X _____ pilot pressure port



ED-Electro-proportional Remote Pressure Control

The maximum output pressure of the pump depends on the current of the solenoid.

The pump displacement increases to increase the flow and satisfy system requirement if the pump pressure falls below the set pressure. When it reaches the set pressure, the pump will attain the desired flow by regulating its displacement.

The maximum system pressure may be continually adjusted by changing the solenoid current. In reversely proportional control, the pump is in standby state at maximum solenoid current and it has the maximum output pressure at zero current (fail safe function for fan drive). The adjustable hydraulic-mechanical setting at the maximum pressure takes precedence over the current signal.

The maximum output pressure for hydraulic-mechanical setting takes priority over electric signal setting.

Model	ED71	ED72
Working voltage	12V±20%	24V±20%
Start of pressure control p_{max}	100mA	50mA
End of pressure contro p_{min}	1200mA	600mA
Nominal resistance at 20 °C(R_{20})	5.5Ω	22.7Ω
Limit current at U_{max}	1.54A	0.77A
Maximum duty cycle	100%	
Temperature range	-20°C to +115°C	
Dither frequency	100-200Hz	
Solenoid material grade	H($T_{max}=180^{\circ}C$)	

Resistance calculation equation

$$\text{at } T > 20^{\circ}C \quad R_w = \frac{R_{20} \times (235 + T)}{255}$$

Note: Take protective actions as the valve is very hot during operation and immediately after stop!

Static current - pressure characteristic (inversely proportional control)

(measured with pump at zero stroke)

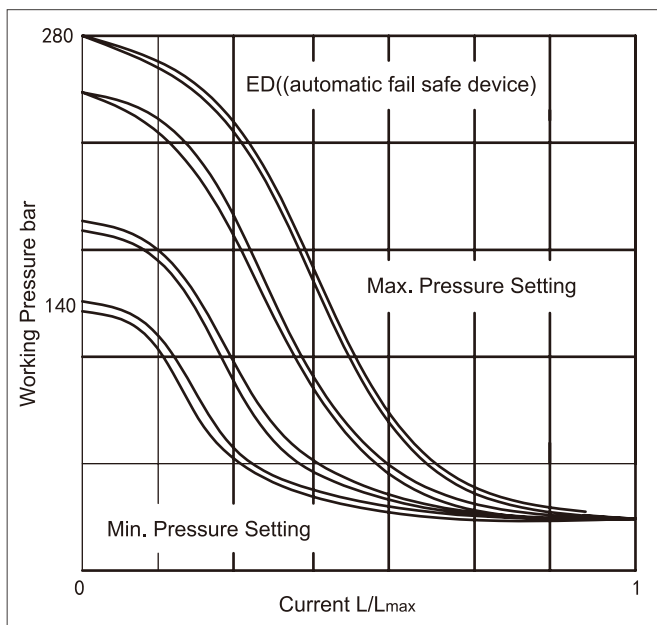

Hysteresis static current-pressure characteristic _____ < 3bar

Static operating curve($n=1500\text{min}^{-1}$, $t_{oil}=50^{\circ}C$)

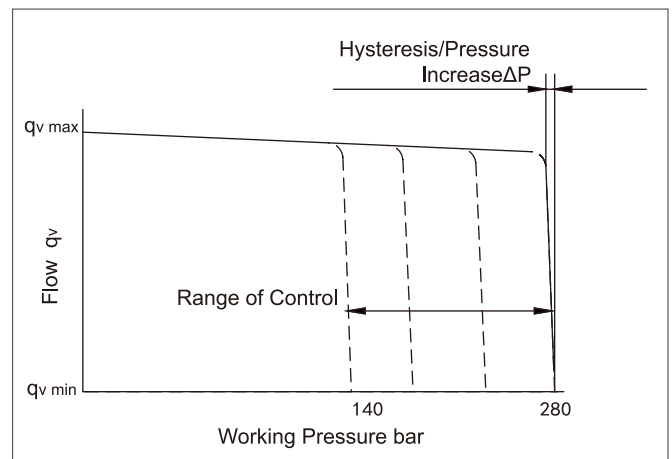

Controller

Standby standard pressure setting 20bar(range 14-22bar)

Hysteresis/pressure increase Δp _____ < 4bar

Circuit diagram

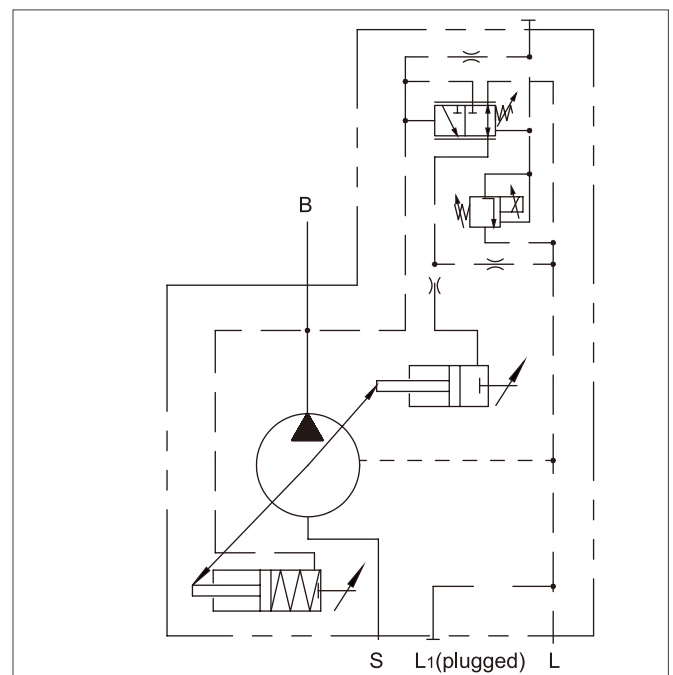

Ports

B _____ pressure port

S _____ inlet port

L/L1 _____ case drain port (L1 plugged)

Pilot fluid consumption _____ 3-4.5L/min



► DFR/DFR1-Pressure/Flow Control

In addition to pressure controller functions, it can also change pump flow by the aid of the differential pressure of a load (e.g. a small hole). The pump supplies only the actual flow of the actuator.

For DFR1, there is no connection between port X and the reservoir.

For pressure controller functions, see DR control.

Static operating curve ($n_1=1500\text{rpm}$, $t_{oil}=50^\circ\text{C}$)

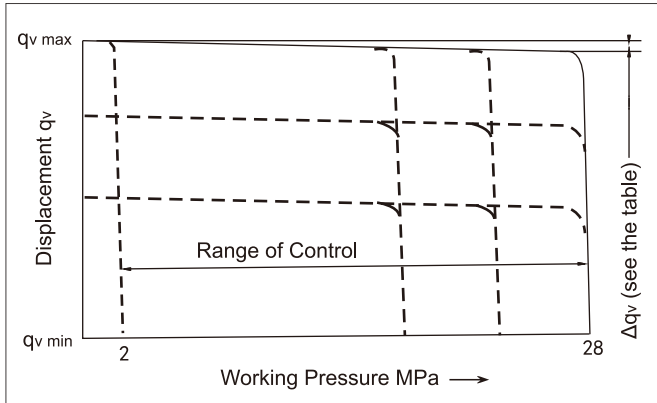

Operating curve at variable speed

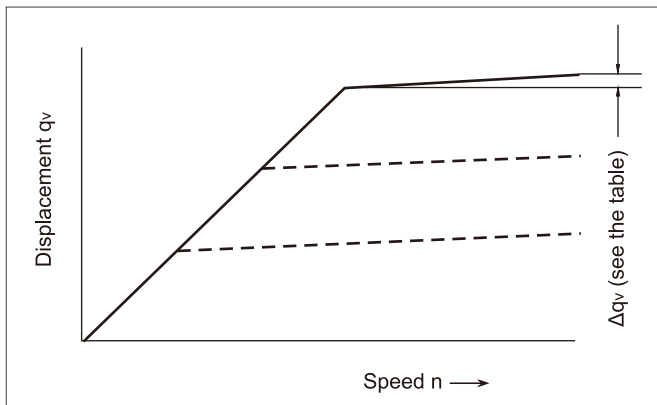

Dynamic flow operating curve

This curve indicates the average measurement in test conditions with the pump installed in the tank.

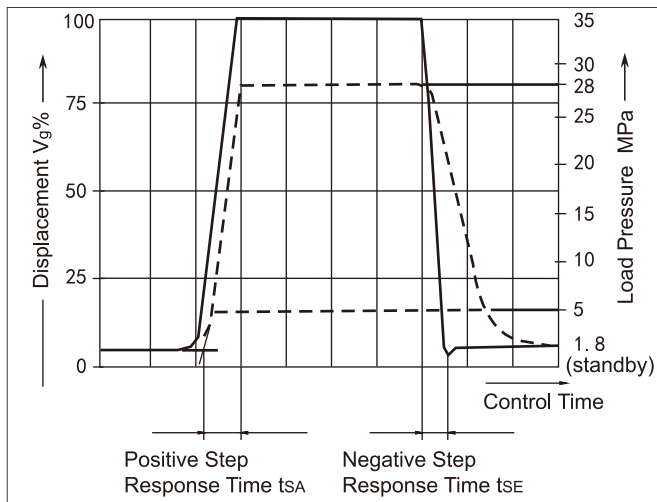

Controller time

Size	$t_{SA}(\text{ms})$ at 28MPa	$t_{SE}(\text{ms})$ at 28MPa	$t_{SE}(\text{ms})$ at 5MPa
18	40	15	40
28	40	20	40
45	50	25	50
71	60	30	60
100	120	60	120
110	120	60	120
140	130	60	130

Controller data

For controller data, see DR control.

Maximum flow deviation measured at drive speed $n=1500\text{rpm}$
(Hysteresis and increase)

Size	18	28	45	71	100	110	140
$\Delta q_{v\text{max}}$ L/min	0.5	1.0	1.8	2.8	4.0	4.0	6.0

DFR pilot fluid consumption _____ Max.3-4.5L/min

DFR1 pilot fluid consumption _____ Max.3L/min

Differential pressure Δp

Between 1 and 2 MPa (it may be set higher as required).

Standard setting: 1.4MPa. For different settings, please specify when ordering.

Relieving the load on port X to the reservoir results in a zero stroke pressure $P=1.8\pm 0.2\text{MPa}$ (standby) (dependent on Δp).

Circuit diagram

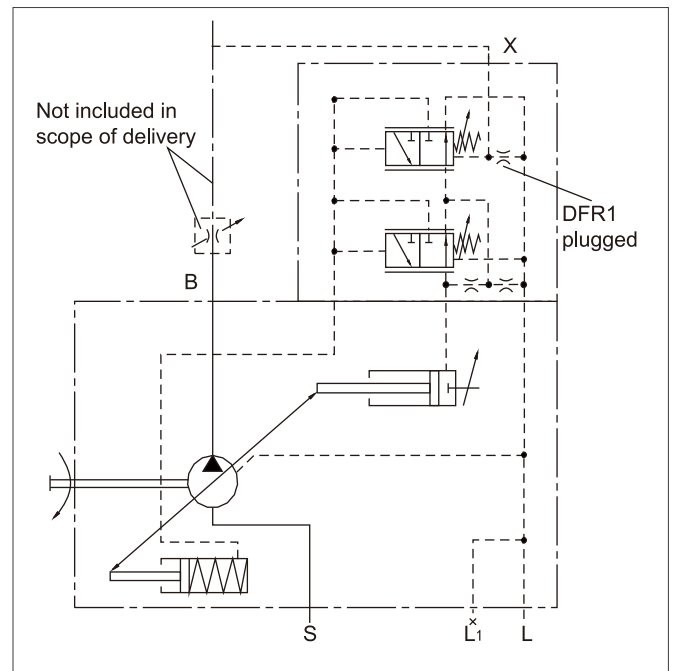

Ports

B _____ pressure port

S _____ inlet port

L/L1 _____ case drain port (L1 plugged)

X _____ pilot pressure port



➤ DFLR-Pressure/Flow/Constant Power Control

To obtain a constant drive torque with varying working pressures, the swivel angle and flow of the axial piston pump are varied so that the product of pressure and flow remains constant.

Flow control is possible below the constant power control curve.

Static operating curve

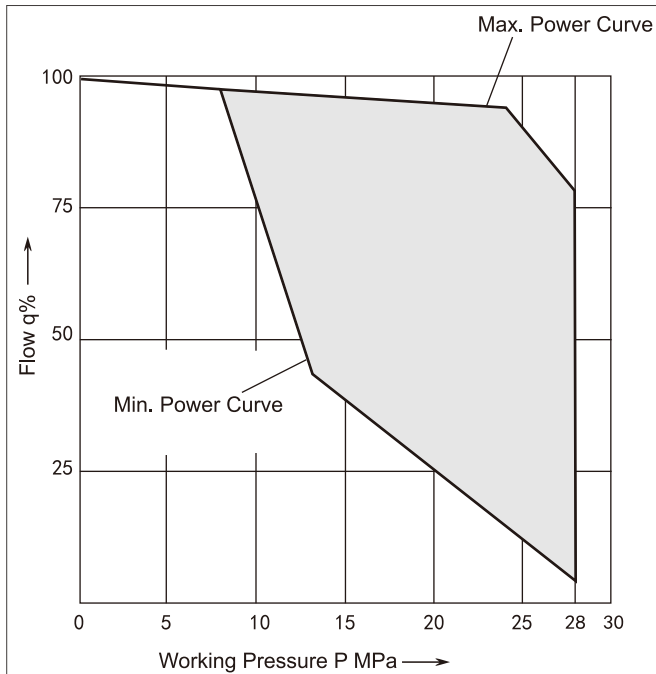

Power characteristic curves are factory set. Please describe in detail in plain text.

For example, 20 kW at 1500 min⁻¹.

Controller data

For technical data of pressure controller, see DR control.

For technical data of flow controller, see DFR/DFR1 control.

start of control _____ from 8MPa

Control fluid consumption _____ Max.5.5L/min

For flow loss at Q_{max}, see drive power and flow page.

Circuit diagram

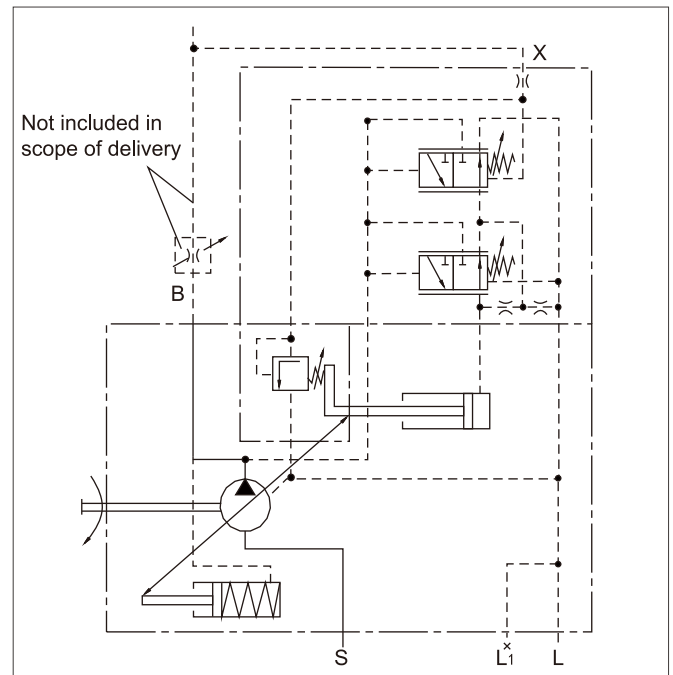

Ports

B _____ pressure port

S _____ inlet port

L/L1 _____ case drain port (L1 plugged)

X _____ pilot pressure port



► Installation Dimensions-DR Pressure Control

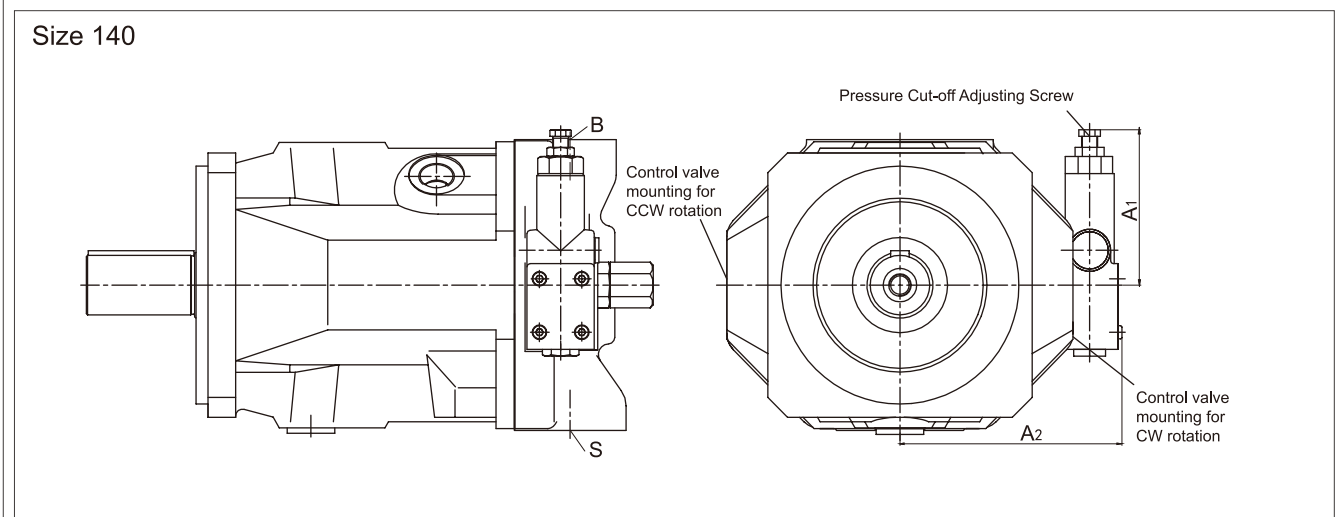
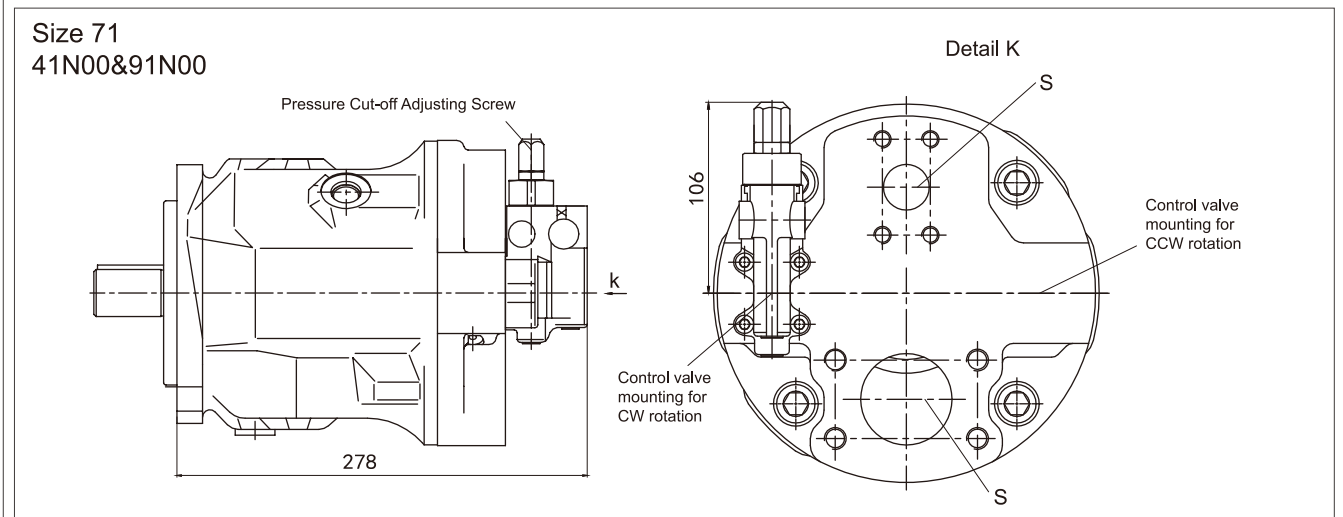
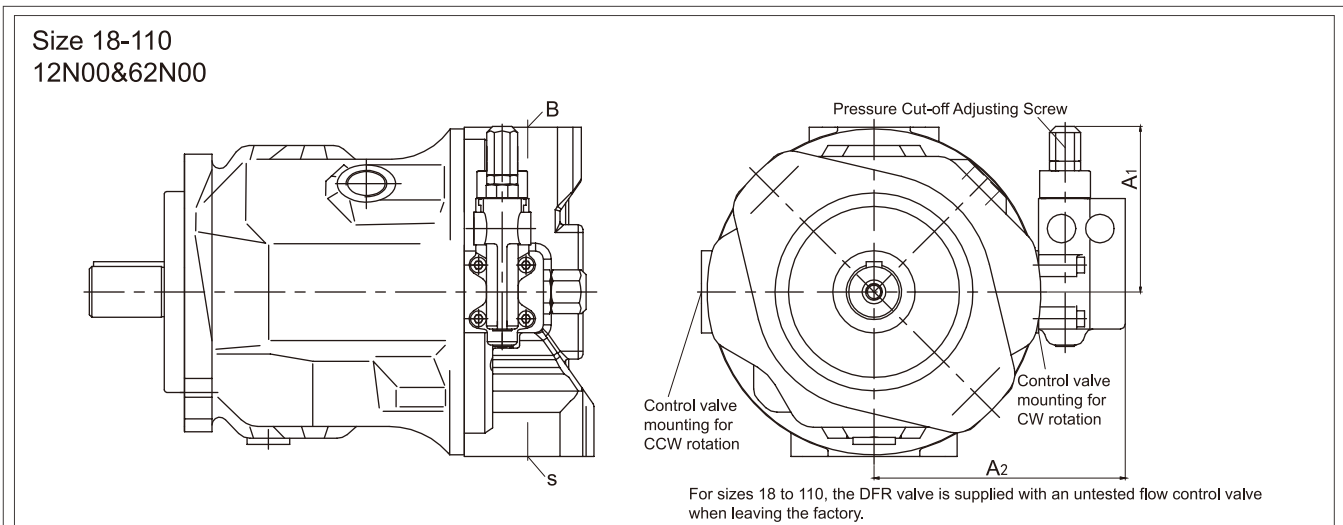

Size	A1	A2	Size	A1	A2
18	104.5	125.5	100	106	165
28	106	136	110	106	165
45	106	146	140	127	169
71	106	160			



► Installation Dimensions-DRG Pressure/Remotely Control

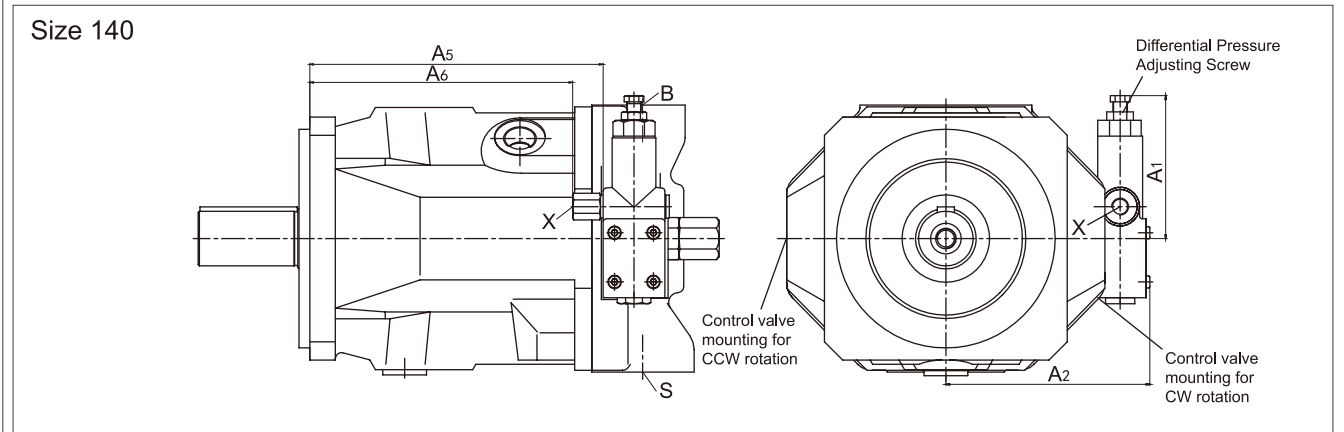
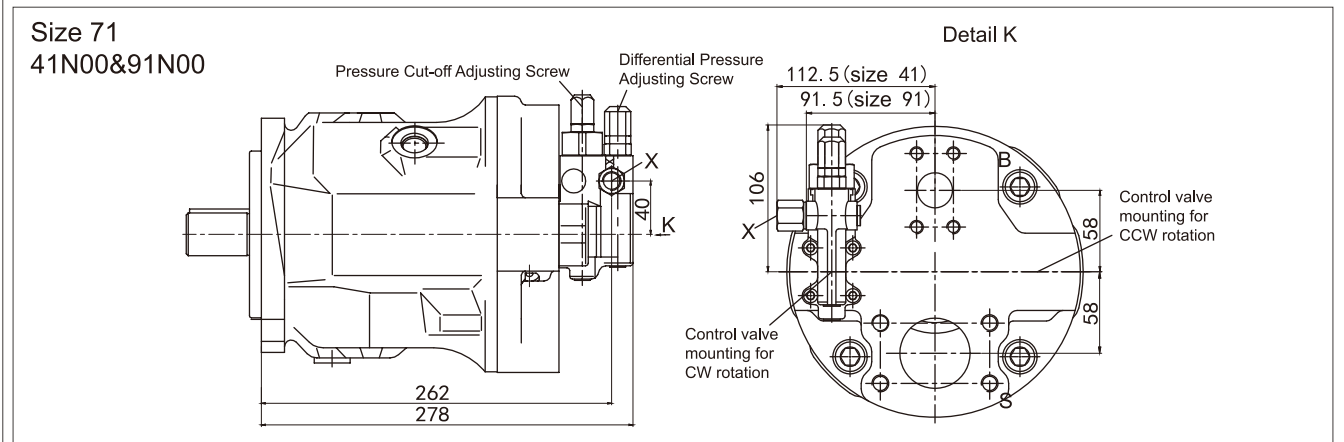
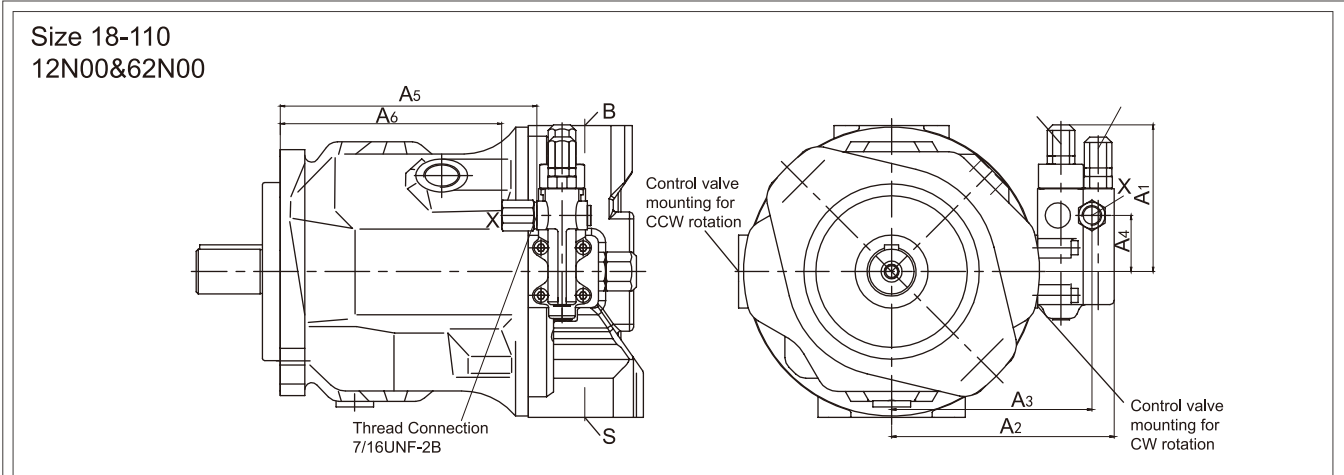

Size	A1	A2	A3	A4	A5	A6	Port X	
18ISO	104.5	125.5	109	40	-	109	M14×1.5, 12deep	With pipe joint
18SAE	104.5	125.5	109	40	130	-	7/16-20UNF-2B, 11.5deep	Without pipe joint
28ISO	106	136	119	40	-	119	M14×1.5, 12deep	With pipe joint
28SAE	106	136	119	40	138	-	7/16-20UNF-2B, 11.5deep	Without pipe joint
45ISO	106	146	129	40	-	134	M14×1.5, 12deep	With pipe joint
45SAE	106	146	129	40	153	-	7/16-20UNF-2B, 11.5deep	Without pipe joint
71ISO	106	160	143	40	-	162	M14×1.5, 12deep	With pipe joint
71SAE	106	160	143	40	181	-	7/16-20UNF-2B, 11.5deep	Without pipe joint
100/110ISO	106	165	148	40	-	229	M14×1.5, 12deep	With pipe joint
100/110SAE	106	165	148	40	248	-	7/16-20UNF-2B, 11.5deep	Without pipe joint
140ISO	127	169	143	27	244	-	M14×1.5, 12deep	Without pipe joint
140SAE	127	169	143	27	-	222	9/16-18UNF-2B, 13deep	With pipe joint



► Installation Dimensions-ED Electro proportional Remote Pressure Control

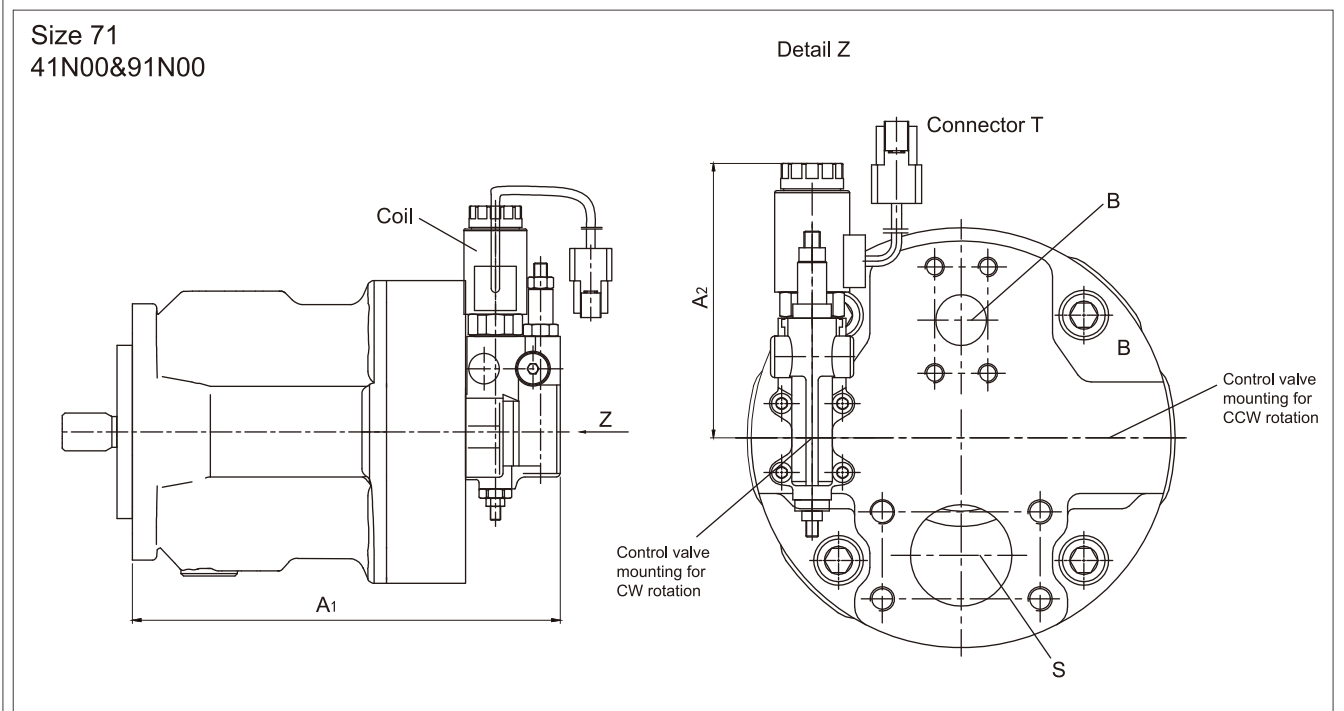
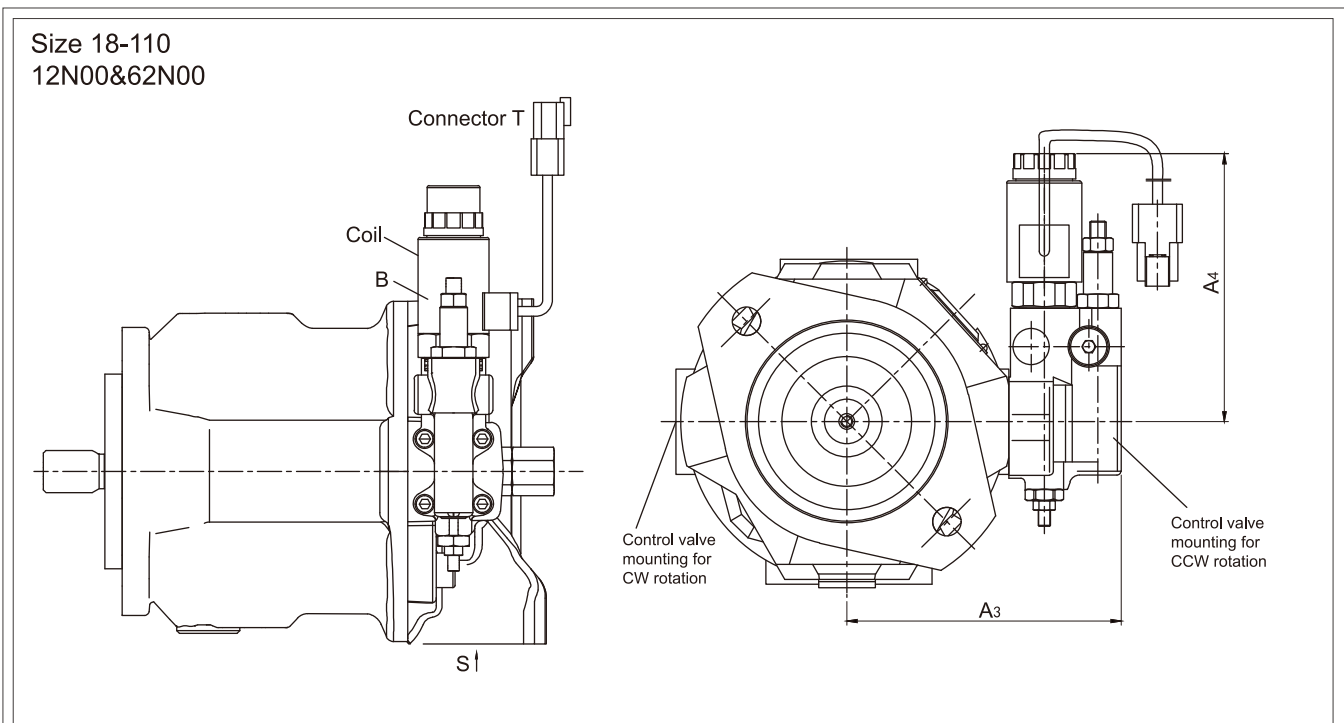

Size	A1	A2	A3	A4
18	-	-	126	140
28	-	-	136	140
45	-	-	146	140
71	278	140	160	140
100/110	-	-	165	140



► Installation Dimensions-DFR/DFR1 Pressure/Flow Control

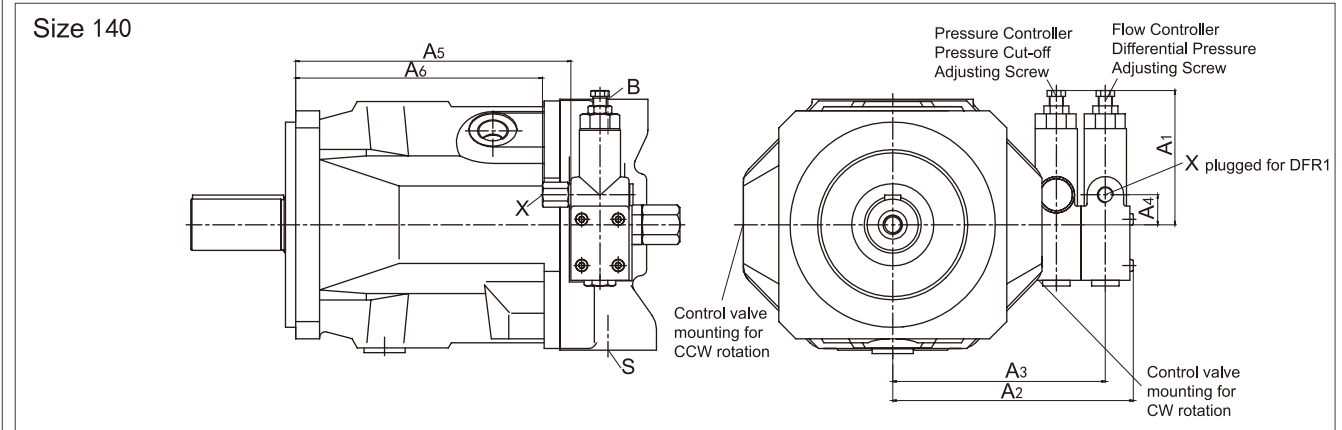
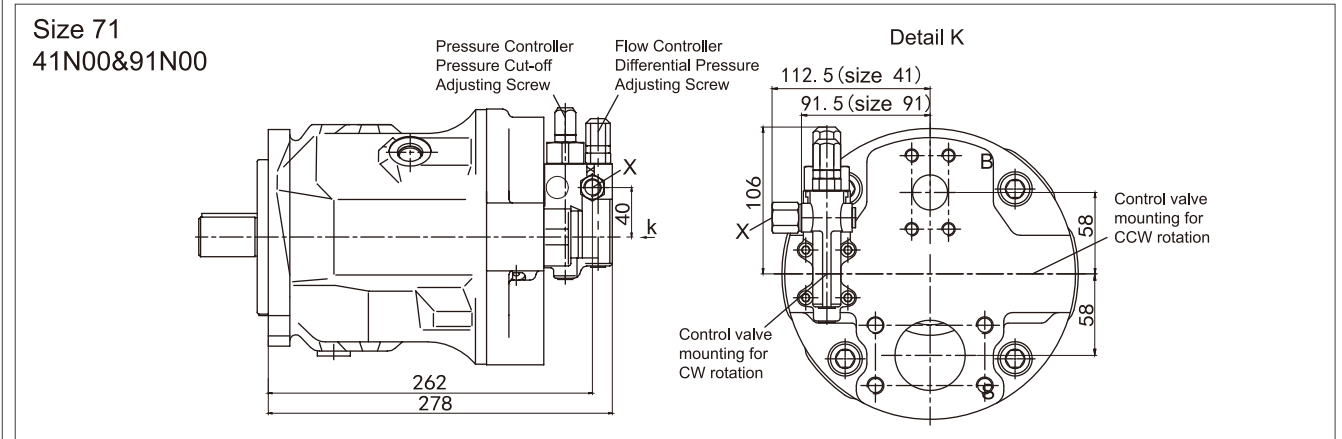
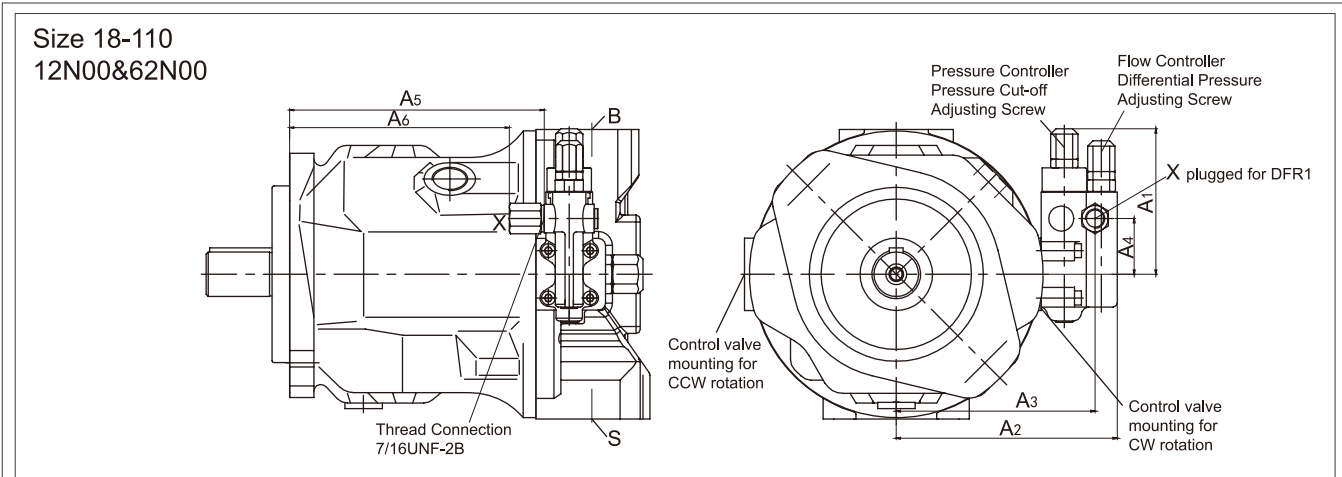

Size	A1	A2	A3	A4	A5	A6	Port X	
18ISO	104.5	125.5	109	40	-	109	M14×1.5, 12deep	With pipe joint
18SAE	104.5	125.5	109	40	130	-	7/16-20UNF-2B, 11.5deep	Without pipe joint
28ISO	106	136	119	40	-	119	M14×1.5, 12deep	With pipe joint
28SAE	106	136	119	40	138	-	7/16-20UNF-2B, 11.5deep	Without pipe joint
45ISO	106	146	129	40	-	134	M14×1.5, 12deep	With pipe joint
45SAE	106	146	129	40	153	-	7/16-20UNF-2B, 11.5deep	Without pipe joint
71ISO	106	160	143	40	-	162	M14×1.5, 12deep	With pipe joint
71SAE	106	160	143	40	181	-	7/16-20UNF-2B, 11.5deep	Without pipe joint
100/110ISO	106	165	148	40	-	229	M14×1.5, 12deep	With pipe joint
100/110SAE	106	165	148	40	248	-	7/16-20UNF-2B, 11.5deep	Without pipe joint
140ISO	127	209	183	27	244	-	M14×1.5, 12deep	With pipe joint
140SAE	127	209	183	27	-	222	9/16-18UNF-2B, 13deep	With pipe joint



► Installation Dimensions-DFLR Pressure/Flow/Constant Power Control

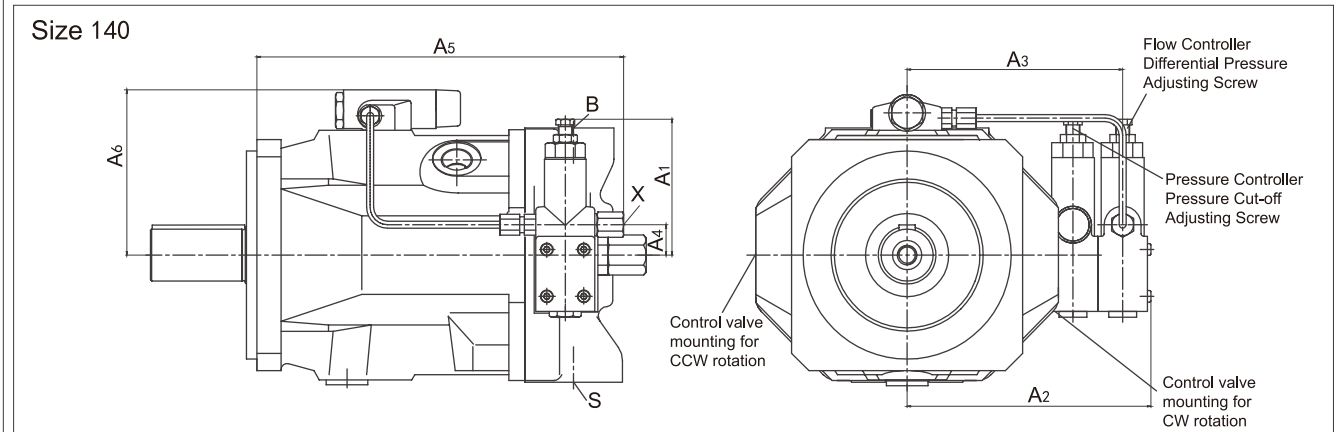
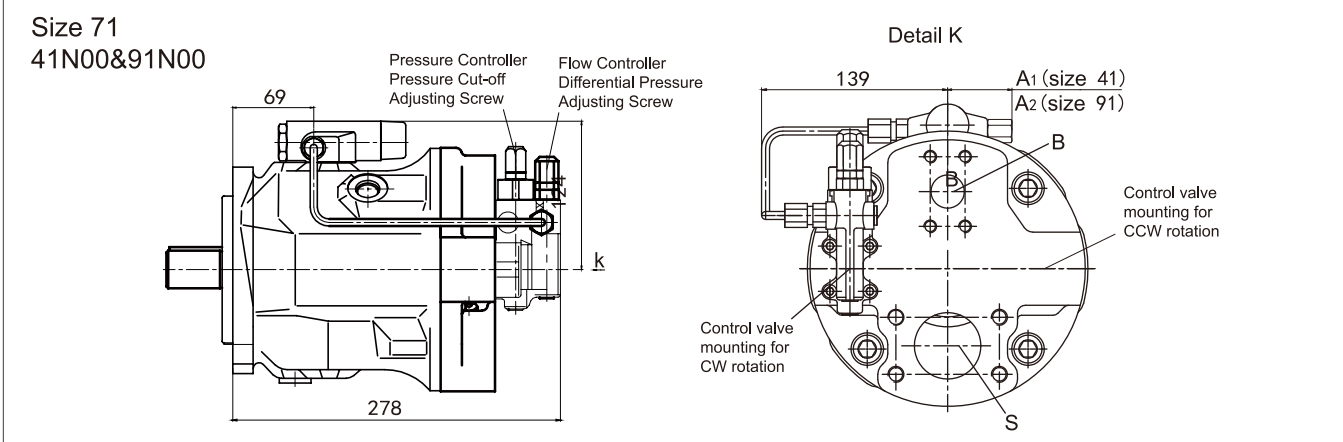
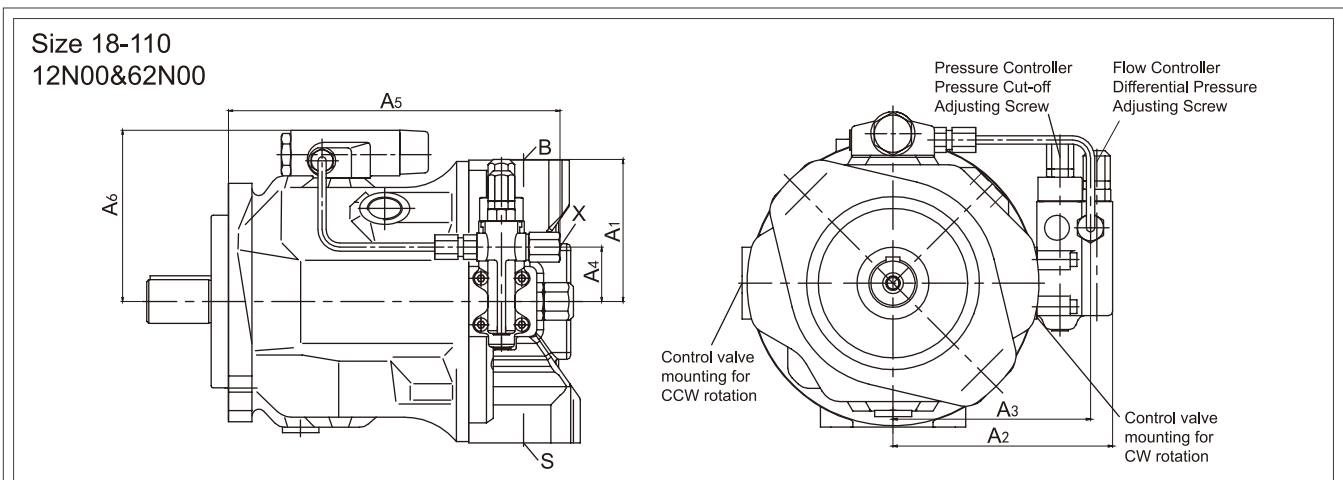

Size	A1	A2	A3	A4	A5	A6	Port X
28ISO	106	136	119	40	197	107	M14×1.5, 12deep
28SAE	106	136	119	40	194	107	7/16-20UNF-2B, 11.5deep
45ISO	106	146	129	40	212	112	M14×1.5, 12deep
45SAE	106	146	129	40	209	112	7/16-20UNF-2B, 11.5deep
71ISO	106	51	143	40	240	124	M14×1.5, 12deep
71SAE	48	160	143	40	237	124	7/16-20UNF-2B, 11.5deep
100/110ISO	106	165	148	40	307	129	M14×1.5, 12deep
100/110SAE	106	165	148	40	304	129	7/16-20UNF-2B, 11.5deep
140ISO	127	209	183	26	314	140	M14×1.5, 12deep
140SAE	127	209	183	26	314	140	9/16-18UNF-2B, 13deep



> Through Drive

HA10VSO pumps are supplied with through drives based on the model code on the through drive classification code page. The type of through drive is indicated with a code (KB2-K21). A single code is enough if the manufacturer provides no additional pump. Shipping package includes: Shaft hub, fastening screws, seals and if necessary, connecting flange.

> Combined pump

The combination of several pumps may form independent circuits: When ordering combination pumps that include HA10VSO and require delivery in assembled state, the two item codes must be joined by a “+”.

Order example:
HA10VSO 71 DR/31 L-PPA12KB3 + HA10VSO 28 DR/31 L-PSA12NOO

> Max. Permissible Input and Through Drive Torques

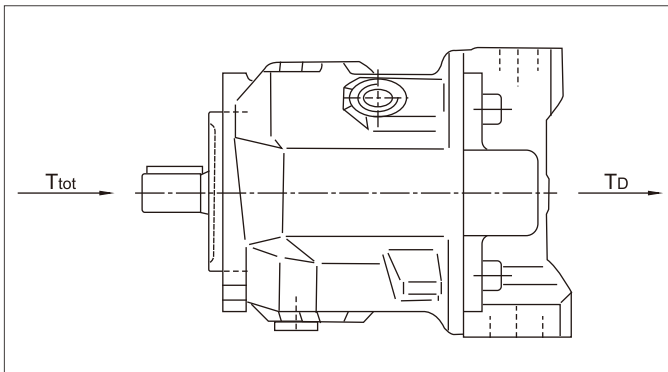

Torque distribution between pumps 1 and 2 is optional. The maximum permissible input torque T_{tot} and the maximum permissible through drive torque T_D shall not exceed the specified values.

> Permissible Moment of Inertia

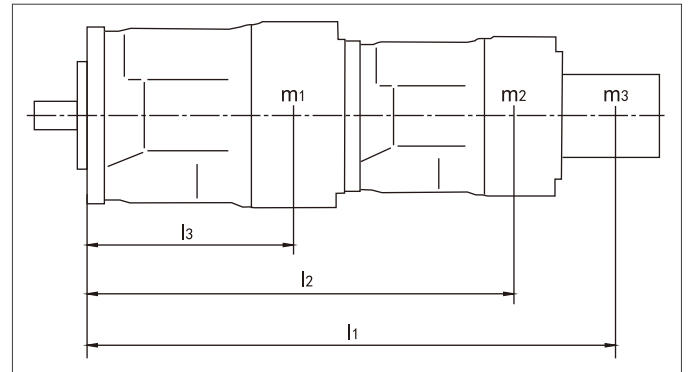

Size	18	28	45	71	100	110	140	
Permissible bending moment								
T_m	Nm	580	880	1370	2160	3000	3000	4500
Permissible moment of inertia at $10g \Delta 98.1m/s^2$								
T_m	Nm	50	88	137	216	300	300	450
mass								
m_1	kg	12	16	21	33	45	45	60
Distance to center of gravity								
l_1	mm	90	110	130	150	160	160	160

Size	28	45	71	100	110	140
Max. permissible input torque on shaft P of pump 1						
T_{tot}	Nm	137	200	439	857	1206
Max. permissible through drive torque						
T_D	Nm	137	200	439	778	1206
T_{Dkeyed}	Nm	112	179	283	398	557

Size	18	28	45	71	100	110	140
Max. permissible input torque on shaft S of pump 1							
T_{tot}	Nm	80	137	319	626	1104	1620
Max. permissible through drive torque							
T_D	Nm	80	160	319	492	778	1206
T_{Dkeyed}	Nm	80	112	179	283	398	557

Size	28	45	71	100	110	140	
Max. permissible input torque on shaft R of pump 1							
T_{tot}	Nm	225	400	644	-	-	-
Max. permissible through drive torque							
T_D	Nm	176	365	548	-	-	-
T_{Dkeyed}	Nm	112	179	283	-	-	-

T_{tot} =max. permissible input torque of pump 1
 T_D =max. permissible through-drive torque on through drive and splined shaft
 T_{Dkeyed} =max. permissible through-drive torque on through drive and keyed shaft



➤ Installation Dimensions-Combination Pumps

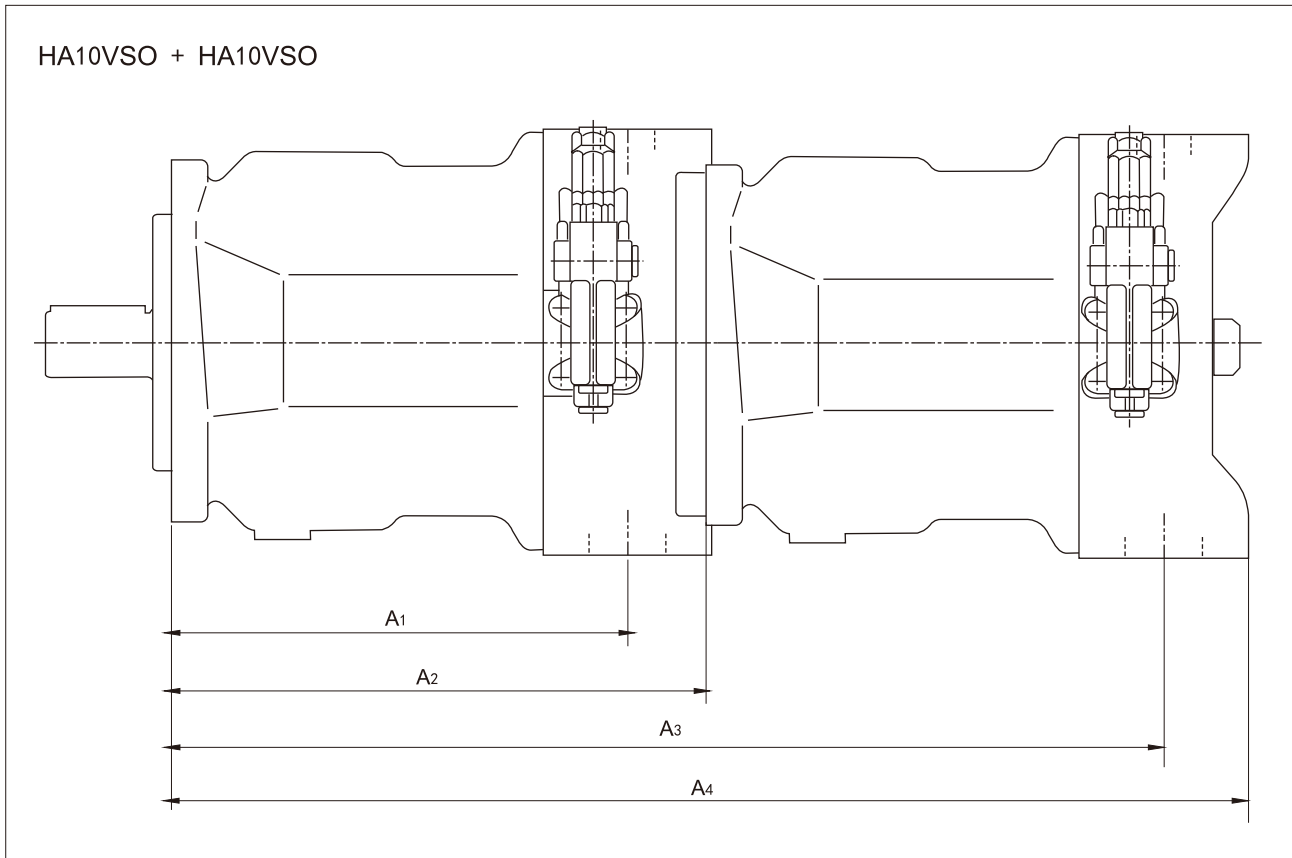

main pump auxiliary pump	HA10VSO18				HA10VSO28				HA10VSO45				HA10VSO71				HA10VSO100/110				HA10VSO140			
	A1	A2	A3	A4	A1	A2	A3	A4	A1	A2	A3	A4	A1	A2	A3	A4	A1	A2	A3	A4	A1	A2	A3	A4
HA10VSO18	164	204	349	399	164	204	349	399	184	229	374	424	217	267	412	462	275	338	483	533	275	350	495	545
HA10VSO28	-	-	-	-	164	204	368.5	410	184	229	374	435	217	267	431.5	431.5	275	338	502.5	544	275	350	514	556
HA10VSO45	-	-	-	-	-	-	-	-	184	229	393.5	453	217	267	491	491	275	338	522	562	275	350	534	574
HA10VSO71	-	-	-	-	-	-	-	-	-	-	-	-	217	267	524	524	275	338	555	595	275	350	567	609
HA10VSO100	-	-	-	-	-	-	-	-	-	-	-	-	-	-	-	-	275	338	613	664	275	350	625	679
HA10VSO110	-	-	-	-	-	-	-	-	-	-	-	-	-	-	-	-	-	-	-	-	275	350	625	679
HA10VSO140	-	-	-	-	-	-	-	-	-	-	-	-	-	-	-	-	-	-	-	-	275	350	625	688



➤ Installation Dimensions-Through Drive

Flange ISO 80, 2-hole, for connection of another HA10VSO18 pump (splined shaft S or R)
Ordering model KB2

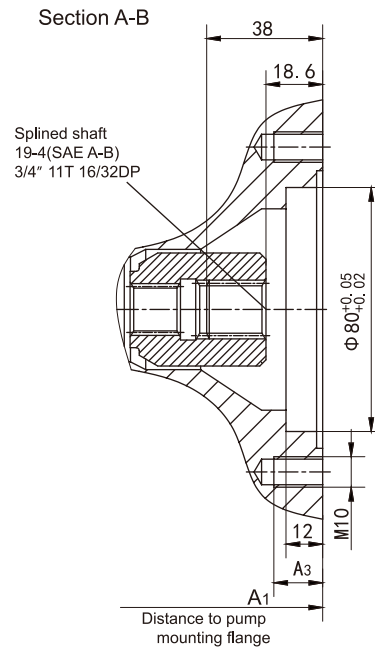
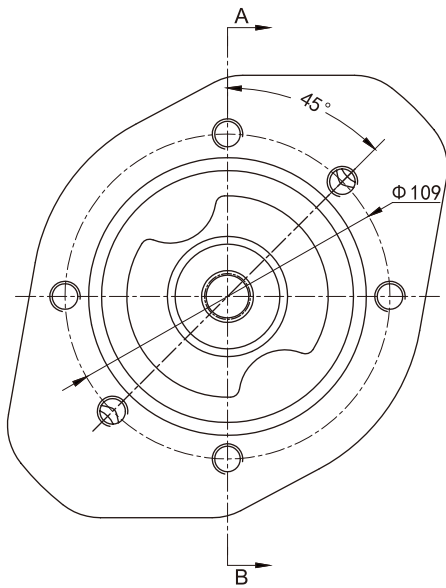

Main Pump Size	A ₁	A ₃	A ₄
28	204	16	41.6
45	229	16	46.1
71	267	20	52.1

Flange ISO 80, 2-hole, for connection of another HA10VSO18 pump (keyed shaft P)
Ordering model K51

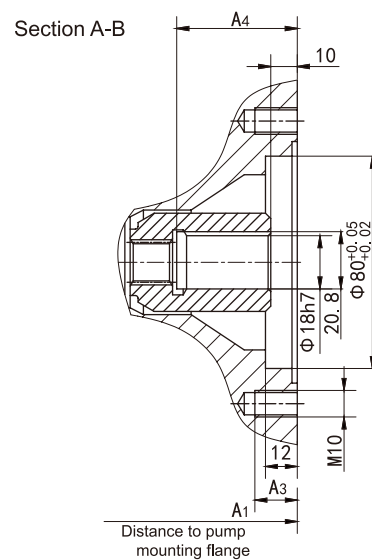
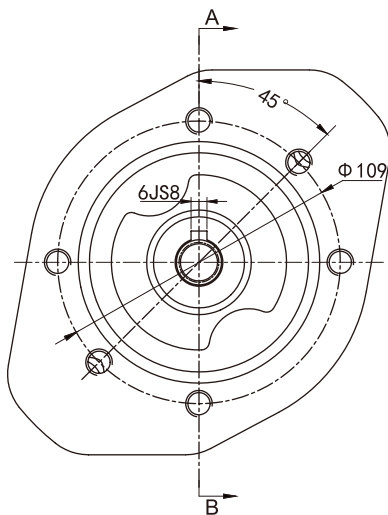

Main Pump Size	A ₁	A ₃	A ₄
28	204	16	37
45	229	16	43
71	267	20	51
100	338	20	55
110	338	20	55
140	350	20	67



► Installation Dimensions-Through Drive

Flange ISO 100, 2-hole, for connection of another HA10VSO28 pump (splined shaft S or R)
 Ordering model KB3

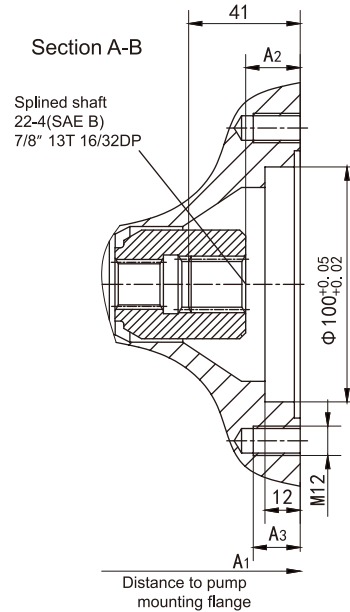
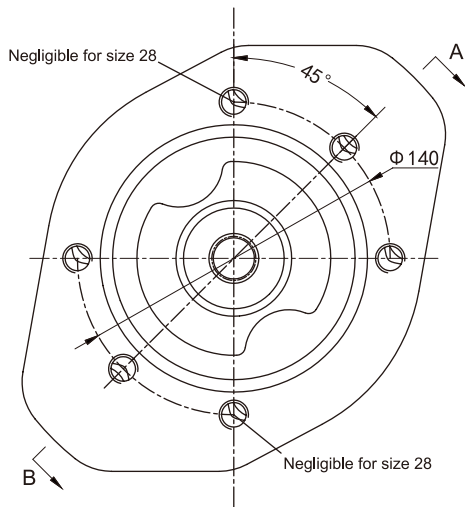

Main Pump Size	A1	A2	A3
28	204	19.2	14
45	229	16.5	15
71	267	16.5	18
100	338	17.6	18
110	338	17.6	18
140	350	18.2	24

Flange ISO 100, 2-hole, for connection of another HA10VSO28 pump (keyed shaft P)
 Ordering model K25

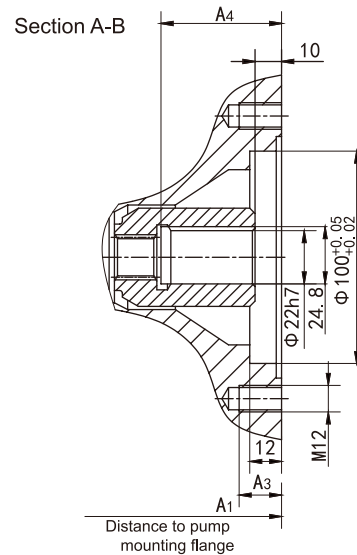
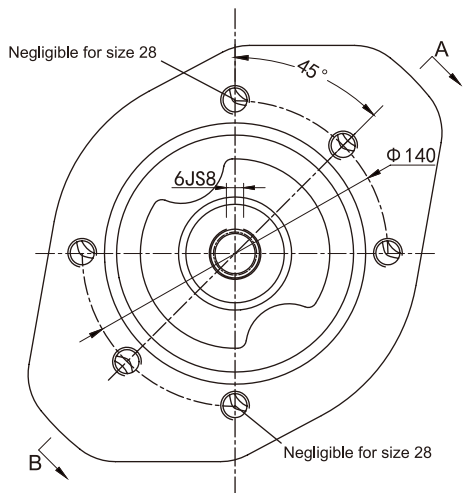

Main Pump Size	A1	A3	A4
28	204	14	37
45	229	14	43
71	267	23	51
100	338	20	55
110	338	20	55
140	350	24	62



➤ Installation Dimensions-Through Drive

Flange ISO 100, 2-hole, for connection of another HA10VSO45 pump (splined shaft S or R)
 Ordering model KB4

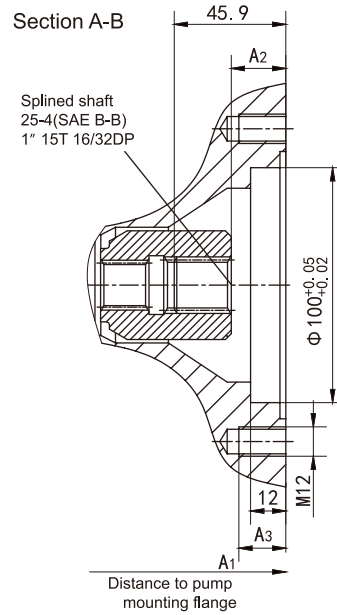
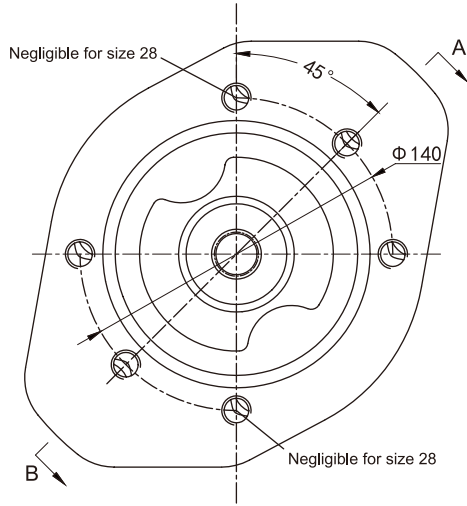

Main Pump Size	A ₁	A ₂	A ₃
45	229	17.2	14
71	267	17.2	18
100	338	18.2	20
110	338	18.2	20
140	350	18.2	24

Flange ISO 100, 2-hole, for connection of another HA10VSO45 pump (keyed shaft P)
 Ordering model K26

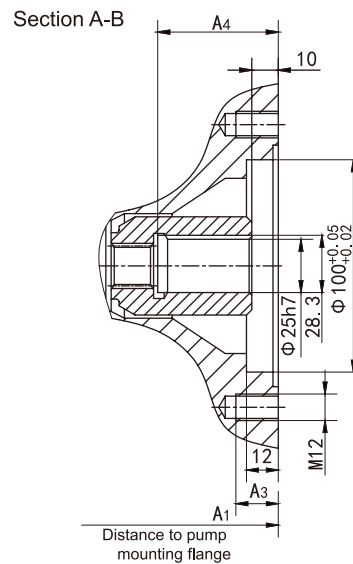
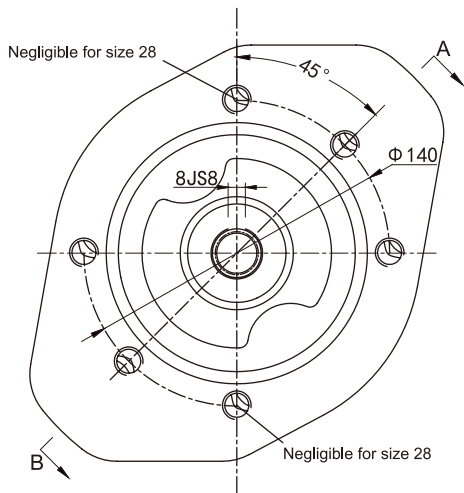

Main Pump Size	A ₁	A ₃	A ₄
45	229	14	43
71	267	23	51
100	338	20	56
110	338	20	56
140	350	24	67



► Installation Dimensions-Through Drive

Flange ISO 125, 2-hole, for connection of another HA10VSO71 pump (splined shaft S or R)
 Ordering model KB5

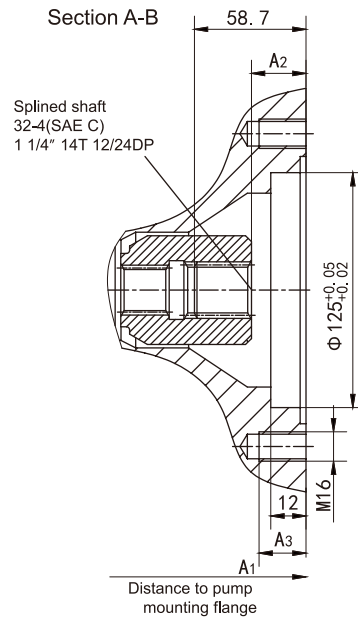
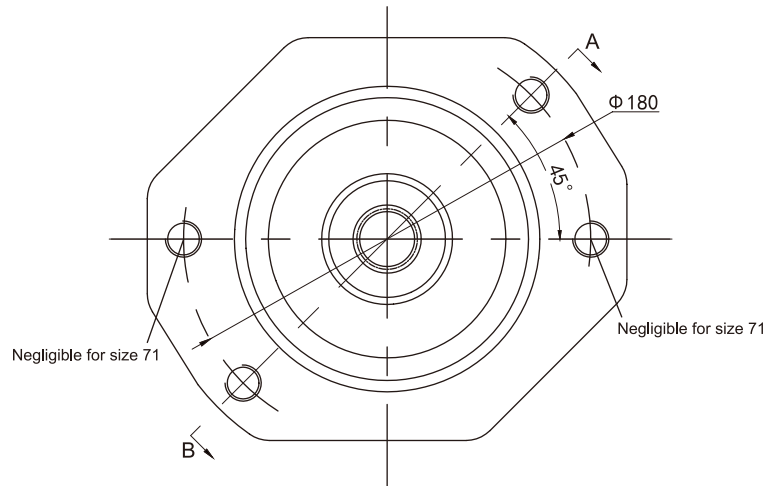

Main Pump Size	A1	A2	A3
71	267	20	18.5
100	338	20	25
110	338	20	25
140	350	21	32

Flange ISO 125, 2-hole, for connection of another HA10VSO71 pump (keyed shaft P)
 Ordering model K27

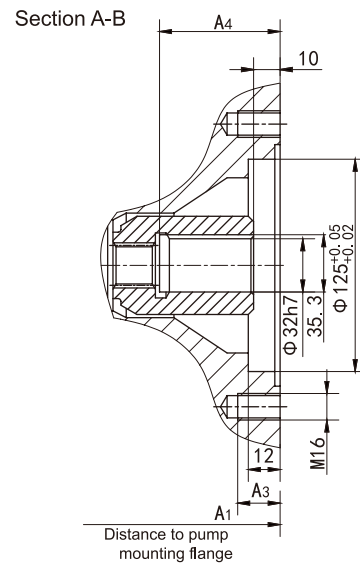
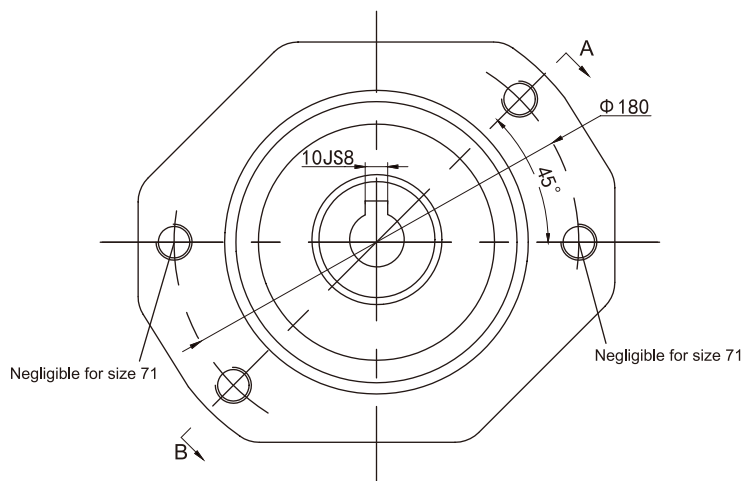

Main Pump Size	A1	A3	A4
71	267	18	51
100	338	20	54
110	338	20	54
140	350	24	63



► Installation Dimensions-Through Drive

Flange ISO 125, 2-hole, for connection of another HA10VSO100 pump (splined shaft S)
 Ordering model KB6

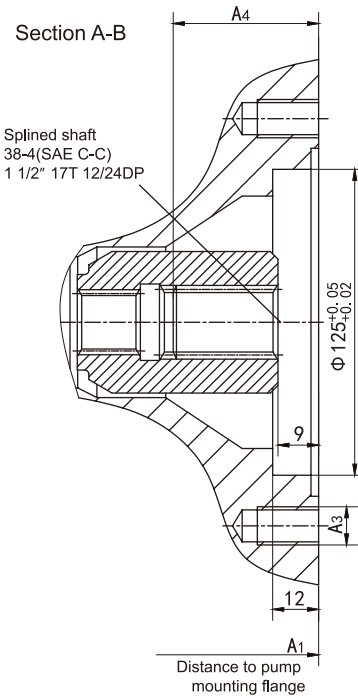
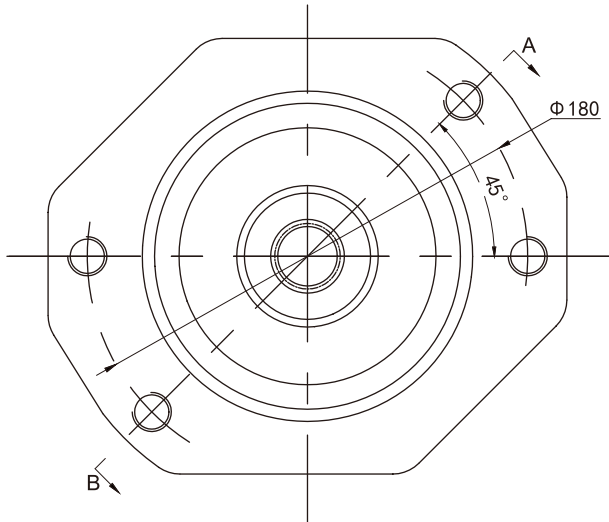

Main Pump Size	A ₁	A ₃	A ₄
100	338	M16, 25deep	65
110	338	M16, 25deep	65
140	350	M16, 32deep	77.3

Flange ISO 180, 4-hole, for connection of another HA10VSO140 pump (splined shaft S)
 Ordering model KB7

Main Pump Size HA10VSO140

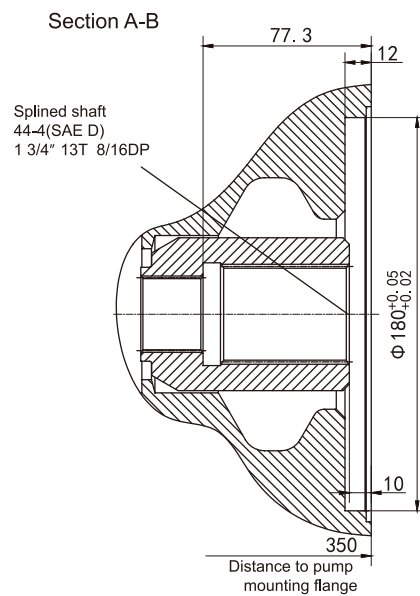
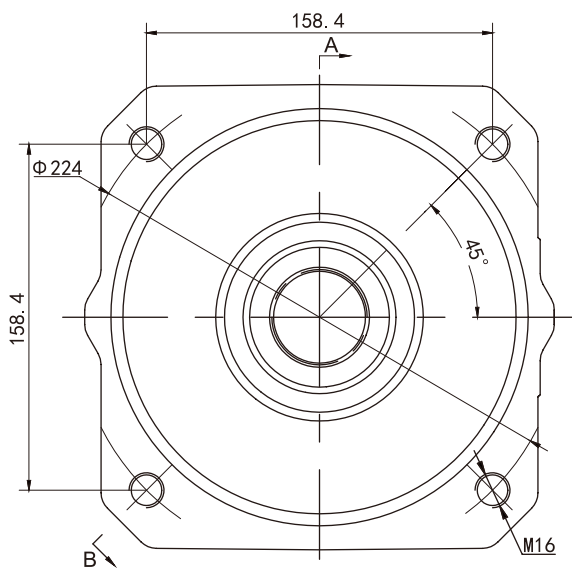



► Installation Dimensions-Through Drive

Flange SAE 82-2(SAE A, 2-hole)

Ordering model K01

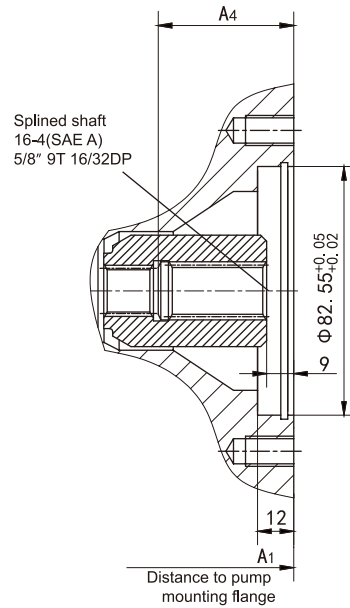
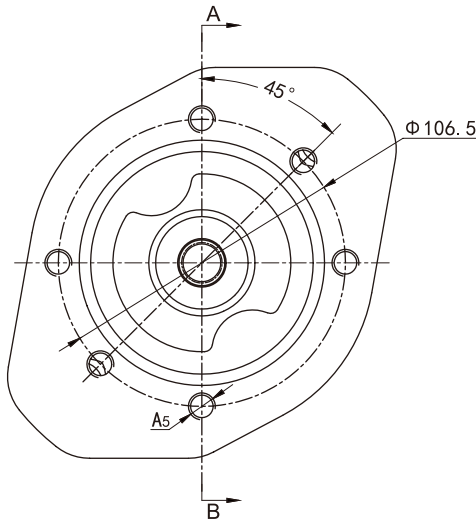

Main Pump Size	A ₁	A ₄	A ₅
28	204	47	M10, 16deep
45	229	53	M10, 16deep
71	267	61	M10, 20deep
100	338	65	M10, 20deep
110	338	65	M10, 20deep
140	350	77	M10, 20deep

Flange SAE 82-2(SAE A, 2-hole)

Ordering model K01M

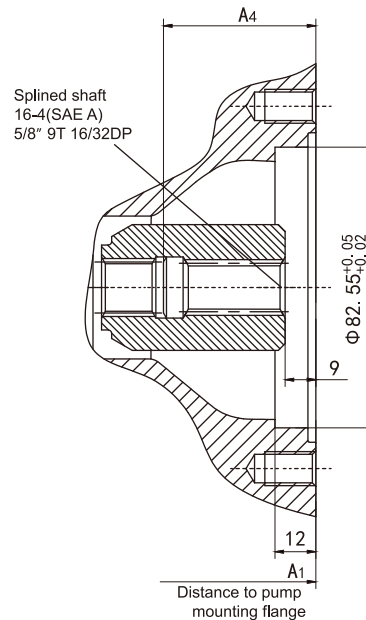
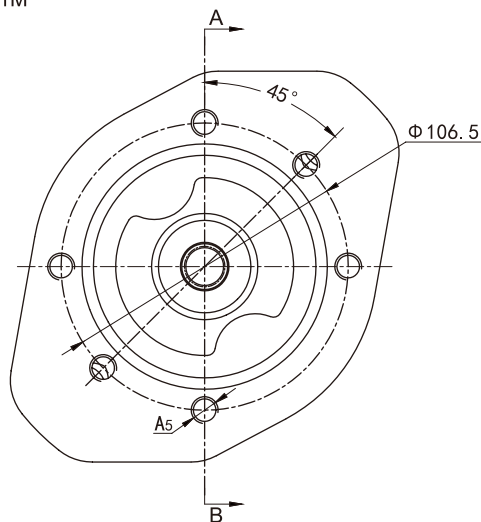

Main Pump Size	A ₁	A ₄	A ₅
28	204	47	M10, 16deep
45	229	53	M10, 16deep
71	267	61	M10, 20deep
100	338	65	M10, 20deep
110	338	65	M10, 20deep
140	350	77	M10, 20deep



➤ Installation Dimensions-Through Drive

Flange SAE 82-2(SAE A, 2-hole), for connection of another HA10VSO18 pump (splined shaft S)
 Ordering model K52

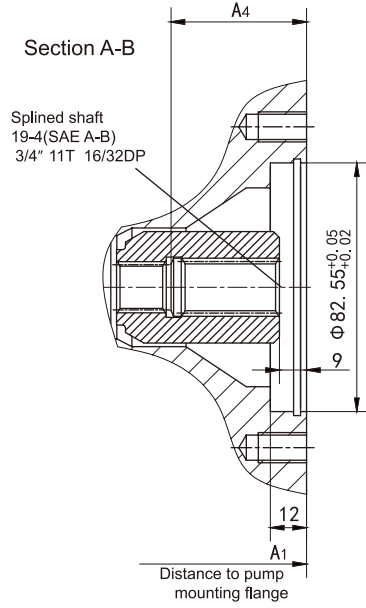
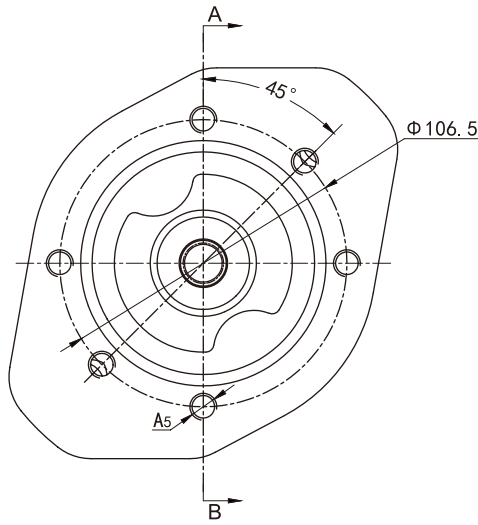

Main Pump Size	A ₁	A ₄	A ₅
28	204	47	M10, 16deep
45	229	53	M10, 16deep
71	267	61	M10, 20deep
100	338	65	M10, 20deep
110	338	65	M10, 20deep
140	350	77	M10, 20deep



► Installation Dimensions-Through Drive

Flange SAE 101-2(SAE B, 2-hole), for connection of another HA10VSO28 pump (splined shaft S)
 Ordering model K02

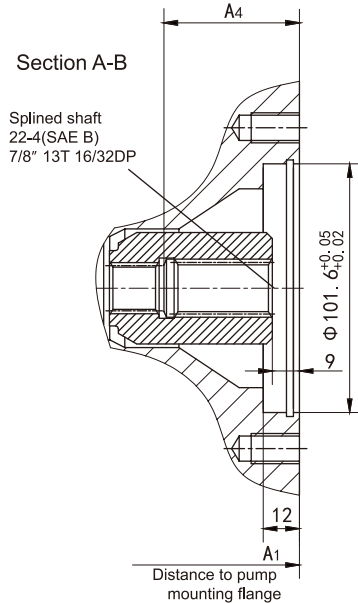
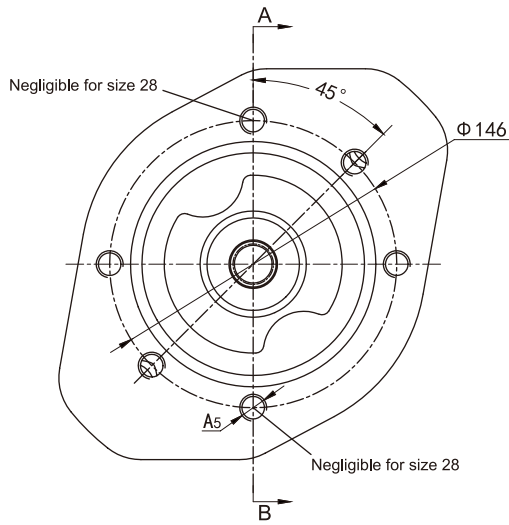

Main Pump Size	A ₁	A ₄	A ₅
28	204	47	M12, 15deep
45	229	53	M12, 18deep
71	267	61	M12, 20deep
100	338	65	M12, 20deep
110	338	65	M12, 20deep
140	350	77	M12, 20deep

Flange SAE 101-2(SAE B, 2-hole), for connection of another HA10VSO28 pump (splined shaft S)
 Ordering model K68

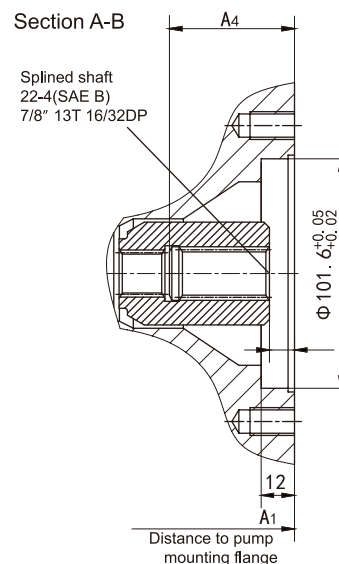
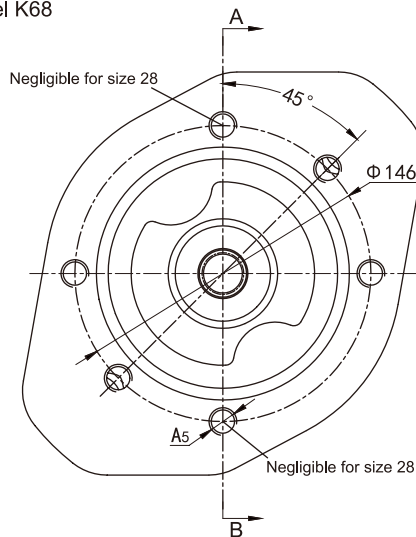

Main Pump Size	A ₁	A ₄	A ₅
28	204	47	M12, 15deep
45	229	53	M12, 18deep
71	267	61	M12, 20deep
100	338	65	M12, 20deep
110	338	65	M12, 20deep
140	350	77	M12, 20deep



➤ Installation Dimensions-Through Drive

Flange SAE 101-2(SAE B, 2-hole), for connection of another HA10VSO45 pump (splined shaft S)

Ordering model K04

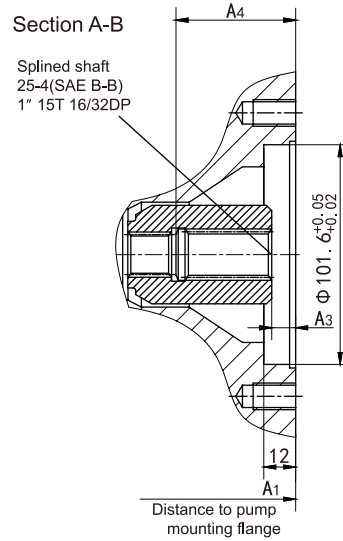
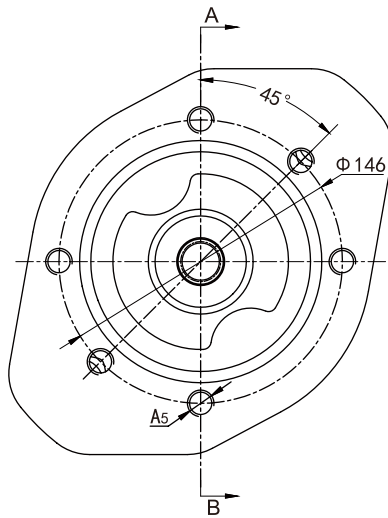

Main Pump Size	A ₁	A ₃	A ₄	A ₅
28	204	9	47	M12, 15deep
45	229	9	53.4	M12, 18deep
71	267	9	61.3	M12, 20deep
100	338	10	65	M12, 20deep
110	338	10	65	M12, 20deep
140	350	8	77.3	M12, 20deep

Flange SAE 127-2(SAE C, 2-hole), for connection of another HA10VSO71 pump (splined shaft S)

Ordering model K07

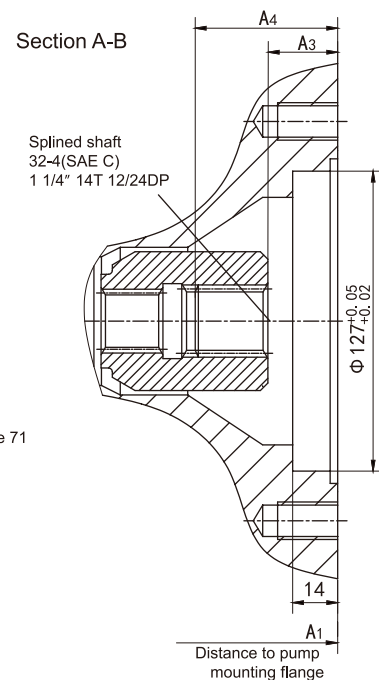
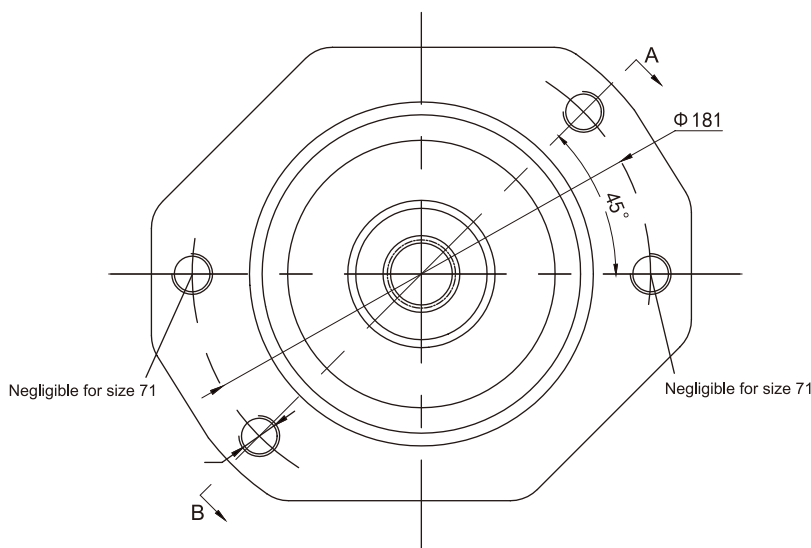

Main Pump Size	A ₁	A ₃	A ₄	A ₅
71	267	10	61.3	M16, 18deep
100	338	9	65	M16, 20deep
110	338	9	65	M16, 20deep



► Installation Dimensions-Through Drive

Flange SAE 127-2(SAE C, 2-hole), for connection of another HA10VSO100 pump (splined shaft S)
 Ordering model K24

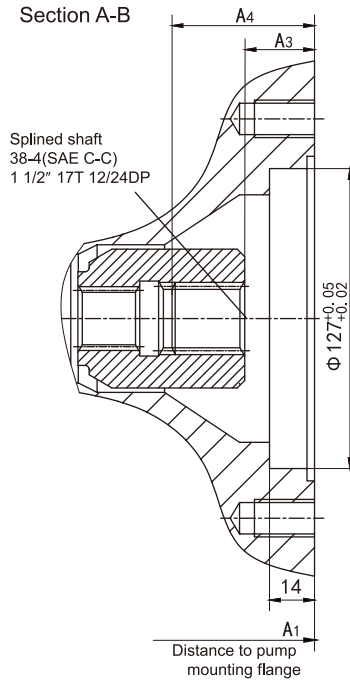
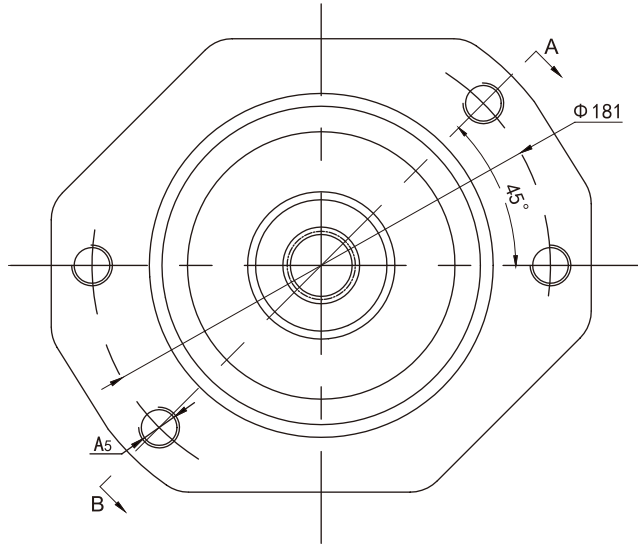

Main Pump Size	A1	A3	A4	A5
100	338	8	65	M16, 20deep
110	338	8	65	M16, 20deep
140	350	9	77.3	M16, 32deep

Flange SAE 152-4(SAE D, 4-hole), for connection of another HA10VSO140 pump (splined shaft S)
 Ordering model K17
 Main Pump Size HA10VSO140

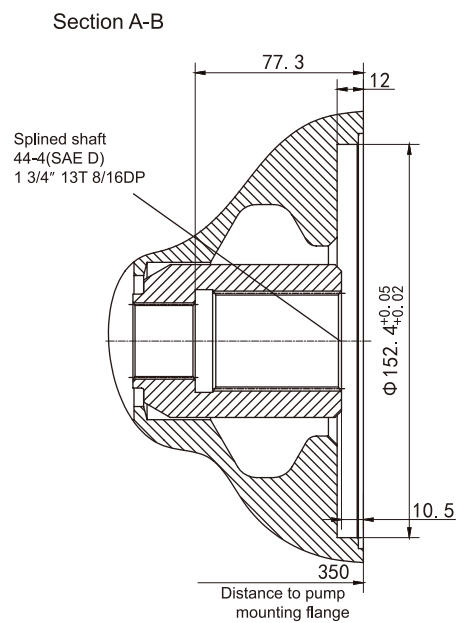
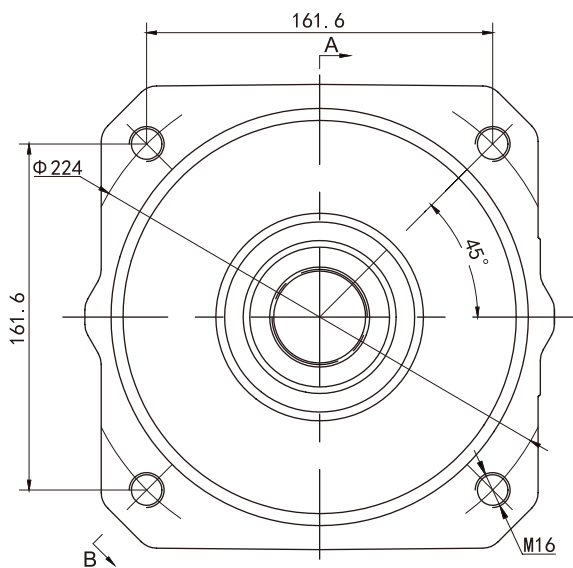



Installation Instructions

Any position you prefer.

The pump must be filled with hydraulic fluid during commissioning and operation.

To reduce noise, all connecting lines (inlet line, pressure line and case drain line) must be isolated from the reservoir with flexible components. Do not install any check valve in the case drain line.

You must consult us before implementation in special cases.

Vertical Installation (drive shaft upwards)

The installation below is for your reference:

a. Inside-reservoir installation

Fill the pump and lay it horizontal before installation.

a) If the minimum fluid level of the reservoir is equal to or higher than the mounting flange surface of the pump, plug port L, and open ports L1 and S; connect pipes to ports L1 and S as shown in FIG. 1.

b) If the minimum fluid level of the reservoir is below the mounting flange surface of the pump, connect pipes to ports L1 and S as shown in FIG. 2.

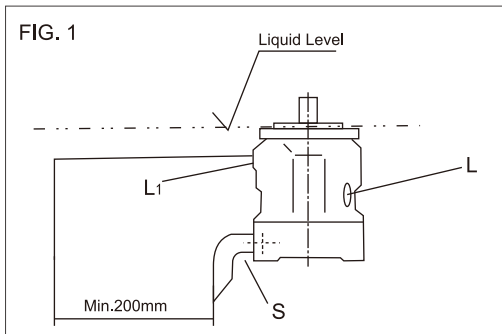

b. Outside-reservoir installation

Fill the pump and lay it horizontal before installation. See FIG. 2 for above-reservoir installation.

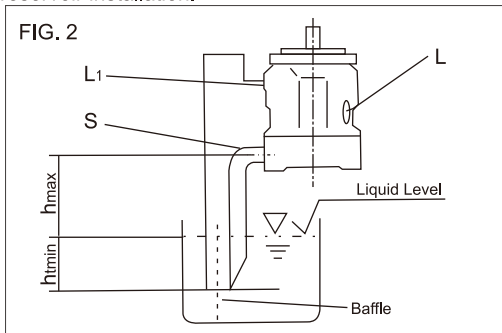

Restriction: Minimum inlet pressure under static and dynamic conditions

$$P_{absmin} = 0.8 \text{ bar}$$

Note: Do not install the pump above the reservoir as far as possible to reduce noise.

The permissible suction height h results from the total pressure loss, but it should not exceed $h_{max} = 800 \text{ mm}$ (pipe immersion depth $h_{min} = 200 \text{ mm}$).

Total pressure loss

$$\Delta p_{tot} = \Delta p_1 + \Delta p_2 + \Delta p_3 \leq (1 - P_{absmin}) = 0.2 \text{ bar}$$

Δp_1 : pipe pressure loss from fluid column acceleration

$$\Delta p_1 = \frac{\rho \cdot l \cdot dv}{dt} \cdot 10^{-6} \text{ (MPa)}$$

Δp_2 : pressure loss from hydrostatic head

$$\Delta p_2 = h \cdot \rho \cdot g \cdot 10^{-6} \text{ (MPa)}$$

Δp_3 : pipe loss (elbow, etc.)

ρ = viscosity (kg/m²)

dv/dt = rate of change in fluid velocity (m/s²)

g = acceleration of gravity = 9.81 m/s²

l = pipe length (m)

h = height (m)

Horizontal Installation

For horizontal installation, set port L or L1 on the top.

The installation below is for your reference:

a. Inside-reservoir installation

a) If the minimum fluid level of the reservoir is above the top of the pump, plug port L1; you may open ports L and S, and connect pipes to the two ports (as shown in FIG. 3).

b) If the minimum fluid level of the reservoir is below the top of the pump, plug port L1; see FIG. 4 for pipe connection of port L and possibly port S.

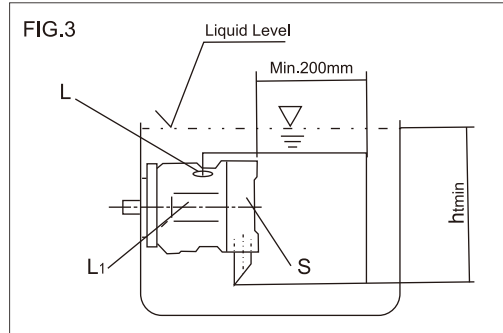

b. Outside-reservoir installation

Fill the pump before commissioning.

Connect pipes to port S and the top port L or L1.

a) See FIG. 4 for above-reservoir installation.

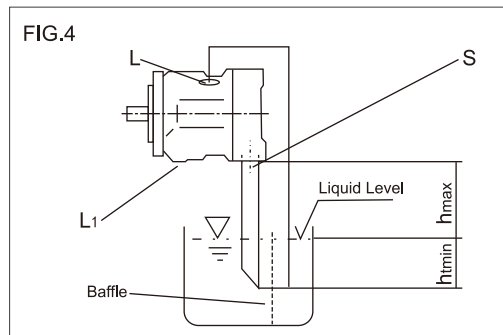

b) Below-reservoir installation

See FIG. 5 for pipe connection of ports L1 and S. Port L is plugged.

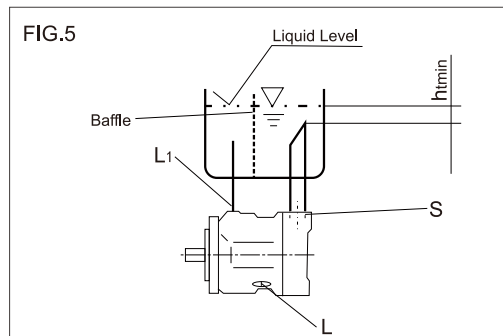









Since 2002

Over twenty years of deep cultivation in the field of hydraulic Solutions

HYTEK is a high technology enterprise integrating R&D, production, sales and service of hydraulic power products. Provides professional hydraulic transmission control products and solutions for construction machinery, road machinery, material handling machinery, agricultural and forestry machinery, industrial equipment and other fields. After more than 20 years of continuous R&D, technological innovation, market development and application services, technical level and the scale of production and sales have been on the forefront of the industry. Hytek has been committed to helping the development of subdivided industries with innovative hydraulic technology, "focusing on the challenges and pressures of customers, providing competitive products and solutions, reducing costs and increasing efficiency for customers, and continuously creating maximum value".

Product Series

-  Open Circuit Pump
-  Closed Circuit Pump
-  Fixed Displacement Motor
-  Variable Displacement Motor
-  Hydrostatic Transmission Unit
-  Internal Gear Pump
-  Vane Pump
-  Proportional valve/
Industrial Hydraulic Valve

For more information,
please visit our official website and social media:en.hytek.cn



@Hytek Power

HYTEK POWER CO.,LTD.

No. 99,Shengyuan Road,Tengqiao Town,Lucheng District,Wenzhoucity 325029,Zhejiang,CHINA
Email: globalsales@hytek.cn

America Canada Germany Italy Russia Türkiye Australia South Korea Thailand India Indonesia South Africa

HYTEK-REV1.0 04/2026
If there are any other modifications,no further notice will be given.