



Internal Gear Pump HG

HG series internal gear pumps manifesting the high efficiency and low energy consumption of servo VFD systems are widely used on such industrial machinery as plastics machinery, shoe machinery, diecasting machinery and forklift. It is particularly suitable for the energy saving system of servo VFDs.

It is designed and developed to meet high pressure and high speed requirements of servo VFDs. The internal oil passages are further optimized based on suction and discharge flow analysis in high-speed high-pressure working conditions, and the dynamic stability of the pressure compensation mechanism is improved to enhance reliability of the products.

Displacement: 8-180 ml/r
Max. pressure: 350 bar
Max. speed: 3000 r/min
Min. speed: 200 r/min



Features



- Axial and radial pressure compensation is designed to keep high volume efficiency even at low speed and low viscosity
- Suitable for such operations as 1/2-quadrant, pressure holding and start/stop
- High-strength cast iron and unique inner noise reduction design for lower noise
- Extremely low flow and pressure fluctuation so that stable flow and pressure output can be kept even at low speed
- Insensitive to oil contamination & long life
- Through-drive available

Contents



● Model Code Single Pump.....	02
● Structure.....	03
● Technical Data.....	03
● Characteristic Curve.....	05
● Installation Dimensions,HG0.....	06
● Installation Dimensions,HG1.....	07
● Installation Dimensions,HG2.....	08
● Port Flange Dimensions.....	09
● Model Code Double Pump.....	10
● Installation Dimensions,HG00.....	12
● Installation Dimensions,HG10.....	13
● Installation Dimensions,HG11.....	14
● Installation Dimensions,HG21.....	15
● Installation Dimensions,HG22.....	16
● Port Flange Dimensions.....	17
● Installation Instructions.....	18



> Model Code

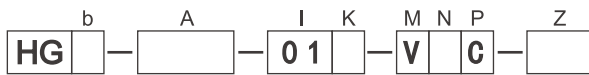

Pump type

—	Internal gear pump	HG
---	--------------------	----

Frame size

b	Size: 8...25	0
	Size: 25...63	1
	Size: 63...180	2

Displacement

A	Frame 0, Geometric displacement, ml/r	08	10	13	16	20	25
	Frame 1, Geometric displacement, ml/r		25	32	40	50	63
	Frame 2, Geometric displacement, ml/r	63	80	100	125	145	160

Series

I	Series 01	01
---	-----------	----

Direction of rotation

K		HG0	HG1	HG2	
	Clockwise(CW)	●	●	●	R
	Counterclockwise (CCW)	—	—	●	L

Sealing material

M		HG0	HG1	HG2	
	NBR seal + FKM Shaft seal	●	●	●	N
	NBR seal + NBR Shaft seal	●	●	●	P
	FKM seal + FKM Shaft seal	●	●	●	V

Drive shaft

N		HG0	HG1	HG2	
	Parallel keyed shaf DIN 6885	●	●	●	P
	Splined shaf ANSI B92.1	●	●	●	S

Mounting flange

P	2 holes, SAE J744	C
---	-------------------	---

Special configuration

Z		HG0	HG1	HG2	
		●	—	—	
	Reinforced locating pin	—	●	●	36

● Available ○ On request — Not available ■ Recommended model



> Structure

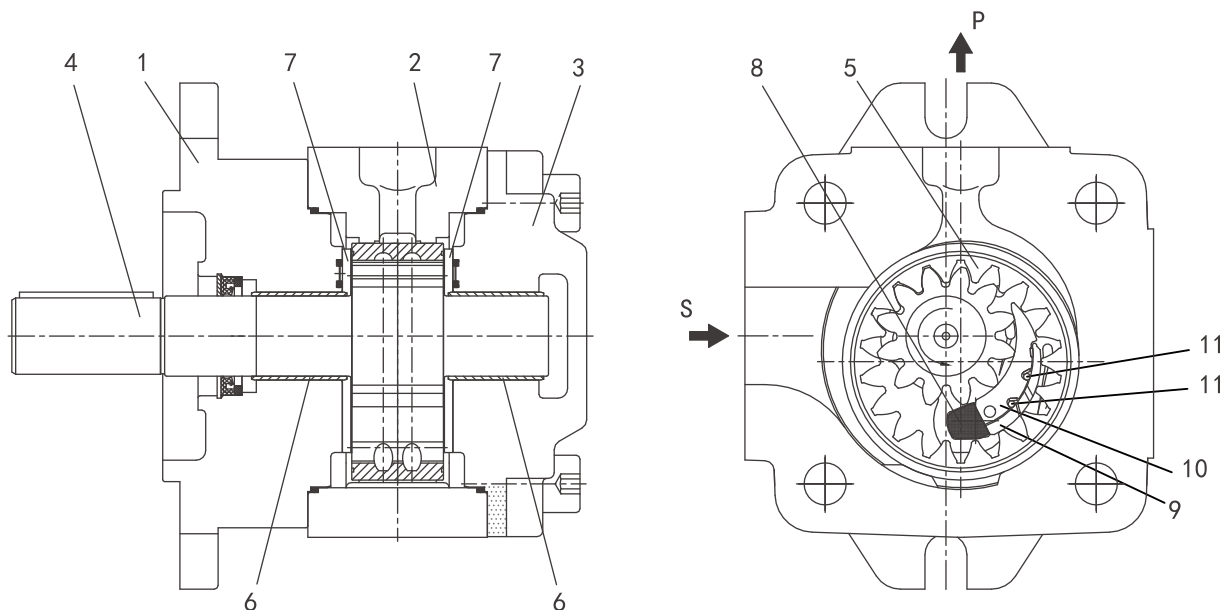

HG series hydraulic pumps are internal gear pumps with fixed displacement and clearance compensation.

Basic structure: 1- front body; 2- middle housing; 3- rear cover; 4- shaft bearing; 5- annular gear; 6- sliding bearing; 7- front and rear side plates; 8- locating rod; 9- crescent side plate; 10- crescent main plate; 11- plastic rod

> Technical Data

Design	Internal gear pump with clearance compensation
Type of connection	2-hole flange SAE J744
Pipe connection	Flange connection
Shaft load	Only radial and axial forces obtained through consultation (e.g. on belt pulley)
Rotation direction (from shaft end)	CW and CCW (as required) - not upside down
Hydraulic fluid	Petroleum base mineral oil with viscosity within the range of 10-300 mm ² /s; ISO VG46 anti-wear hydraulic oil is recommended
Temperature range	Working temperature range: -10 °C-100 °C; to ensure long-term reliable operation, the optimal working temperature range is 20 °C-80 °C.
Cleanliness control	Oil cleanliness of the control system should not exceed code 9 (NAS 1638) or 17/14 (ISO 4066).
Suction port pressure	Allowable absolute pressure at suction inlet: 0.8-2 bar



> HG Series Single Pump

HG0 Displacement: 8. . . 25

HG1 Displacement: 25. . . 63

HG2 Displacement: 63. . . 180



> Technical Data

Series		HG0					
Size		8	10	13	16	20	25
Weight	m kg	4.6	4.8	4.9	5.2	5.6	6
Speed	n_{min} r/min	600	600	600	600	600	600
	n_{max} r/min	3000	3000	3000	3000	3000	3000
Displacement	V cm ³	8.2	10.2	13.3	16.0	20.0	24.0
Working pressure	Rated MPa	31.5	31.5	31.5	31.5	25	25
	Max. MPa(10s duration)	35	35	35	35	30	30

Series		HG1				
Size		25	32	40	50	63
Weight	m kg	14.5	15	16	17	18.5
Speed	n_{min} r/min	200	200	200	200	200
	n_{max} r/min	3000	3000	3000	3000	3000
Displacement	V cm ³	25.3	32.7	40.1	50.7	63.7
Working pressure	Rated MPa	31.5	31.5	31.5	31.5	25
	Max. MPa(10s duration)	35	35	35	35	30

Series		HG2						
Size		63	80	100	125	145	160	180
Weight	m kg	42	43.5	45.5	48	50	52	53.5
Speed	n_{min} r/min	200	200	200	200	200	200	200
	n_{max} r/min	3000	3000	3000	3000	3000	3000	3000
Displacement	V cm ³	64.7	81.4	100.2	125.3	145.2	162.8	180.5
Working pressure	Rated MPa	31.5	31.5	31.5	31.5	25	21	19
	Max. MPa(10s duration)	35	35	35	35	28	26	23



> Characteristic Curve

Flow and pressure features (test conditions: $n=1450\text{r/min}$, $V=46\text{mm}^3/\text{s}$, $t=50^\circ\text{C}$)

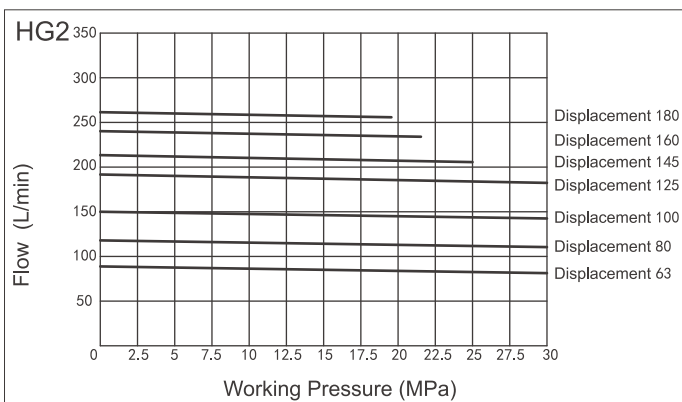
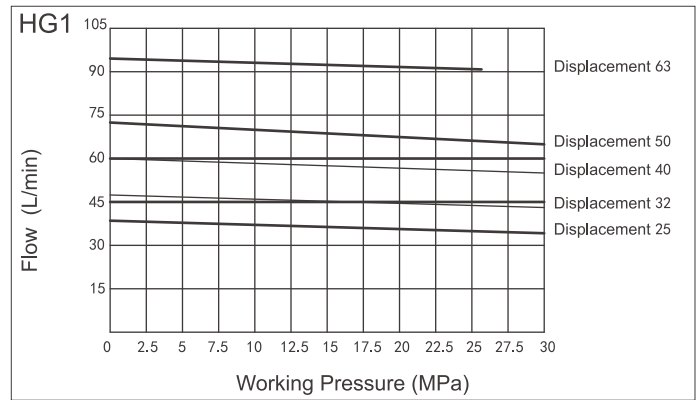
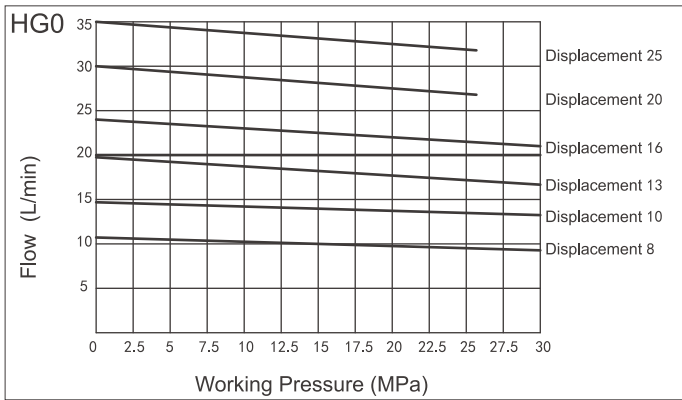

Noise and pressure features (test conditions: $n=1450\text{r/min}$, $V=46\text{mm}^3/\text{s}$, $t=50^\circ\text{C}$, distance from detector to pump=1 m)

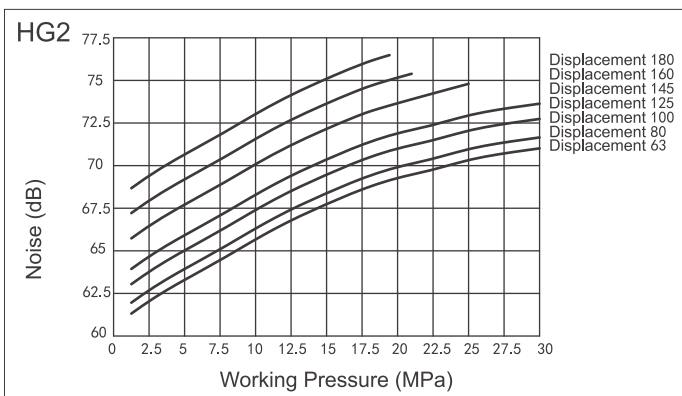
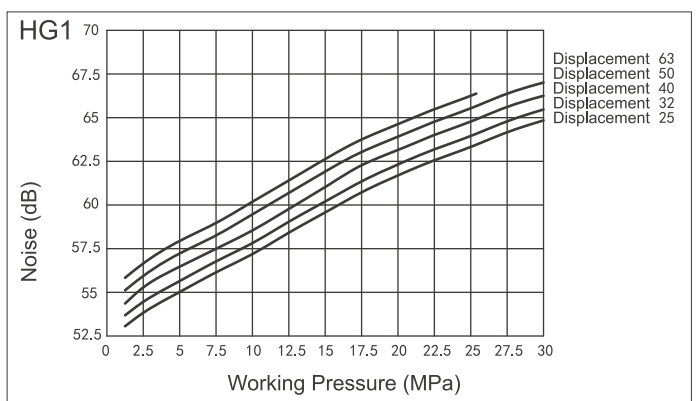
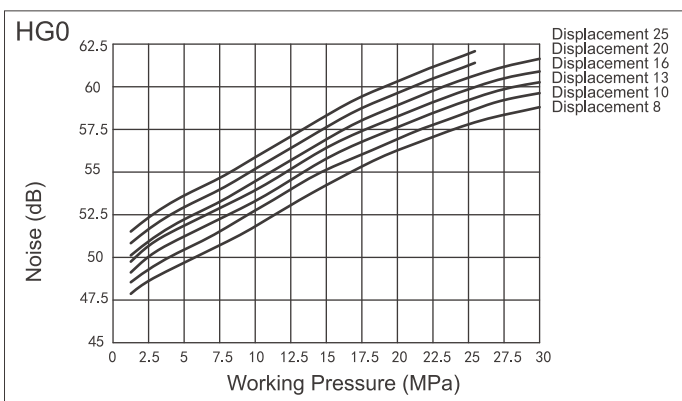



► Installation Dimensions (Unit:mm)

HG0-※-01R-VPC (Parallel keyed shaft)

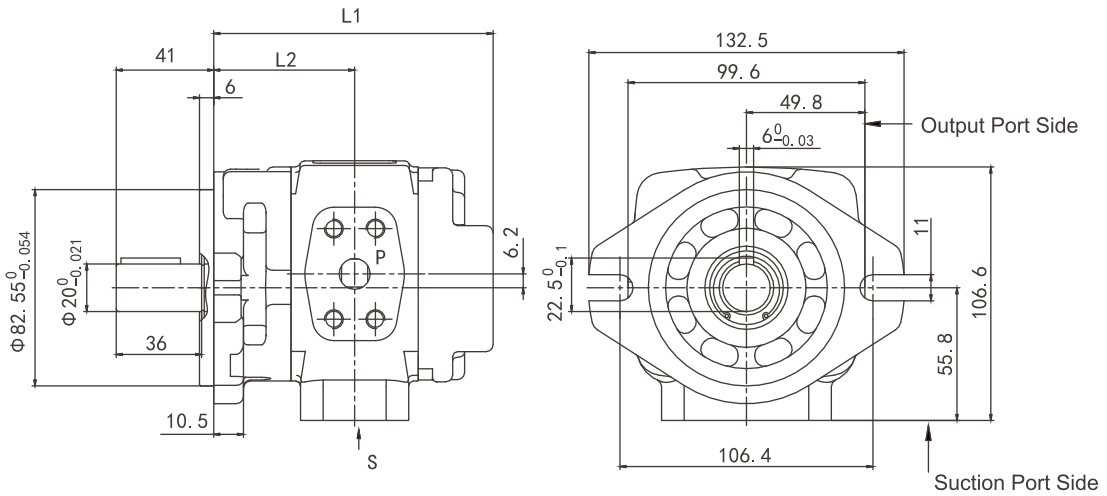

Model	L1	L2	S	P
HG0-08-01R-VPC	107	54	$\Phi 19$	$\Phi 13$
HG0-10-01R-VPC	111	56		
HG0-13-01R-VPC	117.5	59.25		
HG0-16-01R-VPC	123	62	$\Phi 26$	$\Phi 18$
HG0-20-01R-VPC	131	66	$\Phi 28$	$\Phi 19$
HG0-25-01R-VPC	139	70		

HG0-※-01R-VSC (Splined shaft)

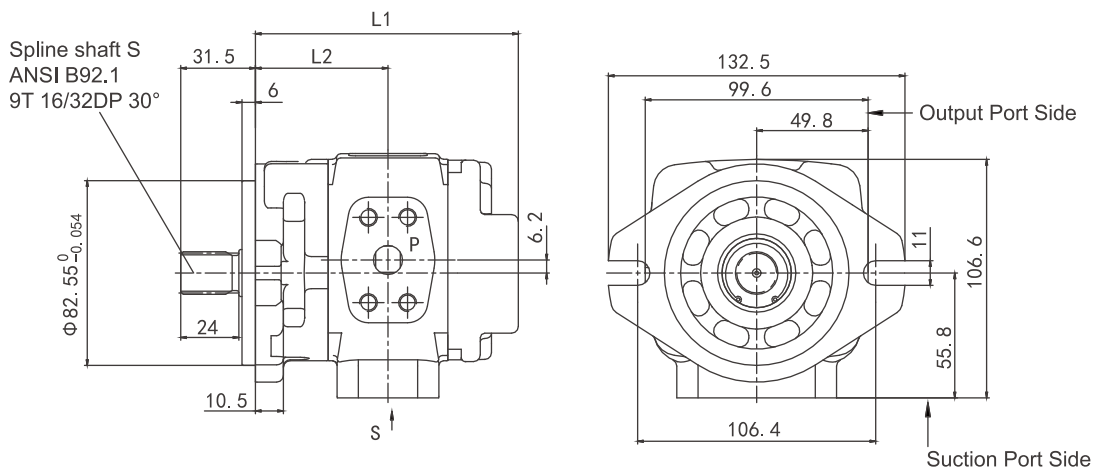

Model	L1	L2	S	P
HG0-08-01R-VSC	107	54	$\Phi 19$	$\Phi 13$
HG0-10-01R-VSC	111	56		
HG0-13-01R-VSC	117.5	59.25		
HG0-16-01R-VSC	123	62	$\Phi 26$	$\Phi 18$
HG0-20-01R-VSC	131	66	$\Phi 28$	$\Phi 19$
HG0-25-01R-VSC	139	70		



► Installation Dimensions (Unit:mm)

HG1-※-01R-VPC (Parallel keyed shaft)

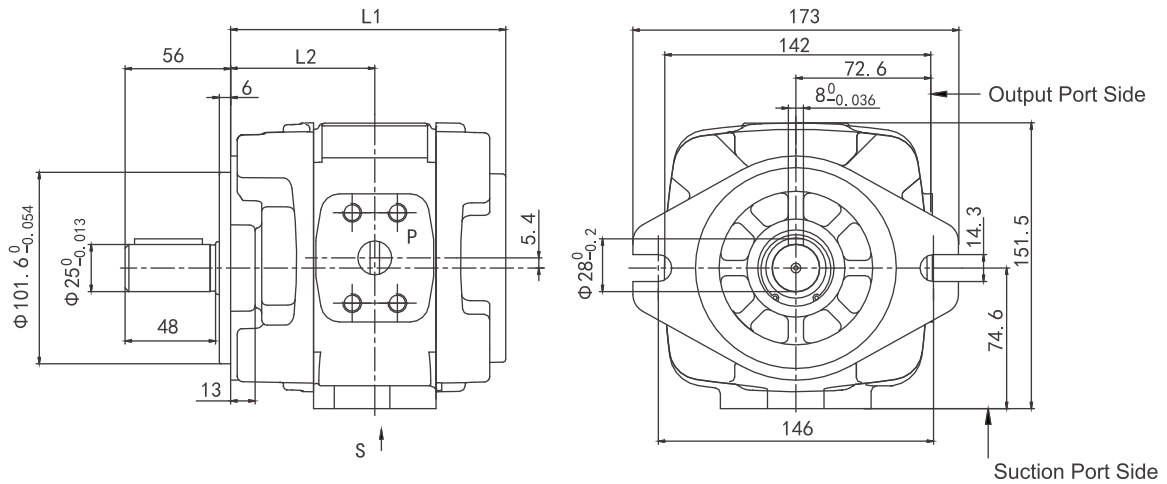

Model	L1	L2	S	P
HG1-25-01R-VPC-36	139	73	Φ 32	Φ 18
HG1-32-01R-VPC-36	146	76.5		
HG1-40-01R-VPC-36	153	80		Φ 20
HG1-50-01R-VPC-36	163	85		
HG1-63-01R-VPC-36	177	92		

HG1-※-01R-VSC (Spline shaft)

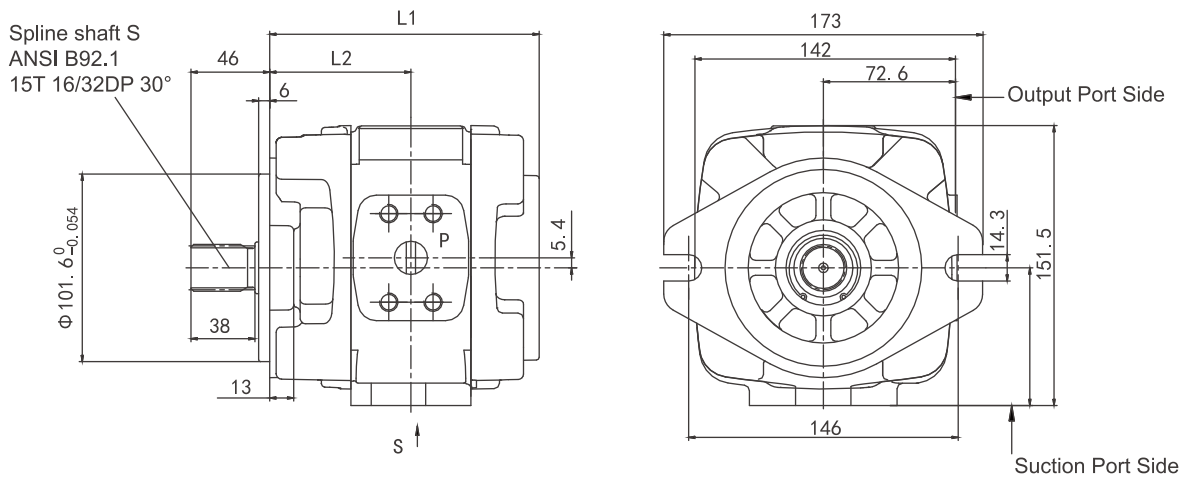

Model	L1	L2	S	P
HG1-25-01R-VSC-36	139	73	Φ 32	Φ 18
HG1-32-01R-VSC-36	146	76.5		
HG1-40-01R-VSC-36	153	80		Φ 20
HG1-50-01R-VSC-36	163	85		
HG1-63-01R-VSC-36	177	92		



► Installation Dimensions (Unit:mm)

HG2-※-01R-VPC (Parallel keyed shaft)

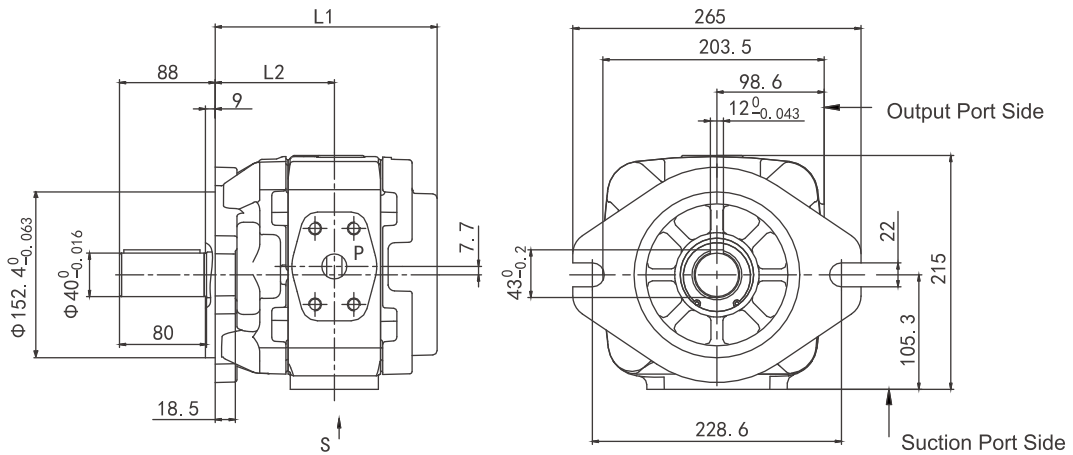

Model	L1	L2	S	P
HG2-63-01R-VPC-36	196	105.5	$\Phi 40$	$\Phi 23$
HG2-80-01R-VPC-36	204	109.5	$\Phi 51$	$\Phi 32$
HG2-100-01R-VPC-36	213	114		
HG2-125-01R-VPC-36	225	120	$\Phi 63.5$	$\Phi 38$
HG2-145-01R-VPC-36	235.5	124.75		
HG2-160-01R-VPC-36	243	129	$\Phi 76$	
HG2-180-01R-VPC-36	251.5	133.25		

HG2-※-01R-VSC (Spline shaft)

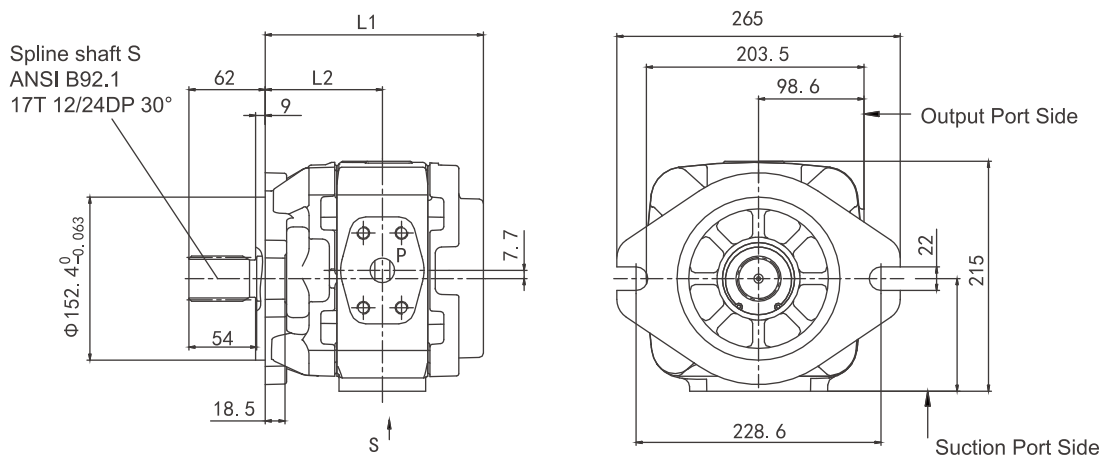

Model	L1	L2	S	P
HG2-63-01R-VSC-36	196	105.5	$\Phi 40$	$\Phi 23$
HG2-80-01R-VSC-36	204	109.5	$\Phi 51$	$\Phi 32$
HG2-100-01R-VSC-36	213	114		
HG2-125-01R-VSC-36	225	120	$\Phi 63.5$	$\Phi 38$
HG2-145-01R-VSC-36	235.5	124.75		
HG2-160-01R-VSC-36	243	129	$\Phi 76$	
HG2-180-01R-VSC-36	251.5	133.25		



➤ Port Flange Dimensions (Unit:mm)

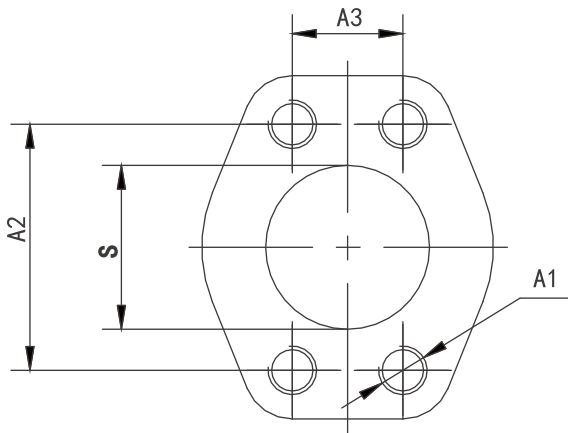

Suction Port "S"

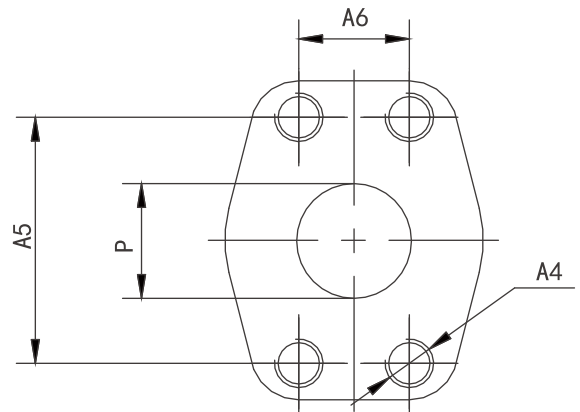

Output Port "P"

Series	Size	S	A1	A2	A3	P	A4	A5	A6
HG0	8	Φ 19	M10, 15 deep	47.6	22.2	Φ 13	M8, 13 deep	38.1	17.5
	10			52.4	26.2				
	13								
	16								
	20	Φ 26		58.7	30.2	Φ 18	M10, 15 deep	47.6	22.2
	25	Φ 28							
HG1	25	Φ 32	M10, 17 deep	58.7	30.2	Φ 18	M10, 17 deep	47.6	22.2
	32								
	40					Φ 20		52.4	26.2
	50								
	63								
HG2	63	Φ 40	M12, 20 deep	69.9	35.7	Φ 23	M10, 17 deep	52.4	26.2
	80	Φ 50		77.8	42.9	Φ 32	M12, 20 deep	69.9	35.7
	100								
	125	Φ 63.5		88.9	50.8	Φ 38	M16, 25 deep	79.4	36.5
	145								
	160	Φ 76		M16, 25 deep	106.4				
	180								



> HG Series Double Pump

HG00/HG10/HG11/HG21/HG22 Series

A double pump is a combination of two single pumps which are connected in series and have one shared input port and two output ports connecting two separate loops. The combination of different pump series can realize different displacements.



> Model Code

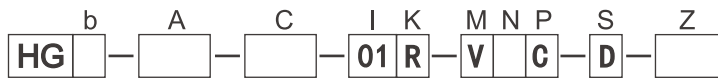

Pump type

—	Internal gear pump	HG
---	--------------------	----

Frame size

b	Front	Size:8. . . 25	0
		Size:25. . . 63	1
		Size:63. . . 160	2
	Rear	Size:8. . . 25	0
		Size:25. . . 63	1
		Size:63. . . 160	2

Displacement

A	Front	Frame 0,Geometric displacement,ml/r	08	10	13	16	20	25
		Frame 1,Geometric displacement,ml/r		25	32	40	50	63
		Frame 2,Geometric displacement,ml/r	63	80	100	125	145	160
C	Rear	Frame 0,Geometric displacement,ml/r	08	10	13	16	20	25
		Frame 1,Geometric displacement,ml/r		25	32	40	50	63
		Frame 2,Geometric displacement,ml/r	63	80	100	125	145	160

Series

I	Series 01	01
---	-----------	----

Direction of rotation

K	Clockwise (CW)	R
---	----------------	---



➤ Model Code

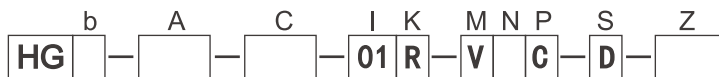

Sealing material

		HG00	HG10	HG11	HG21	HG22	
M	NBR seal + FKM Shaft seal	●	●	●	●	●	N
	NBR seal + NBR Shaft seal	●	●	●	●	●	P
	FKM seal + FKM Shaft seal	●	●	●	●	●	V

Drive shaft

		HG00	HG10	HG11	HG21	HG22	
N	Parallel keyed shaf DIN 6885	●	●	●	●	●	P
	Splined shaf ANSI B92.1	●	●	●	●	●	S

ounting flange

P	2 holes,SAE J744						C
---	------------------	--	--	--	--	--	---

Intermediate body

S	Newly designed intermediate body						D
---	----------------------------------	--	--	--	--	--	---

Special configuration

		HG00	HG10	HG11	HG21	HG22	
Z		●	—	—	—	—	
	Reinforced locating pin	—	●	●	●	●	36

● Available ○ On request — Not available ■ Recommended model



➤ Installation Dimensions (Unit:mm)

HG00-※-※-01R-VPC (Parallel keyed shaf P)

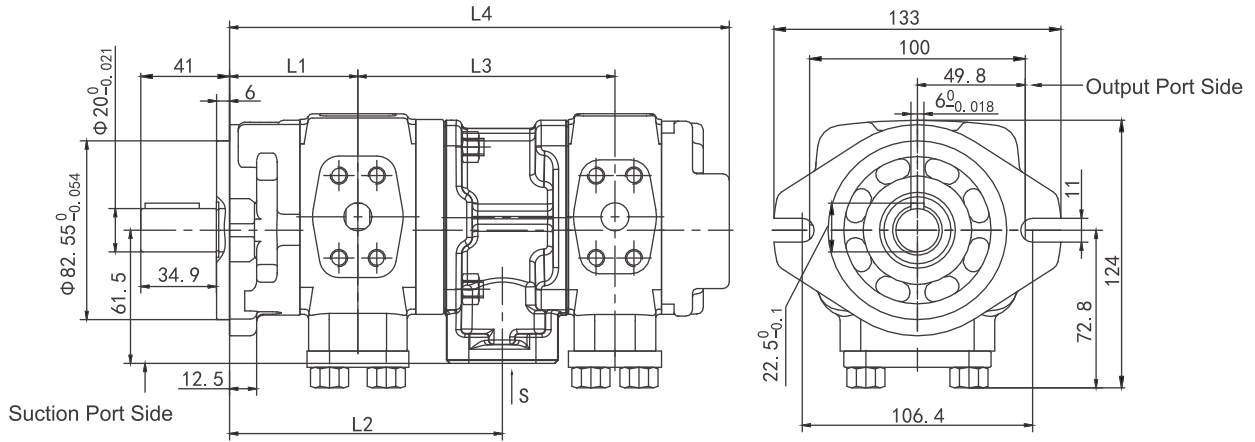

Model	L1	L2	Rear Pump Size												
			08		10		13		16		20				
			L3	L4	L3	L4	L3	L4	L3	L4	L3	L4			
HG00-08-※-01R-VPC	54	115.5	113.5	220.3											
HG00-10-※-01R-VPC	56	119.5	115.5	224.3	117.5	228.3									
HG00-13-※-01R-VPC	59.25	126	118.75	230.8	120.75	234.8	124	241.3							
HG00-16-※-01R-VPC	62	131.5	121.5	236.3	123.5	240.3	126.75	246.8	129.5	252.3					
HG00-20-※-01R-VPC	66	139.5	125.5	244.3	127.5	248.3	130.75	254.8	133.5	260.3	137.5	268.3			

HG00-※-※-01R-VSC (Splined shaf S)

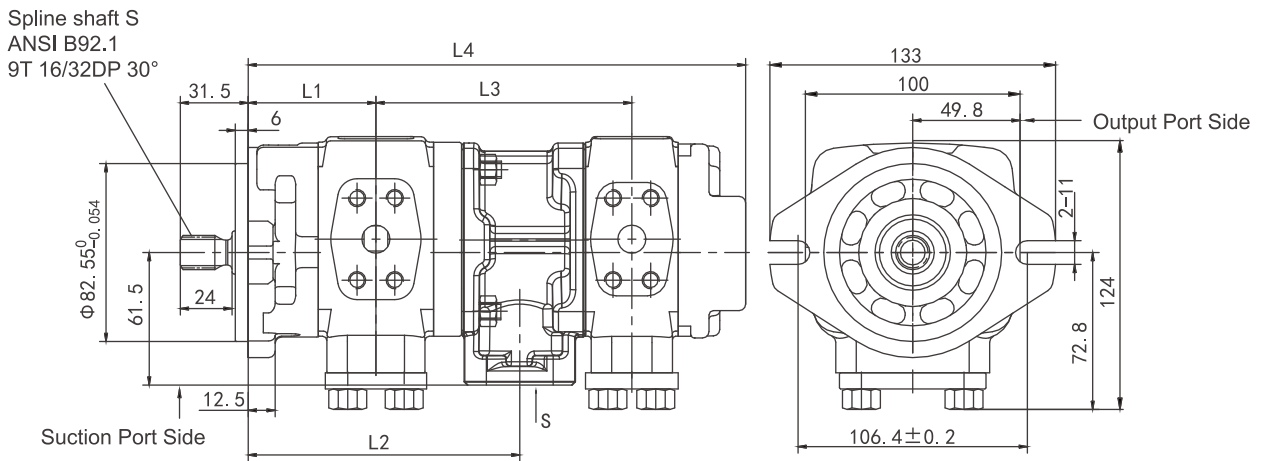

Model	L1	L2	Rear Pump Size												
			08		10		13		16		20				
			L3	L4	L3	L4	L3	L4	L3	L4	L3	L4			
HG00-08-※-01R-VSC	54	115.5	113.5	220.3											
HG00-10-※-01R-VSC	56	119.5	115.5	224.3	117.5	228.3									
HG00-13-※-01R-VSC	59.25	126	118.75	230.8	120.75	234.8	124	241.3							
HG00-16-※-01R-VSC	62	131.5	121.5	236.3	123.5	240.3	126.75	246.8	129.5	252.3					
HG00-20-※-01R-VSC	66	139.5	125.5	244.3	127.5	248.3	130.75	254.8	133.5	260.3	137.5	268.3			



► Installation Dimensions (Unit:mm)

HG10-※-※-01R-VPC-D (Parallel keyed shaf P)

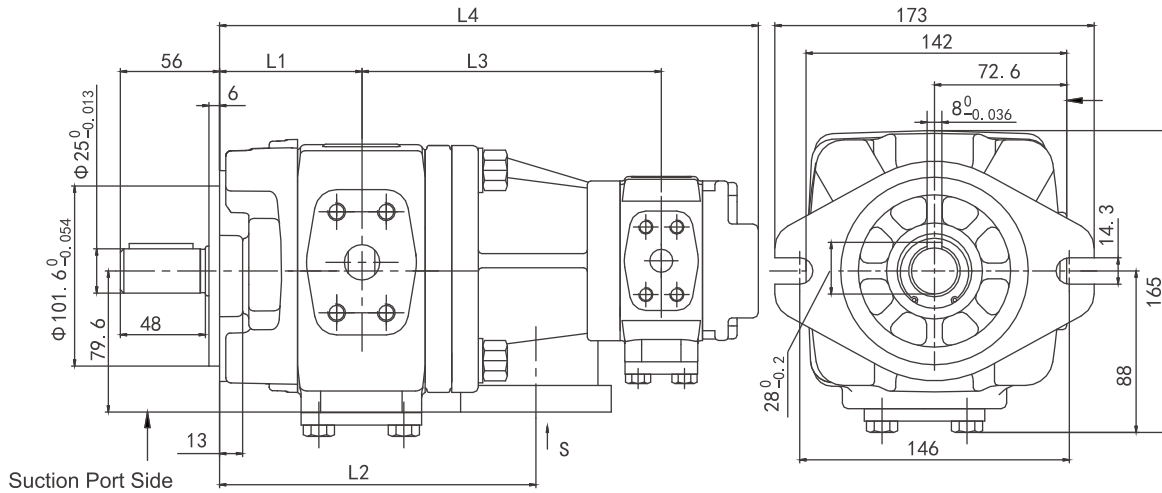

Model	L1	L2	Rear Pump Size											
			08		10		13		16		20		25	
			L3	L4	L3	L4	L3	L4	L3	L4	L3	L4	L3	L4
HG10-25-※-01R-VPC-D-36	73	153.5	138.5	264.5	140.5	268.5	143.8	275	146.5	280.5	150.5	288.5	154.5	296.5
HG10-32-※-01R-VPC-D-36	76.5	160.5	142	271.5	144	275.5	147.3	282	150	287.5	154	295.5	158	303.5
HG10-40-※-01R-VPC-D-36	80	167.5	145.5	278.5	147.5	282.5	150.8	289	153.5	294.5	157.5	302.5	161.5	310.5
HG10-50-※-01R-VPC-D-36	85	177.5	150.5	288.5	152.5	292.5	155.8	299	158.5	304.5	162.5	312.5	166.5	320.5
HG10-63-※-01R-VPC-D-36	92	191.5	157.5	302.5	159.5	306.5	162.8	313	165.5	318.5	169.5	326.5	173.5	334.5

HG10-※-※-01R-VSC-D (Splined shaf S)

Spline shaft S
ANSI B92.1
15T 16/32DP 30°

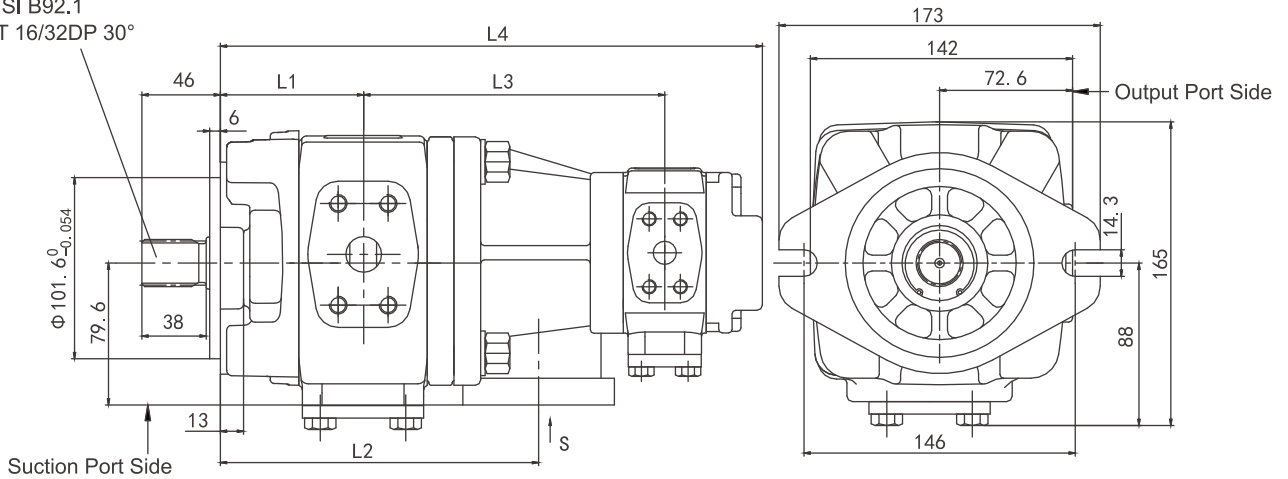

Model	L1	L2	Rear Pump Size											
			08		10		13		16		20		25	
			L3	L4	L3	L4	L3	L4	L3	L4	L3	L4	L3	L4
HG10-25-※-01R-VSC-D-36	73	153.5	138.5	264.5	140.5	268.5	143.8	275	146.5	280.5	150.5	288.5	154.5	296.5
HG10-32-※-01R-VSC-D-36	76.5	160.5	142	271.5	144	275.5	147.3	282	150	287.5	154	295.5	158	303.5
HG10-40-※-01R-VSC-D-36	80	167.5	145.5	278.5	147.5	282.5	150.8	289	153.5	294.5	157.5	302.5	161.5	310.5
HG10-50-※-01R-VSC-D-36	85	177.5	150.5	288.5	152.5	292.5	155.8	299	158.5	304.5	162.5	312.5	166.5	320.5
HG10-63-※-01R-VSC-D-36	92	191.5	157.5	302.5	159.5	306.5	162.8	313	165.5	318.5	169.5	326.5	173.5	334.5



► Installation Dimensions (Unit:mm)

HG11-※-※-01R-VPC-D (Parallel keyed shaf P)

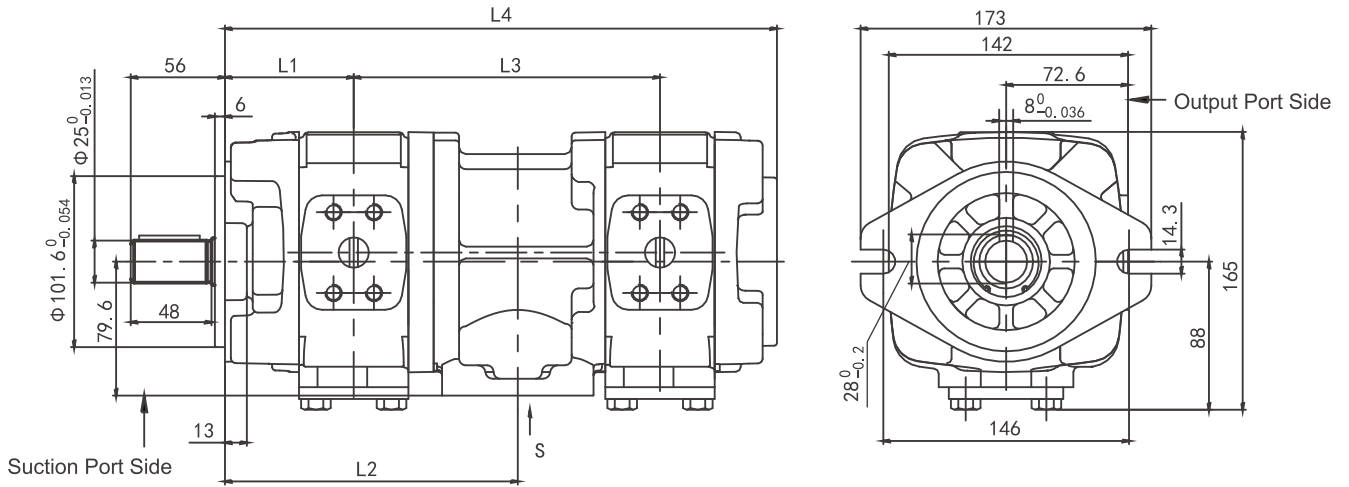

Model	L1	L2	Rear Pump Size												
			25		32		40		50		63				
			L3	L4	L3	L4	L3	L4	L3	L4	L3	L4			
HG11-25-※-01R-VPC-D-36	73	161	161	300											
HG11-32-※-01R-VPC-D-36	76.5	168	164.5	307	168	314									
HG11-40-※-01R-VPC-D-36	80	175	168	314	171.5	321	175	328							
HG11-50-※-01R-VPC-D-36	85	185	173	324	176.5	331	180	338	185	348					
HG11-63-※-01R-VPC-D-36	92	199	180	338	183.5	345	187	352	192	362	199	376			

HG11-※-※-01R-VSC-D (Splined shaf S)

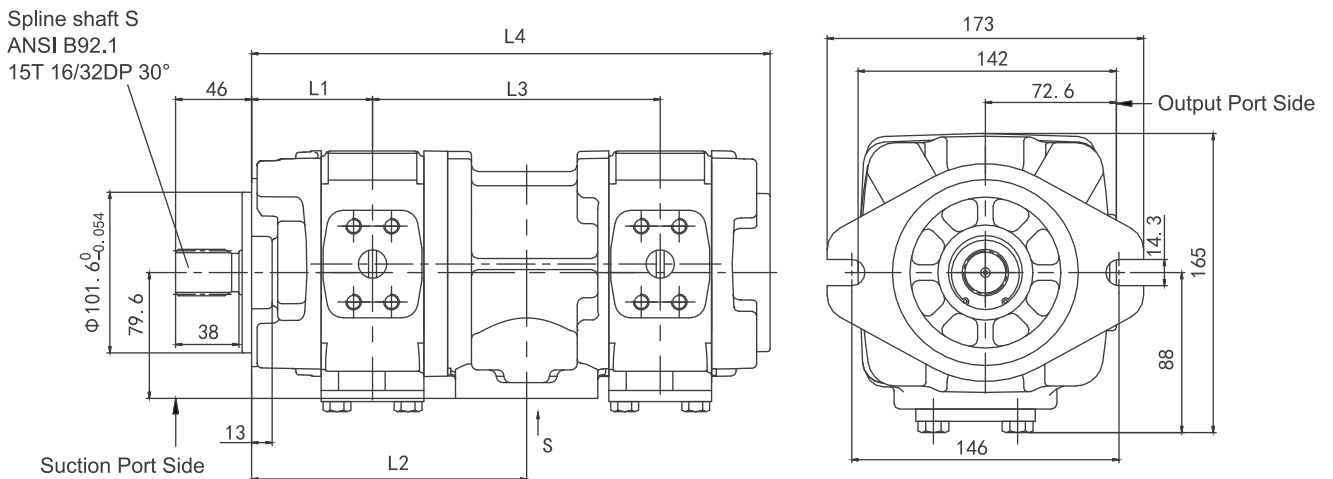

Model	L1	L2	Rear Pump Size												
			25		32		40		50		63				
			L3	L4	L3	L4	L3	L4	L3	L4	L3	L4			
HG11-25-※-01R-VSC-D-36	73	161	161	300											
HG11-32-※-01R-VSC-D-36	76.5	168	164.5	307	168	314									
HG11-40-※-01R-VSC-D-36	80	175	168	314	171.5	321	175	328							
HG11-50-※-01R-VSC-D-36	85	185	173	324	176.5	331	180	338	185	348					
HG11-63-※-01R-VSC-D-36	92	199	180	338	183.5	345	187	352	192	362	199	376			



➤ Installation Dimensions (Unit:mm)

HG21-※-※-01R-VPC-D (Parallel keyed shaf P)

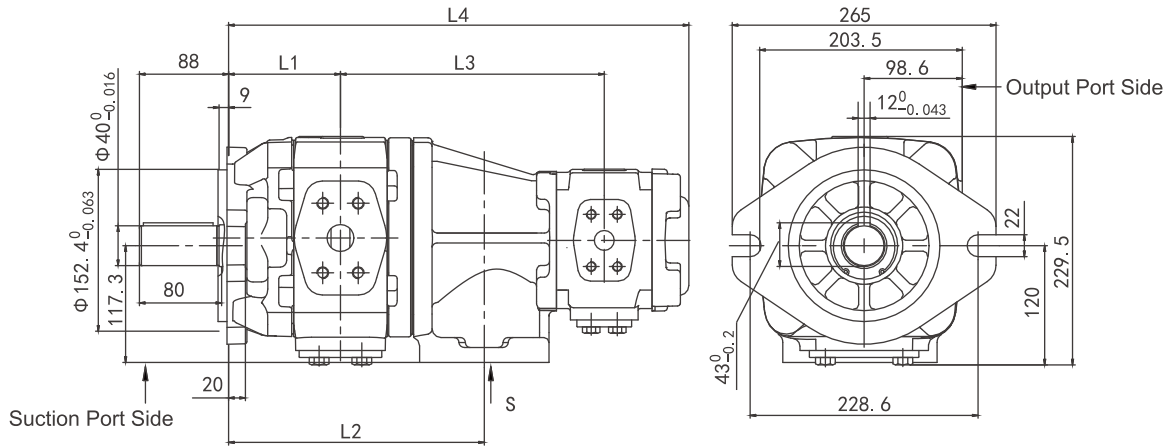

Model	L1	L2	Rear Pump Size									
			25		32		40		50		63	
			L3	L4	L3	L4	L3	L4	L3	L4	L3	L4
HG21-63-※-01R-VPC-D-36	105.5	223	200.5	372	204	379	207.5	386	212.5	396	219.5	410
HG21-80-※-01R-VPC-D-36	109.5	231	204.5	380	208	387	211.5	394	216.5	404	223.5	418
HG21-100-※-01R-VPC-D-36	114	240	209	389	212.5	396	216	403	221	413	228	427
HG21-125-※-01R-VPC-D-36	120	252	215	401	218.5	408	222	415	227	425	234	439
HG21-145-※-01R-VPC-D-36	124.8	261.5	219.8	410.5	223.3	417.5	226.8	424.5	231.8	434.5	238.8	448.5
HG21-160-※-01R-VPC-D-36	129	270	224	419	227.5	426	231	433	236	443	243	457

HG21-※-※-01R-VSC-D (Splined shaf S)

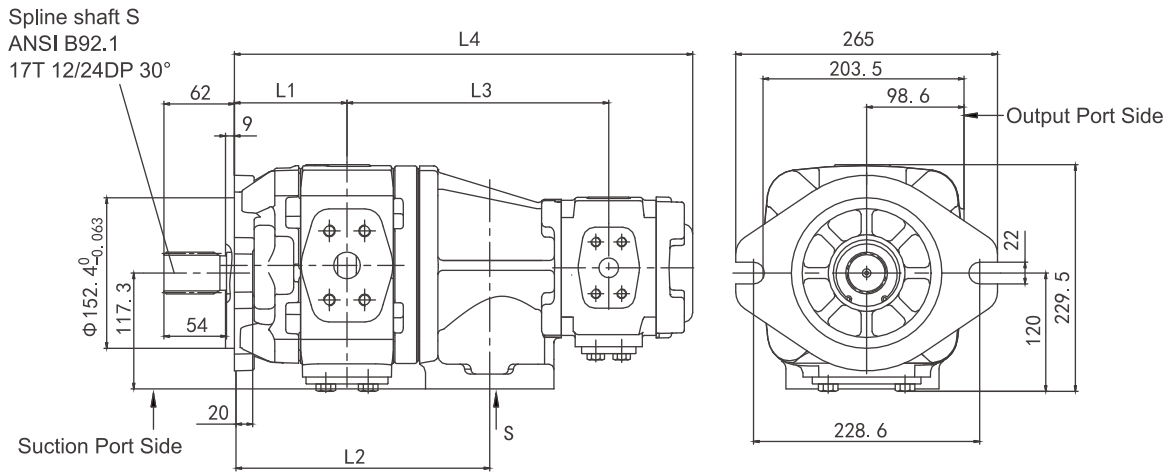

Model	L1	L2	Rear Pump Size									
			25		32		40		50		63	
			L3	L4	L3	L4	L3	L4	L3	L4	L3	L4
HG21-63-※-01R-VPC-D-36	105.5	223	200.5	372	204	379	207.5	386	212.5	396	219.5	410
HG21-80-※-01R-VPC-D-36	109.5	231	204.5	380	208	387	211.5	394	216.5	404	223.5	418
HG21-100-※-01R-VPC-D-36	114	240	209	389	212.5	396	216	403	221	413	228	427
HG21-125-※-01R-VPC-D-36	120	252	215	401	218.5	408	222	415	227	425	234	439
HG21-145-※-01R-VPC-D-36	124.8	261.5	219.8	410.5	223.3	417.5	226.8	424.5	231.8	434.5	238.8	448.5
HG21-160-※-01R-VPC-D-36	129	270	224	419	227.5	426	231	433	236	443	243	457



➤ Port Flange Dimensions (Unit:mm)

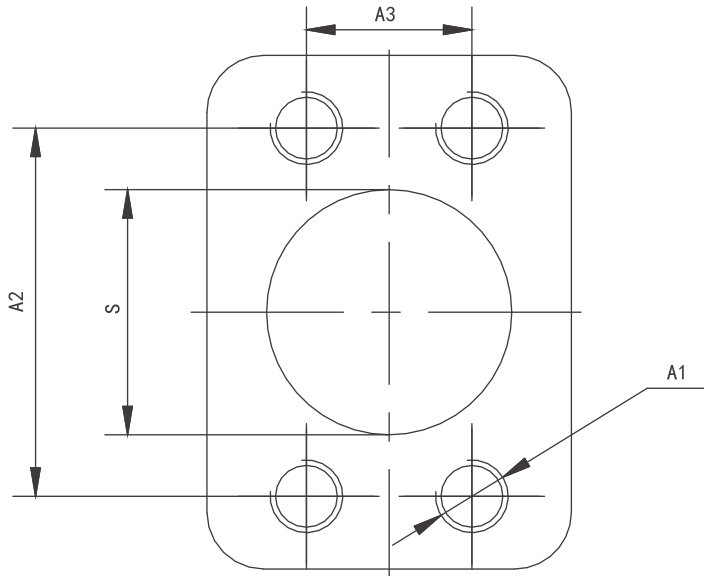

Double Pump Suction Port "S"

Series	S	A1	A2	A3
HG00	Φ 32	M10, 17 deep	58.7	30.2
HG10	Φ 38	M12, 20 deep	69.9	35.7
HG11	Φ 51		77.8	42.9
HG21	Φ 76	M16, 25 deep	106.4	61.9
HG22	Φ 89		120.7	69.9



> Installation Instructions

1. Drive Mechanism

Motor + Bell guard + Coupling + Pump

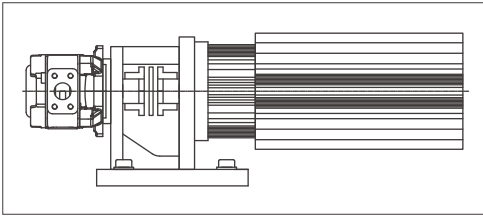

- The pump is not allowed to apply axial and radial forces on the drive shaft!
- The axes of the motor and the pump must be properly aligned!
- Always use a coupling that can realize compensation for shaft misalignment!
- Avoid axial force and the use of knocking tools when installing the coupling!
- Gently knock on the soft pad based on the fit tolerance of coupling!

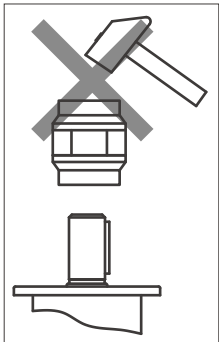

2. Installation

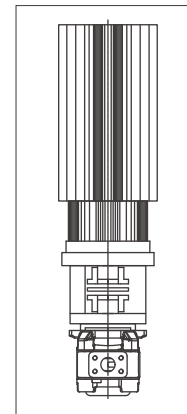
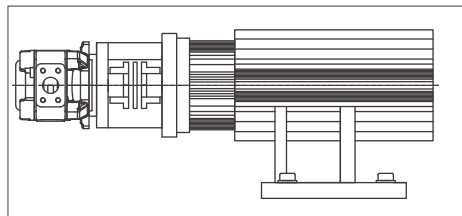
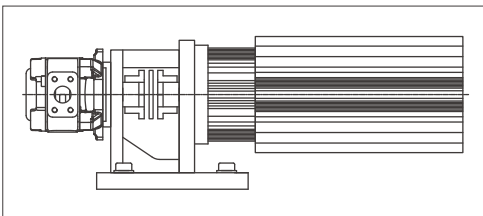

3. Preparations

- Check whether the equipment is installed in a careful and clean manner.
- Use only the filter with the required minimum filter rating for oil filling.
- Fill the pump with oil through the suction line or pressure line.
- Check consistency of motor direction with pump direction based on the pump model.

4. Air Bleeding

- Manually open the air vent on the equipment or turn on zero-pressure circulation according to user manual of the equipment. Make sure the trapped air is discharged under no pressure in the venting process.
- Shortly start and promptly stop (inching) the motor to discharge air in the pump. Repeat this process until air in the pump is completely discharged.
- Close the manually opened air vent.



Since 2002

Over twenty years of deep cultivation in the field of hydraulic Solutions

HYTEK is a high technology enterprise integrating R&D, production, sales and service of hydraulic power products. Provides professional hydraulic transmission control products and solutions for construction machinery, road machinery, material handling machinery, agricultural and forestry machinery, industrial equipment and other fields. After more than 20 years of continuous R&D, technological innovation, market development and application services, technical level and the scale of production and sales have been on the forefront of the industry. Hytek has been committed to helping the development of subdivided industries with innovative hydraulic technology, "focusing on the challenges and pressures of customers, providing competitive products and solutions, reducing costs and increasing efficiency for customers, and continuously creating maximum value".

Product Series

- Open Circuit Pump
- Closed Circuit Pump
- Fixed Displacement Motor
- Variable Displacement Motor
- Hydrostatic Transmission Unit
- Internal Gear Pump
- Vane Pump
- Proportional valve/
Industrial Hydraulic Valve

For more information,
please visit our official website and social media:en.hytek.cn



@Hytek Power

HYTEK POWER CO.,LTD.

No. 99,Shengyuan Road,Tengqiao Town,Lucheng District,Wenzhoucity 325029,Zhejiang,CHINA
Email: globalsales@hytek.cn

America Canada Germany Italy Russia Türkiye Australia South Korea Thailand India Indonesia South Africa

HYTEK-REV1.0 04/2026
If there are any other modifications,no further notice will be given.