

Hydrostatic Transmission Unit HT S10 Series

HT Series Hydrostatic Transmission Unit is an integrated pump and motor unit developed for agricultural machinery sector, fully use driving performance of agricultural machinery, in order to meet the application requirement in harsh operating condition such as high speed and high pressure.

Displacement: 56 mL/r
Rated pressure: 32 MPa
Max pressure: 39 MPa

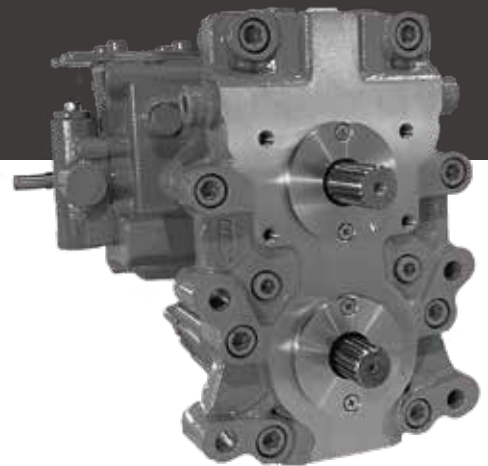

Features



- An integrated piston unit specially developed for agricultural machinery, enabling the full leverage of the operational performance of agricultural machinery.
- High volumetric efficiency, with output volumetric efficiency can exceed 90%.
- Output speed and displacement are proportionally and steplessly variable.
- Output speed increases from zero to maximum with the swash plate angle varies.
- Pump and motor integrated to one unit can efficiently minimize the need for piping layout.
- Compared to traditional split-type hydraulic pump and motor, it features lower pressure loss in pipelines.

Contents



● Module Code	02
● Structure	05
● Technical Data	07
● HW Mechanical Servo Control	08
● Installation Dimensions	09

> Modle Code



Hydrostatic Transmission

—	Swash plate type variable displacement pump			HT
---	---	--	--	----

Displacement

A	Geometric displacement in:mL/r	48	56	
---	--------------------------------	----	----	--

Variable Control Method

B		48	56	
	Mechanical servo control (without hand lever)	<input type="radio"/>	<input checked="" type="radio"/>	HW1
	Mechanical servo control (with cross handle)	<input type="radio"/>	<input checked="" type="radio"/>	HW2
	Mechanical servo control (with Z handle)	<input type="radio"/>	<input checked="" type="radio"/>	HW3
	Electric proportional control, 12V, Connector type: Deutsch DT04-2P	<input type="radio"/>	<input type="radio"/>	EP1
	Electric proportional control, 24V, Connector type: Deutsch DT04-2P	<input type="radio"/>	<input type="radio"/>	EP2

Brake Valve

D		48	56	
	Without brake value	<input type="radio"/>	<input checked="" type="radio"/>	0
	With brake valve, 12V, electrically released brake, connector type: Deutsch DT04-2P	<input type="radio"/>	<input type="radio"/>	1
	With brake valve, 24V, electrically released brake, connector type: Deutsch DT04-2P	<input type="radio"/>	<input type="radio"/>	2
	With brake valve, 12V, electrically held brake, connector type: Deutsch DT04-2P	<input type="radio"/>	<input type="radio"/>	3
	With brake valve, 24V, electrically held brake, connector type: Deutsch DT04-2P	<input type="radio"/>	<input type="radio"/>	4

Additional Features

E		48	56	
	No additional features	<input type="radio"/>	<input checked="" type="radio"/>	0

Series

H		48	56	
	Series S10	<input type="radio"/>	<input checked="" type="radio"/>	10

Direction of Rotation

J		48	56	
	CW	<input type="radio"/>	<input checked="" type="radio"/>	R
	CCW	<input type="radio"/>	<input checked="" type="radio"/>	L

Modle Code

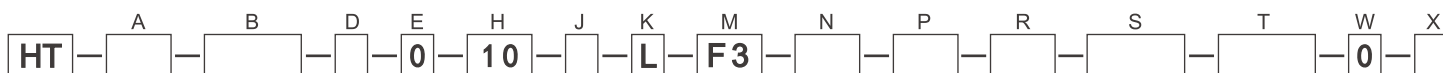

Position of Control Oylinder (Viewed from input shaft end)

K		48	56	
	the pump on top , the control cylinder on the left	○	●	L

Front Cover Type

M		48	56	
	Pump pilot flange ϕ 72mm, motor pilot flange ϕ 72mm, charge pump inlet port G1/2, pump mounting bolt hole spacing M8 x 92mm x 56mm.	○	●	F3

Pump Shaft Configuration

N		48	56	
	JIS D 2001, 20x18x1.25, Shaft extension length50	○	●	J1
	JIS D 2001, 20x18x1.25, Shaft extension length59	○	●	J2

Motor Shaft Configuration

P		48	56	
	JIS D 2001, 20x18x1.25, Shaft extension length: 37 mm, Snap ring groove location: 5 mm from shaft end face	○	●	J1
	JIS D 2001, 20x18x1.25, Shaft extension length 56mm, Snap ring groove located :5mm from shaft end face.	○	●	J2
	JIS D 2001, 20x18x1.25, Shaft extension length 56mm, Snap ring groove located :2.5mm from shaft end face.	○	●	J3
	JIS D 2001, 20x18x1.25, Shaft extension length 56.5mm, Snap ring groove located: 2.65mm from shaft end face.	○	●	J4

Charge Pump

R		48	56	
	Charge pump: counterclockwise rotation (CCW), displacement : 13.6 mL/r, inlet port : G3/4, outlet port : G1/2.	○	●	L1
	Charge pump: counterclockwise rotation (CCW), displacement: 13.6 mL/r, inlet port : G3/4, outlet port : G3/4.	○	○	L2
	Charge pump: clockwise rotation (CW), displacement : 13.6 mL/r, inlet port : G3/4, outlet port : G1/2.	○	●	R1
	Charge pump: clockwise rotation (CW), displacement : 13.6 mL/r, inlet port : G3/4, outlet port : G3/4.	○	●	R2

> Modle Code



High-pressure Relief Valve, left side (With the pump on top and viewed from the input shaft end, the relief valve is located on the left side)

		48	56	
S	Non-orificed high-pressure relief valve (opens at the set pressure to relieve flow).			**A
	High-pressure relief valve setting pressure: 39 MPa.	○	●	39A
	Orificed high-pressure relief valve.			**B
	High-pressure relief valve setting pressure: 39 MPa.	○	●	39B

High-pressure Relief Valve, right side (With the pump on top and viewed from the input shaft end, the relief valve is located on the right side)

		48	56	
T	Non-orificed high-pressure relief valve (opens at the set pressure to relieve flow).			**A
	High-pressure relief valve setting pressure: 39 MPa.	○	●	39A
	Orificed high-pressure relief valve.			**B
	High-pressure relief valve setting pressure: 39 MPa.	○	●	39B

Special Hardware Features

		48	56	
W	No special hardware features	○	●	0

Accessories

		48	56	
X	No accessories	○	●	0
	With external filte	○	○	A

● Available ○ On request — Not available ■ Recommended modle

> Structure

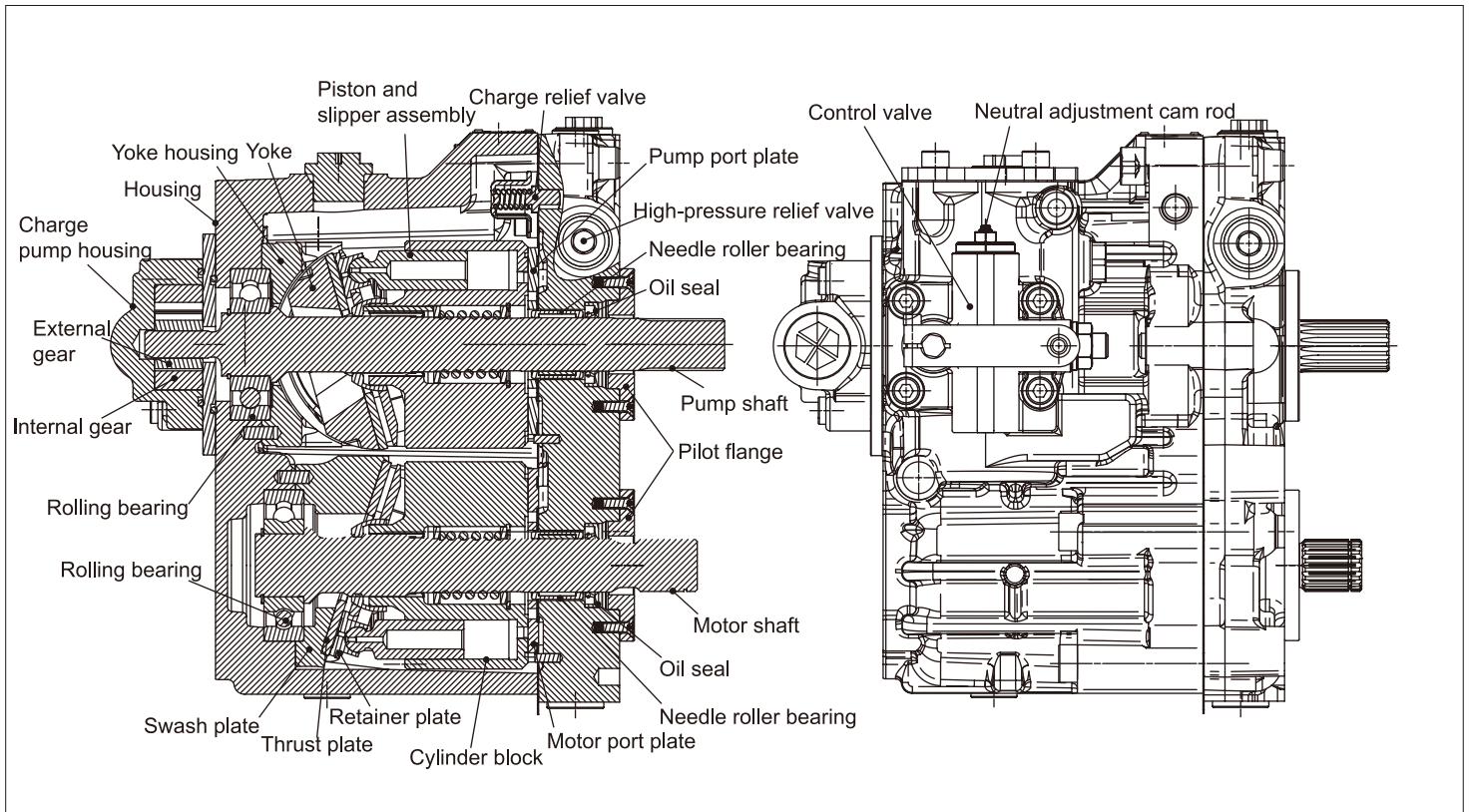

> Hydraulic Oil

Mineral oil

> Operating Viscosity Range

For optimal efficiency and service life, it is recommended that the operating viscosity (at operating temperature) be selected within the following range:

V_{opt} Optimum operating viscosity 16...36 mm²/s
Depends on the circuit temperature (closed circuit).

> Viscosity Limits

Viscosity limits are as follows:

$V_{min} = 5 \text{ mm}^2/\text{s}$

Short-term ($t < 3 \text{ min}$)

Permissible maximum temperature $t_{max} = +115^\circ\text{C}$

$V_{max} = 1600 \text{ mm}^2/\text{s}$

Short-term ($t < 3 \text{ min}$)

During cold start ($p \leq 3 \text{ Mpa}$, $n \leq 1000 \text{ rpm}$, $t_{min} = -40^\circ\text{C}$)

This applies only to no-load starts; the optimum operating viscosity must be reached within 15 minutes.

> Selection Diagram

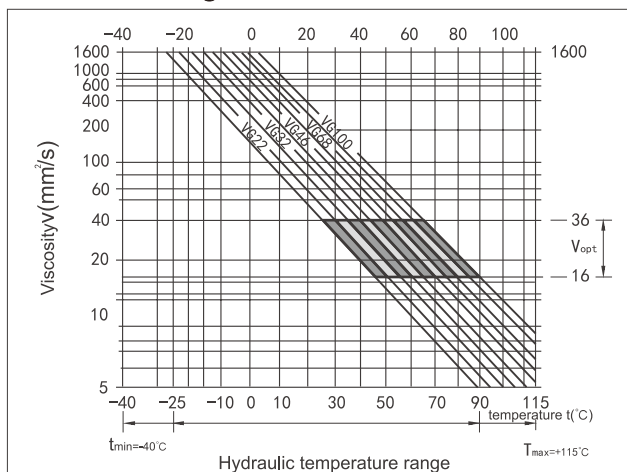

> Hydraulic Fluid Selection Instructions

To select the correct hydraulic fluid, the operating temperature in relation to the ambient temperature must be known. For a closed circuit, this refers to the circuit temperature.

The hydraulic fluid should be selected so that its viscosity, within the operating range (V_{opt}), lies in the optimum zone (see the shaded area of the selection diagram). We recommend choosing a higher viscosity grade under identical conditions.

Example: At an ambient temperature of X °C, the operating temperature in the circuit is 60 °C. Within the optimum operating viscosity range (corresponding to the shaded area), both viscosity grades VG46 and VG68 are suitable. In this case, VG68 should be selected.

Important note: The case drain temperature, influenced by pressure and speed, is always higher than the circuit temperature. The temperature at any point in the system must not exceed 115 °C.

> Filtration

The finer the oil filtration, the higher the oil cleanliness, and the longer the service life of the axial piston components. To ensure proper functioning of the axial piston components, the minimum required oil cleanliness level is:

Class 20/18/15 according to ISO 4406.

Depending on the system and application, we recommend: Filter with $\beta_{20} \geq 100$.

The beta (β) value must not decrease when the filter element's differential pressure increases.

At elevated fluid temperatures (90 °C up to a maximum of 115 °C), the minimum cleanliness level should be: Class 19/17/14 according to ISO 4406.

> Operating Pressure Range

input

Variable displacement pump

Charge pressure ($n = 2000 \text{ rpm}$) P_{sp} _____ 2.3 Mpa

Charge pump

Inlet pressure P_{smin} ($V \leq 30 \text{ mm}^3/\text{s}$) _____ $\geq 0.08 \text{ Mpa}$

> Shaft Seal

Permissible Pressure Load

The service life of the shaft seal is influenced by the pump speed and the case drain pressure. The average sustained case drain pressure at recommended operating temperature must not exceed 0.3 MPa (with a maximum case drain pressure of 0.6 MPa at reduced speeds).

Short-term ($t < 0.1 \text{ s}$) absolute peak pressures up to 1 MPa are permissible. The higher the frequency of pressure peaks, the shorter the service life of the shaft seal.

The pressure inside the casing must be equal to or greater than the external pressure on the shaft seal.

Temperature Range

FKM (fluorocarbon rubber) shaft seals are suitable for a case temperature range of -25 °C to +115 °C.

➤ **Technical Data Sheet (Theoretical Data)**

Scale		Unit	56	
Displacement	Variable displacement pump	V_{gmax}	mL/r	56
	Fixed displacement motor	V_{gmax}	mL/r	56
	Charge pump(P=2.3MPa)	V_{gmax}	mL/r	13.6
Speed	Input speed	n_{max}	rpm	3000
		n_{min}	rpm	800
	Output speed	n_{max}	rpm	3000
		n_{min}	rpm	0
Flow	At $n_{o max}$ continuous and $V_{g max}$		L/min	168
Relief pressure			MPa	39
Weight			KG	32

➤ **Specification Calculation**

Flow $q_v = \frac{V_g \cdot n \cdot \eta_v}{1000}$ [L/min] $V_g =$ Displacement per revolution mL/r

Torque $T = \frac{V_g \cdot \Delta P}{20 \cdot \pi \cdot \eta_{mh}}$ [Nm] $\Delta P =$ Pressure differential bar

Power $P = \frac{2\pi \cdot T \cdot n}{60000} = \frac{q \cdot \Delta P}{600 \cdot \eta_t}$ [KW] $n =$ Speed rpm

$\eta_v =$ Volumetric efficiency

$\eta_{mh} =$ Mechanical-hydraulic efficiency

$\eta_t =$ Total efficiency

➤ **Displacement Control Method - Mechanical servo control, HW**

Depending on the operating direction (a or b) of the control lever, the pump control cylinder receives pilot pressure via the HW control unit. This allows the swash plate, and thus the displacement, to be adjusted steplessly. Each operating direction of the control lever corresponds to a flow direction.

Deflection angle β of the control lever during pivoting:

Control start: $\beta = \pm 2.5^\circ$

Control end: $\beta = \pm 21^\circ$ (at maximum displacement $V_{g \max}$)

Mechanical stop: $\pm 31^\circ$

The pivoting of the HW control lever must be limited by an external position sensor (setpoint device).

Note: When no torque is applied to the lever of the HW control unit, the spring-centering function automatically returns the pump to the neutral position ($V_g=0$), regardless of the lever's deflection angle.

➤ **Relationship between Rotation Direction- Control Input-and Flow Direction**

Input rotation direction	Operating position	High-pressure line
CW	a	B
	b	A
CCW	a	A
	b	B

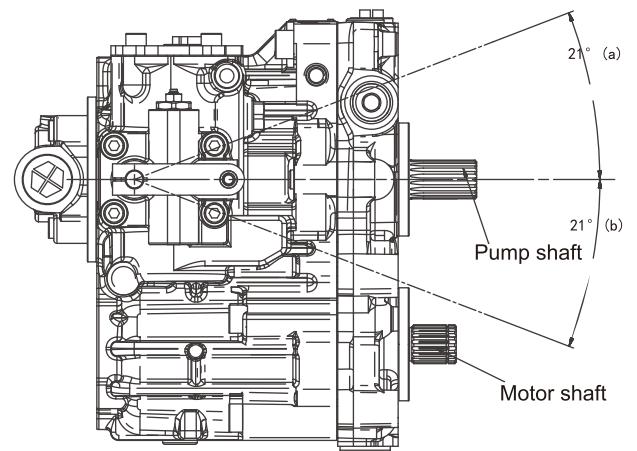
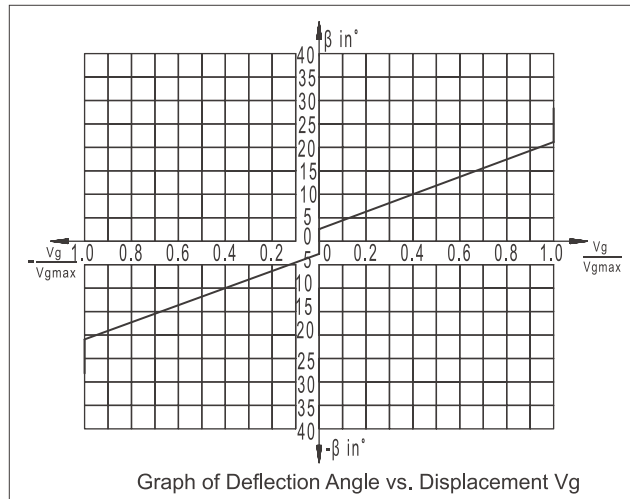

➤ **Hydraulic Schematic Diagram**

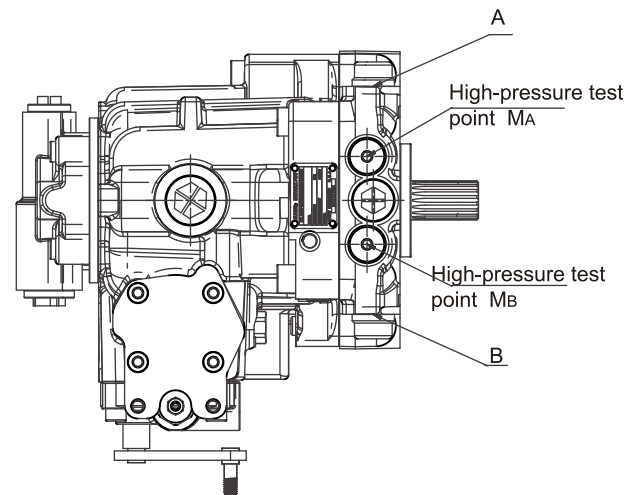
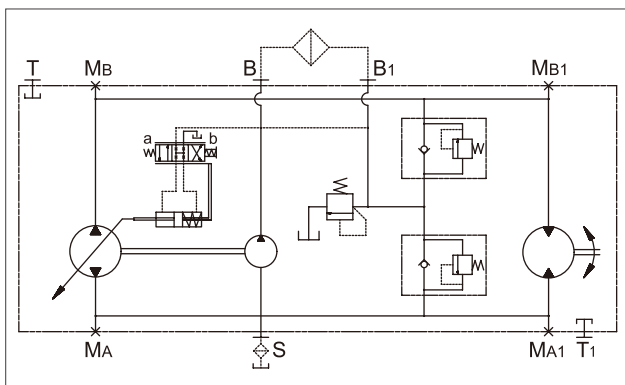

➤ Installation Connection Dimensions

HW1 - Mechanical servo control, without hand lever

HW2 - Mechanical servo control, with cross handle

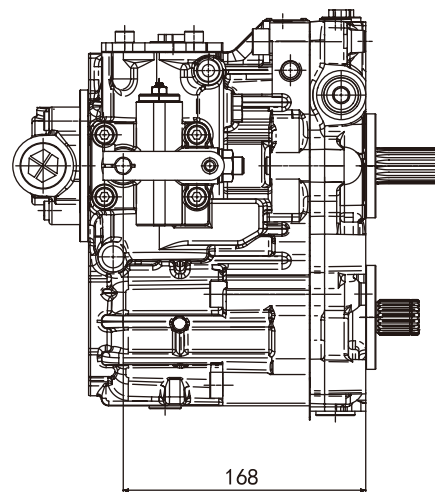
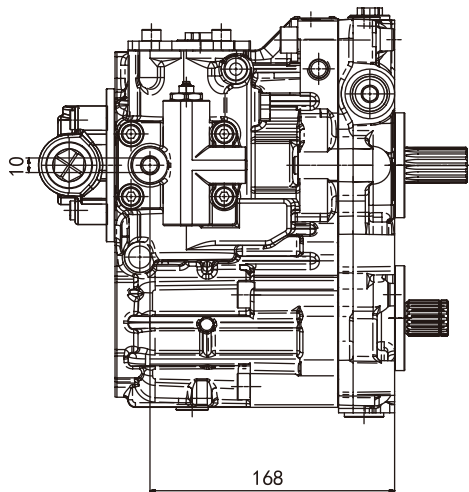
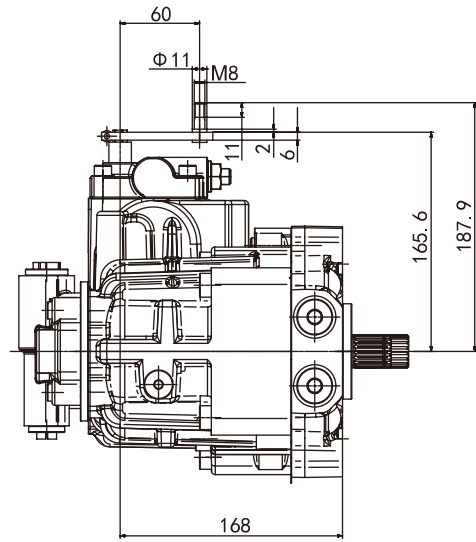
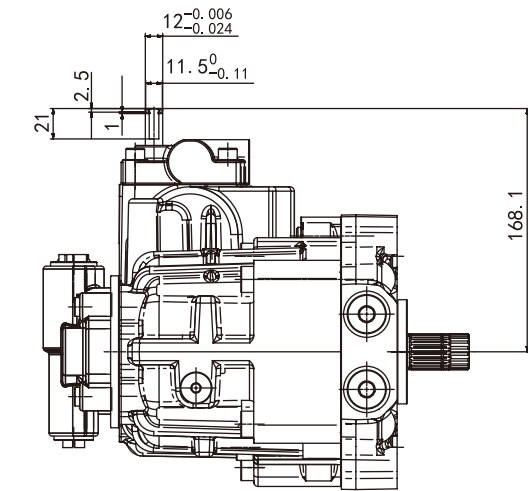

➤ Installation Connection Dimensions

HW3 - Mechanical servo control, with Z-handle

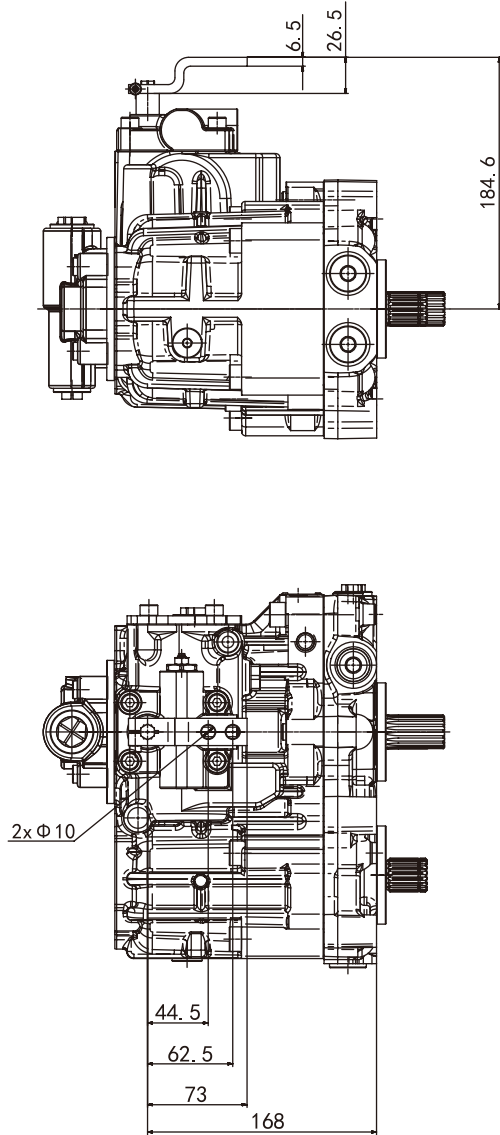

EP1 - Electrical proportional control

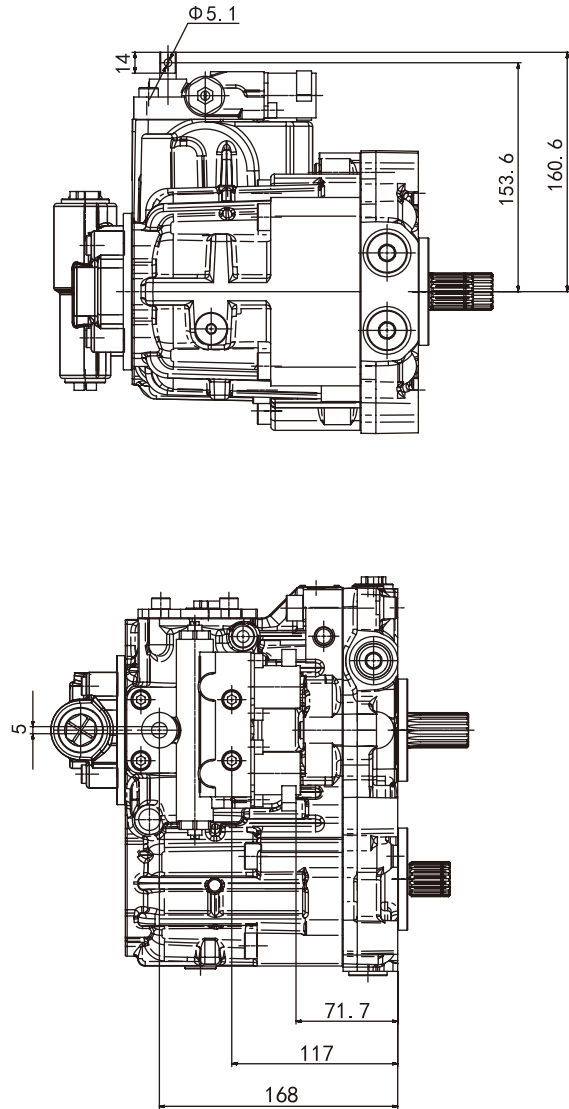

➤ Installation Connection Dimensions

Pump shaft configuration J1

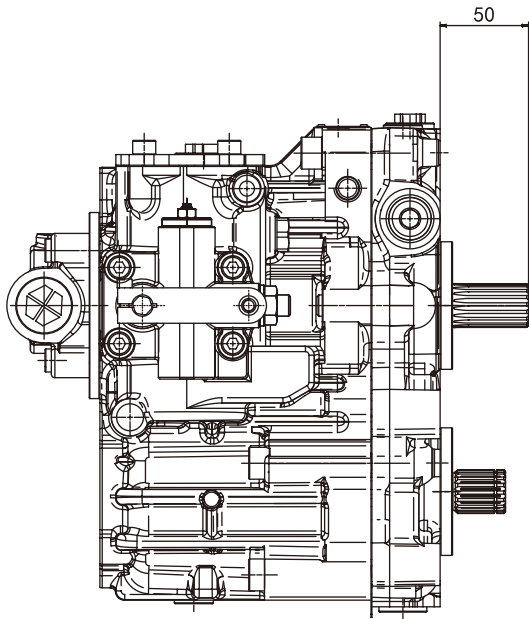

Pump shaft configuration J2

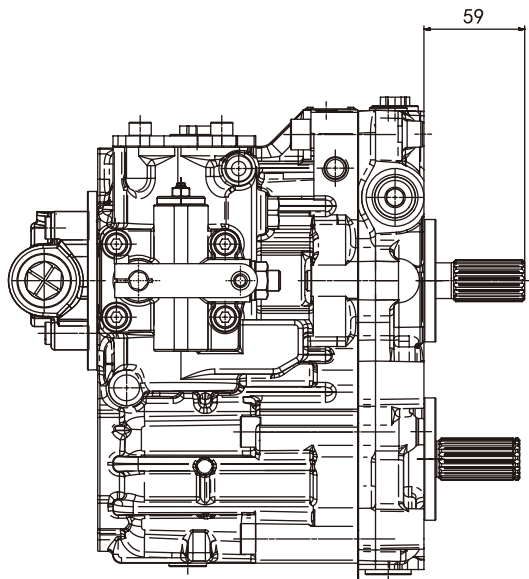

➤ Installation Connection Dimensions

Motor shaft configuration J1

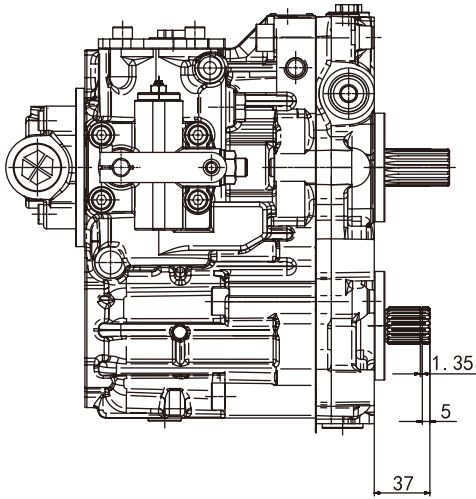

Motor shaft configuration J3

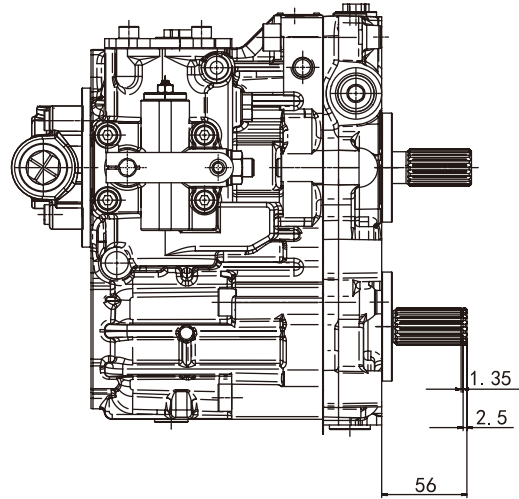

Motor shaft configuration J2

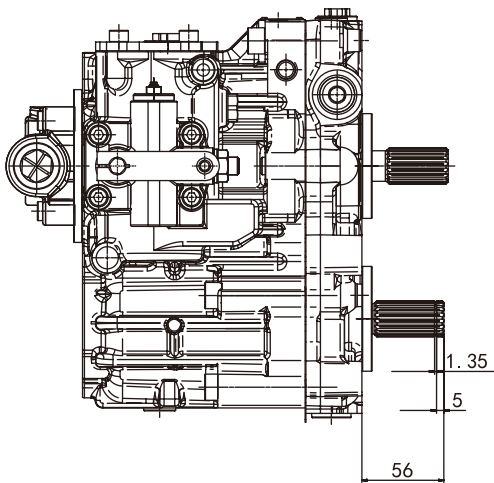

Motor shaft configuration J4

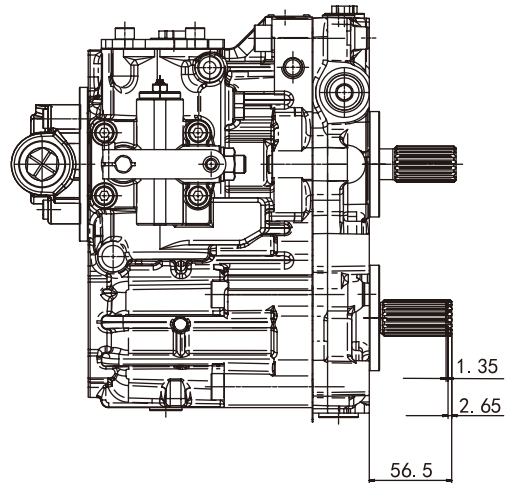

➤ Installation Connection Dimensions

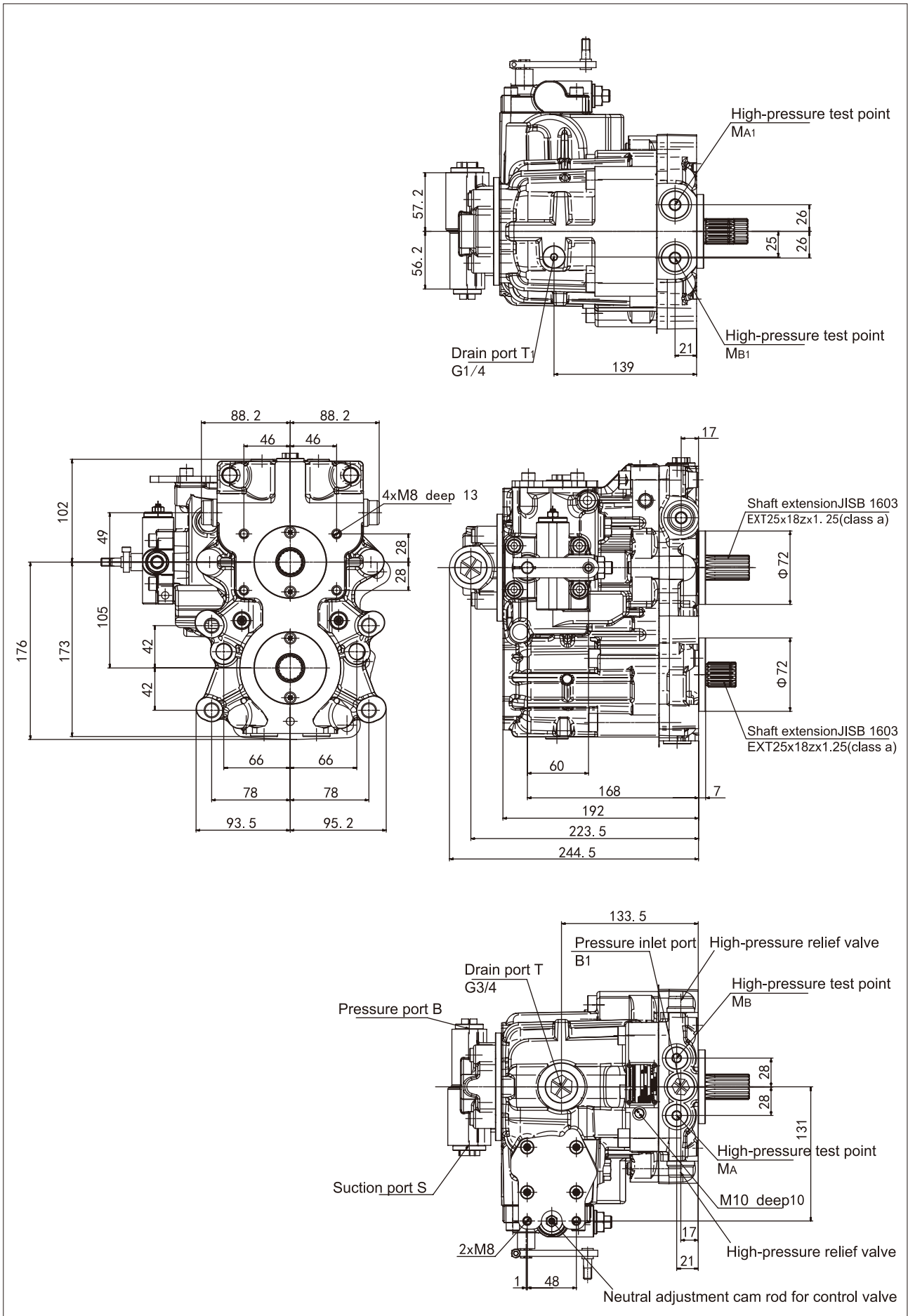

Since 2002 Over twenty years of deep cultivation in the field of hydraulic Solutions

HYTEK is a high technology enterprise integrating R&D, production, sales and service of hydraulic power products. Provides professional hydraulic transmission control products and solutions for construction machinery, road machinery, material handling machinery, agricultural and forestry machinery, industrial equipment and other fields. After more than 20 years of continuous R&D, technological innovation, market development and application services, technical level and the scale of production and sales have been on the forefront of the industry. Hytek has been committed to helping the development of subdivided industries with innovative hydraulic technology, "focusing on the challenges and pressures of customers, providing competitive products and solutions, reducing costs and increasing efficiency for customers, and continuously creating maximum value".

Product series

- Open circuit pump
- Closed Circuit Pump
- Fixed Displacement Motor
- Variable Displacement Motor
- Hydrostatic Transmission Unit
- Internal Gear Pump
- Vane Pump
- Proportional valve/
Industrial Hydraulic Valve

For more information,
please visit our official website and social media: en.hytek.cn



@Hytek Power

HYTEK POWER CO.,LTD.

No.156, West Yuele Street, Lucheng District, Wenzhou City 325029, Zhejiang, CHINA

Email: globalsales@hytek.cn

America Canada Germany Italy Russia Türkiye Australia South Korea Thailand India Indonesia

HYTEK-REV1.0 03/2026

If there are any other modifications, no further notice will be given.