

Axial Piston Variable Pump HP3VO Series 01

Size: 40/45/63/72/85 mL/r
 Rated pressure: 28 MPa
 Max. pressure: 32 MPa



Features



- Axial variable pump of swashplate design for hydrostatic drives in open circuits
- The flow is proportional to the drive speed and displacement and is infinitely varied
- The drive shaft allows axial and radial loading
Various control options to satisfy different operating requirements
- High power to weight ratio
- Excellent suction characteristics
- Diverse control options, short control response time
- Compact structure, small size, low noise

Contents



- Model Code.....02
- Structure.....05
- Technical Data.....07
- DR Pressure Control.....08
- DRG Remotely Pressure Control.....09
- DRF/DRS Pressure Flow Control.....10
- LA... Power Control.....11
- LE Electro Proportional Power Control.....12
- EP Electro Proportional Displacement Control...13
- Installation Dimensions,40/45,NO63.....14
- Installation Dimensions,63/72.....17
- Installation Dimensions,85.....20
- Installation Dimensions-Through Drive.....26
- Installation Instructions.....27

> Model Code

	b	c	A	B		I	J	K	M	N	P	R	S	X	Z
HP3V		O			/	01			-						-

Axial piston unit

—	Swashplate design, variable piston pump	HP3V
---	---	------

Pressure rating

b		40	45	63	72	85	
	Conventional (without code)	●	●	●	●	●	
	Rated pressure: 21 MPa Max. pressure: 25 MPa	○	○	●	○	○	N

Operation

c	Open circuit	O
---	--------------	---

Displacement

A	Geometric displacement, in mL/r	40	45	63	72	85	
---	---------------------------------	----	----	----	----	----	--

Variable control method

B	Pressure control					40	45	63	72	85				
						●	●	●	●	●	DR			
					load sensitive control	X-T open		●	●	●	●	●	DRF	
						X-T plugged	with flushing	●	●	●	●	●	DRS	
					without flushing		○	○	○	○	○	DRSC		
	remote control				●	●	●	●	●	DRG				
	Power control With pressure cut-off				Beginning of control	10-35bar	●	●	●	●	—	LA5D		
						36-70bar	●	●	●	●	—	LA6D		
						71-105bar	●	●	●	●	—	LA7D		
						106-140bar	●	●	●	●	●	LA8D		
						141-230bar	●	●	●	●	●	LA9D		
					remote control		Beginning of control	see LA.D	○	○	●	●	●	LA.DG
					load sensitive X-T plugged	see LA.D		●	●	●	●	●	LA.DS	
						negative control		U=12V	○	○	●	●	○	LE1.DS
	U=24V	○	○	○	○		●	LE2.DS						
Electro proportional displacement control				pressure cut-off	positive control	U=12V	○	○	●	●	○	EP1D		
						U=24V	○	○	○	○	○	EP2D		

> Model Code

	b	c	A	B		I	J	K	M	N	P	R	S	X	Z	
HP3V		O			/	01			-						-	

Series

I	Series 01	01
---	-----------	----

Oil port type

J		40	45	63	72	85	
	UN/UNF,O-ring seal,with standards SAE J1926	●	●	●	●	●	S
Drain Port: BSPP,O-ring seal,with standards JIS B2351-1G Control Por: BSPP,ED seal,with standards ISO 1179-1	●	●	●	●	●	G	
Metric,ED seal,with standards ISO 9974-1	●	●	●	●	○	I	

Direction of rotation (viewed on drive shaft)

K		40	45	63	72	85	
	CW	●	●	●	●	●	R
CCW	●	●	●	●	●	L	

Sealing material

M		40	45	63	72	85	
	NBR seal + FKM shaft seal	○	○	●	●	○	N
NBR seal	○	○	●	●	●	P	
FKM shaft	●	●	●	●	○	V	

Drive shaft

N		40	45	63	72	85	
	7/8" 13T 16/32DP	●	●	● ¹⁾	—	—	S1
1" 15T 16/32DP	●	●	●	●	—	S2	
1 1/4" 14T 12/24DP	—	—	●	●	●	S3	
1 1/2" 17T 12/24DP	—	—	—	—	○	S4	

Mounting flange

P		40	45	63	72	85	
	ISO 3019-2,2 hole	●	●	○	○	○	A
SAE J744,2 hole	●	●	●	●	●	C	
SAE J744,2 hole(second series)	○	○	●	●	○	Z	
SAE J744,4 hole	○	○	○	○	●	D	

Working ports

R			40	45	63	72	85	
	SAE port flange, metric fastening thread	rear	not used for through drive	●	●	● ²⁾	○	○
side		used for through drive	●	●	●	●	●	12
side, 90 ° offset		not used for through drive,for CCW	○	○	○	○	○	13
SAE port flange, UNC fastening thread	side	used for through drive	○	○	○	○	●	62

1):63cc for "HP3VNO"

2):63cc for "HP3VNO"

> Model Code

	b	c	A	B		I	J	K	M	N	P	R	S	X	Z
HP3V		O			/	01			-						-

Through drive

	Flange SAE J744			Splined shaft			40	45	63	72	85	
	S	Without through drive						●	●	●	●	●
82-2(A)		5/8"	9T	16/32DP			●	●	●	●	●	K01
		3/4"	11T	16/32DP			●	●	●	●	●	K52
101-2(B)		7/8"	13T	16/32DP			●	●	●	●	●	K68
		1"	15T	16/32DP			●	●	●	●	●	K04
127-4(C)		1 1/4"	14T	12/24DP			○	○	○	○	●	K15
		1 1/2"	17T	12/24DP			○	○	○	○	○	K16
127-2(C)		1 1/4"	14T	12/24DP			○	○	○	○	●	K07
		1 1/2"	17T	12/24DP			○	○	○	○	○	K24

Solenoid connector

	40	45	63	72	85							
X	Without connector (without solenoid, only for hydraulic control(without code))						●	●	●	●	●	
	DEUTSCH DT04-2P, 2-pin plastic connector, without diode suppressor (electric control)						○	○	●	●	○	P
	AMP 17454-2, 2-pin plastic connector						○	○	●	●	○	A

Special configuration

	40	45	63	72	85							
Z	Without special configuration (without code)						●	●	●	●	●	
	Special configuration						○	○	○	○	○	***

● Available ○ On request — Not available ■ Recommended model

> Structure

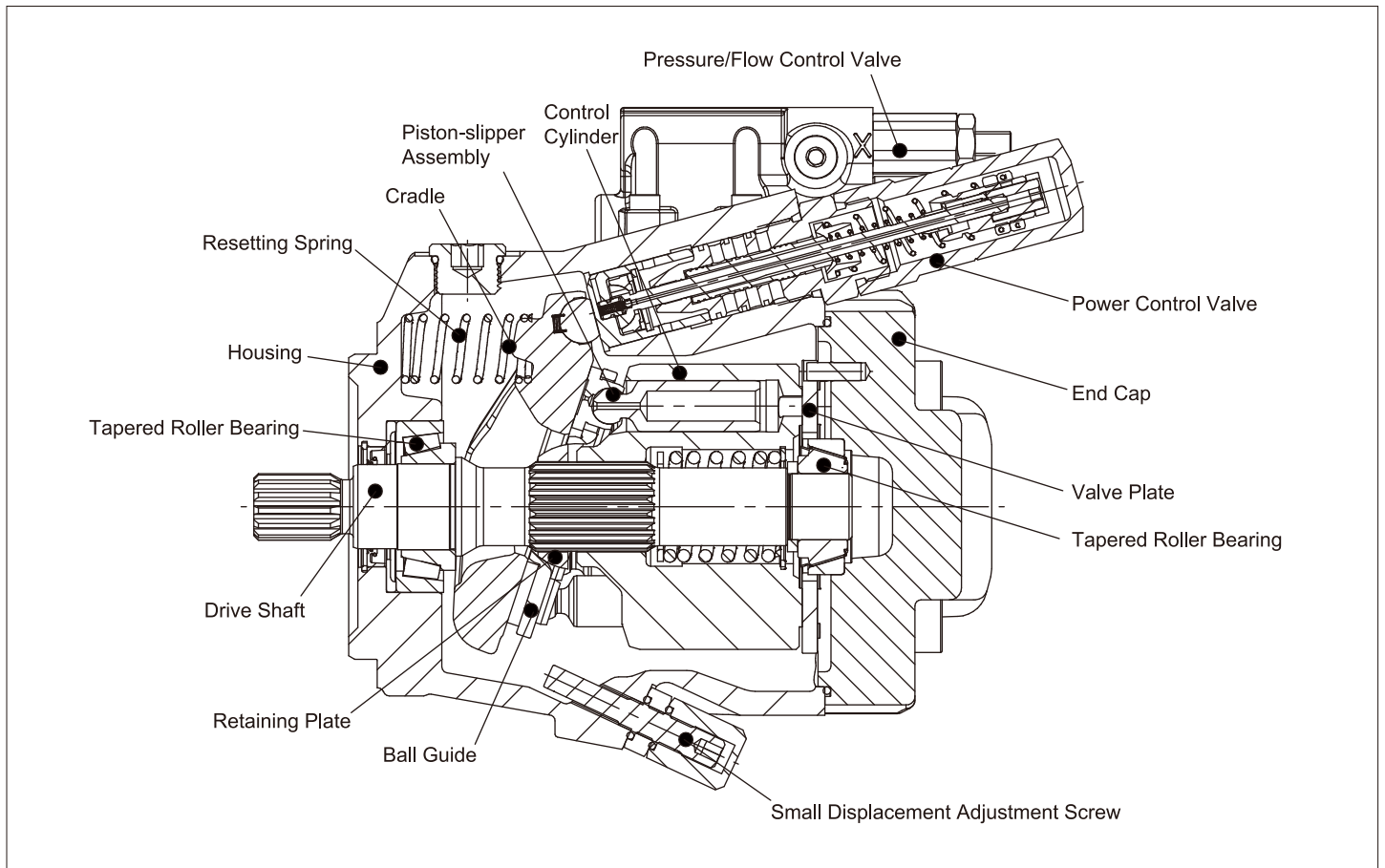

> Hydraulic Fluid

Mineral oil

> Working Viscosity

In order for the optimum efficiency and service life, it is recommended to select the working viscosity at working temperature within the range below:

V_{opt} = optimal working viscosity 16...36 mm²/s

It is subject to the reservoir temperature of an open circuit.

> Limit Viscosity

Limit viscosity:

V_{min} = 10 mm²/s

Short-term operation, at permissible maximum leakage temperature of 90 °C

V_{max} = 1000 mm²/s

Short-term operation, cold start

> Temperature Range

t_{min} = -25 °C

t_{max} = 90 °C

> Selection Diagram

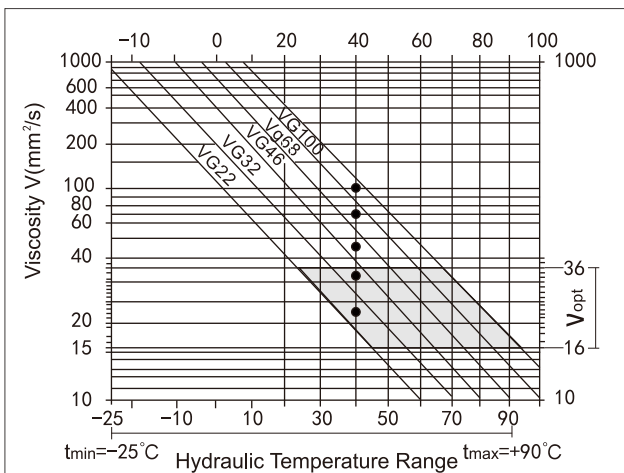

> Instructions on Selection of Hydraulic Fluid

The working temperature dependent on the ambient temperature is required for correct selection of hydraulic fluid. It refers to the circuit temperature of a closed circuit and the reservoir temperature of an open circuit.

The hydraulic fluid should be so selected that the working viscosity in the working range is within the optimum range (V_{opt} , the shaded area on the selection diagram). The higher viscosity is recommended under the same conditions.

For example:

At an ambient temperature of X °C, the working temperature of the circuit is 60 °C. The viscosity within the optimum range (V_{opt} , shaded area) is VG46 or VG68 and the latter should be selected.

Note:

The case drain temperature depends on the pressure and speed, and it is always higher than the circuit temperature. The temperature at any point within the system should not exceed +115 °C. Please contact us if the above condition cannot be maintained due to extreme working conditions.

> Filtration

Finer filtration improves the cleanliness level of the hydraulic fluid, thus increasing the service life of the axial piston unit. To ensure normal operation of the axial piston unit, a cleanliness level of at least 20/18/15 according to ISO 4406 is to be maintained.

When the hydraulic fluid has a high temperature (+90 °C to +115 °C), the cleanliness level should at least reach 19/17/14 according to ISO 4406. Please contact us if the above cleanliness level cannot be maintained.

> Working Pressure Range

Input

Absolute pressure at port S

$p_{abs min}$ _____ 0.8bar

$p_{abs max}$ _____ 5bar

Output

Absolute pressure at port B

p_{nom} _____ 280bar

p_{max} _____ 320bar

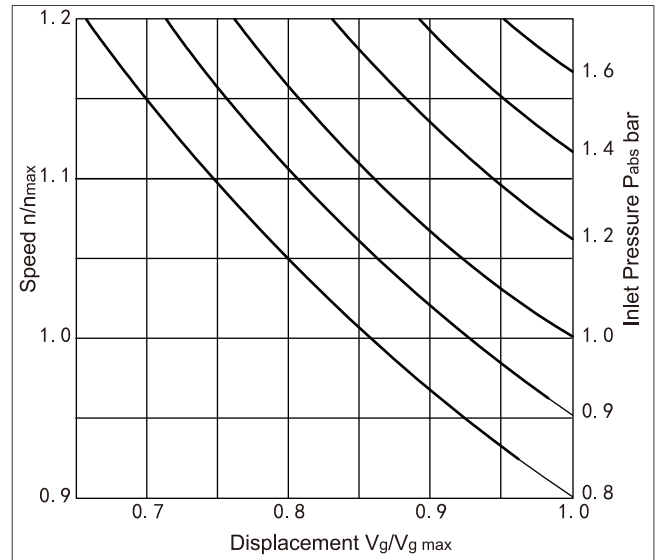

> Case Drain Pressure

Maximum permissible pressure at drain port (L1、L2、L3)

Maximum 0.5 bar higher than inlet pressure at port S

No higher than 2 bar absolute pressure

> Flow Direction

From port S to B

➤ **Technical Data**

Size				40	45	63	72	85
Displacement	Variable pump	$V_{g \max}$	mL/r	40	45	63	72	85
Pressure	Rated pressure	P_{nom}	MPa	28	28	28	28	28
	Maximum pressure	P_{max}	MPa	32	32	32	32	32
Speed ¹⁾	$V_{g \max}$	n_{nom}	rpm	2600	2600	2600	2600	2500
	$V_g < V_{g \max}$	n_{max}	rpm	3120	3120	3140	3140	3000
Flow	n_{nom} and $V_{g \max}$	q_v	L/min	104	117	163.8	187.2	212.5
Power	n_{nom} and $V_{g \max}$, $\Delta p=28MPa$	n_{min}	KW	48.5	54.6	76.4	87.4	99.2
Torque	$V_{g \max}$, $\Delta p=28MPa$	T_{max}	Nm	178	201	281	321	379
Case volume			L	0.5	0.5	0.8	0.8	1
Weight			KG	18	18	22	22	36
Hydraulic oil temperature range			°C	-25°C-110°C				
Hydraulic oil viscosity range			mm ² /s	16-36mm ² /S				

1) The above data is valid only when the inlet pressure at port S is 0.1 MPa absolute pressure.

➤ **Specification Calculation**

Flow	$q_v = \frac{V_g \cdot n \cdot \eta_v}{1000}$	[L/min]	V_g = Displacement, mL/r
			Δp = Differential pressure, MPa
Torque	$T = \frac{V_g \cdot \Delta p}{2 \cdot \pi \cdot \eta_{mh}}$	[Nm]	n = Speed, rpm
			η_v = Volumetric efficiency
Power	$P = \frac{2 \pi \cdot T \cdot n}{60000} = \frac{q_v \cdot \Delta p}{60 \cdot \eta_t}$	[KW]	η_{mh} = Mechanical-hydraulic efficiency
			η_t = Total efficiency

> DR-Pressure Control

The pressure controller can maintain constant pressure of the hydraulic system within its control range despite changes in the flow. The variable pump only supplies as much hydraulic fluid as required by the actuator. If the working pressure exceeds the set point of the integrated pressure control valve, the pump will automatically swivel back until the pressure deviation is corrected.

Start position of depressurized state: $V_{g \max}$

Setting range from 35-320bar(standard:280bar).

Characteristic Curve

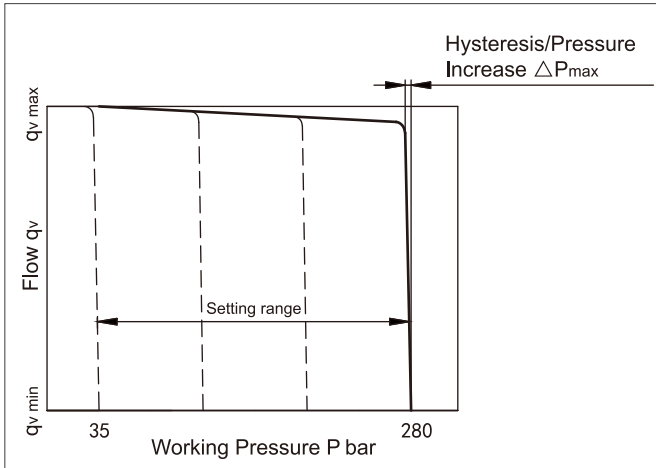

Characteristic curve valid for $n_1=1500\text{rpm}$ and $t_{\text{fluid}}=50^\circ\text{C}$

Circuit diagram

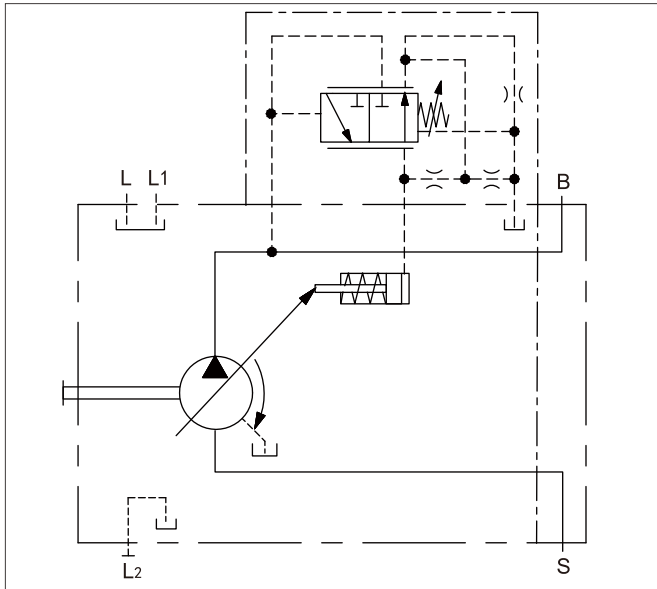

➤ DRG-Remotely Pressure Control

For the remote controlled pressure controller, the pressure limitation is performed using a separately arranged pressure relief valve. any pressure control valve under the pressure set on the pressure controller can be regulated.

A pressure relief valve is externally piped up to port X for remote control. This relief valve is not included in the scope of delivery of the DRG control. A differential pressure of 20bar Δp (standard setting) results in a control fluid quantity of approx. 1.5 l/min at port X.

If another setting is required (range from 14-22bar) please state in plain text.

Directly operated, hydraulically or electrically proportional, suitable for the control fluid quantity mentioned above. The maximum line length should not exceed 2m.

Basic position in depressurized state: $V_{g \max}$

Setting range for pressure control 35-320bar (standard: 280bar).

Setting range for differential pressure 14-22bar (standard: 20bar).

Characteristic Curve

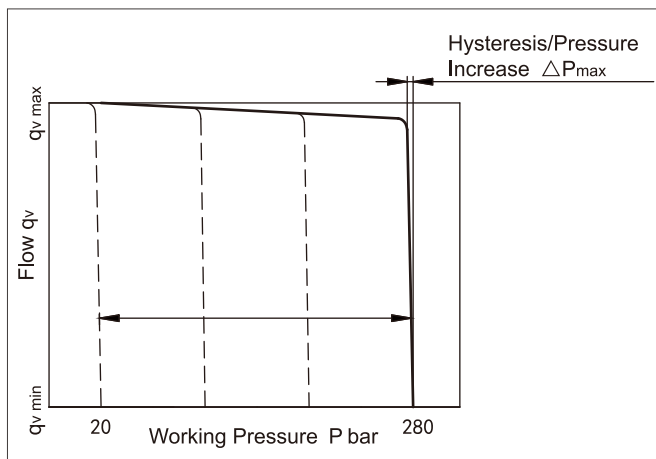

Characteristic curve valid for $n_1=1500\text{rpm}$ and $t_{\text{fluid}}=50^\circ\text{C}$

Circuit diagram

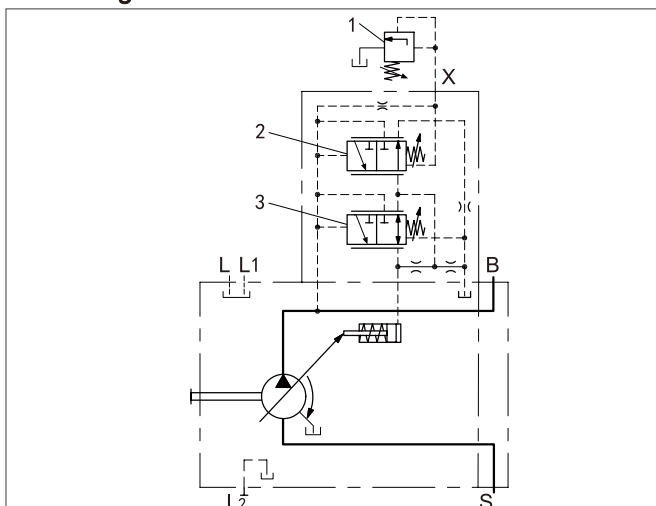

1. The separate pressure relief valve and the line are not included in the scope of delivery.

2. Remote controlled pressure cut-off (G)

3. Pressure controller (DR)

In order to prevent damage to the pump and the system, the permissible setting range must not be exceeded. The range of possible settings at the valve is higher.

DRF/DRS-Pressure Flow Control

In addition to the pressure controller function, an adjustable orifice is used to adjust the differential pressure upstream and downstream of the orifice. This is used to control the pump flow. The pump flow is equal to the actual hydraulic fluid quantity required by the consumer. With all controller combinations, the V_g reduction has priority.

Basic position in depressurized state: $V_{g \max}$

Setting range for pressure control 35-320bar(standard:280bar).

Characteristic Curve

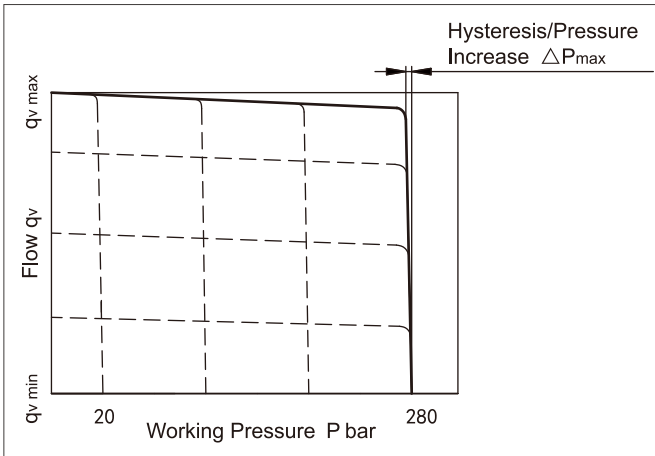

Characteristic curve at variable rotational speed

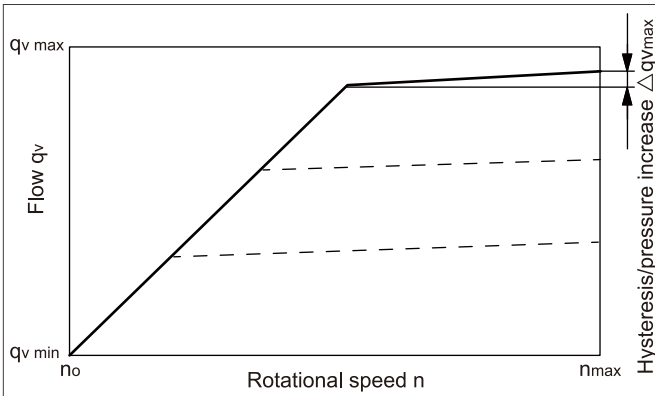

Characteristic curve valid for $n_1=1500\text{rpm}$ and $t_{\text{fluid}}=50^\circ\text{C}$

Circuit diagram

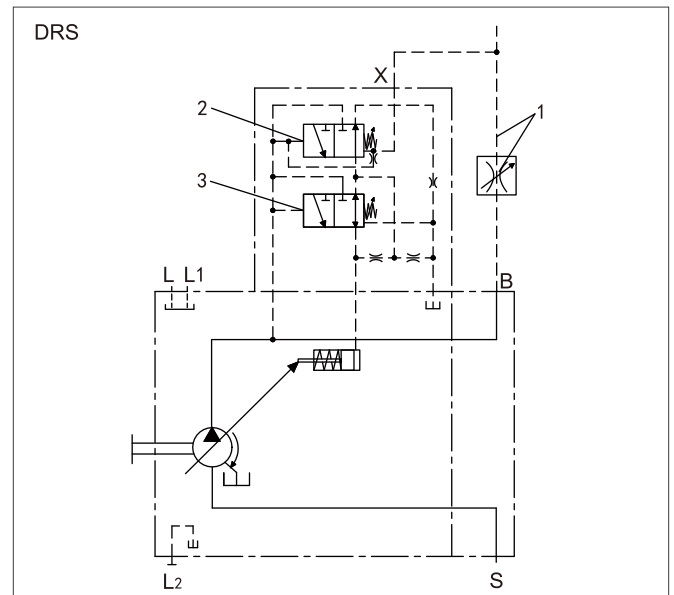
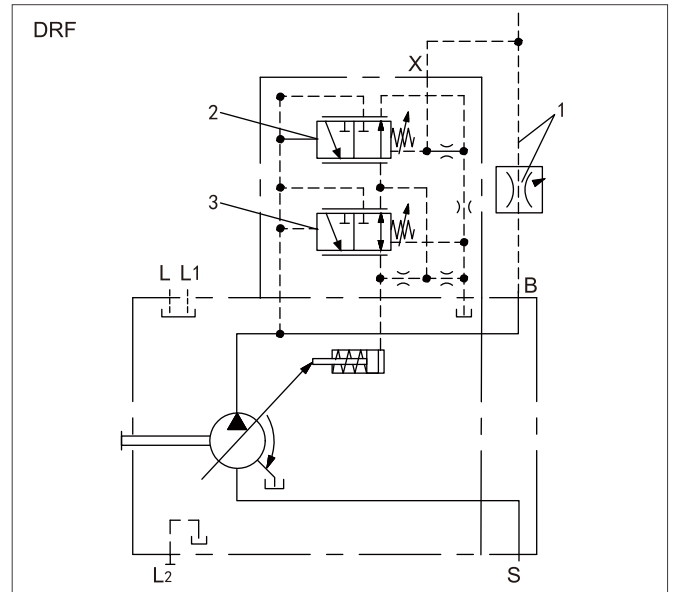

- 1.The metering orifice (control block) and the line is not included in the scope of delivery.
- 2.Flow controller(FR).
- 3.Pressure controller(DR).

In order to prevent damage to the pump and the system,the permissible setting range must not be exceeded.The range of possible settings at the valve is higher.

Notice

The DRS version has no unloading between X and the reservoir. The LS must therefore be unloaded in the system. Because of the flushing function of the flow controller in the DRS control valve, sufficient unloading of the X line must also be ensured.

Differential pressure Δp

Standard setting: 14bar, If another setting is required, please state in the plain text.

Setting range: 14-22bar

Unloading port X to the reservoir results in a zero stroke pressure which is approx.1-2bar higher than the defined differential pressure Δp , in which system influences are not taken into account.

LA...-Power Control

In order to achieve a constant drive torque with varying working pressures, the swivel angle and also the output flow from the axial piston pump is varied so that the product of flow and pressure remains constant.

Flow control is possible below the power control curve.

When ordering please state the power characteristics.

	Torque (Nm)					
Beginning of control	40	45	63	72	85	Type code
10–35bar	10–30	10–30	15–43	17–49.2	–	LA5
36–70bar	30.1–59	30.1–59	43.1–83	49.3–94.9	–	LA6
71–105bar	59.1–84	59.1–84	83.1–119	95–136	–	LA7
106–140bar	84.1–112	84.1–112	119.1–157	136.1–179.4	160.1–212	LA8
141–230bar	112.1–189	112.1–189	157.1–264	179.5–301.7	212.1–357	LA9

Characteristic Curve

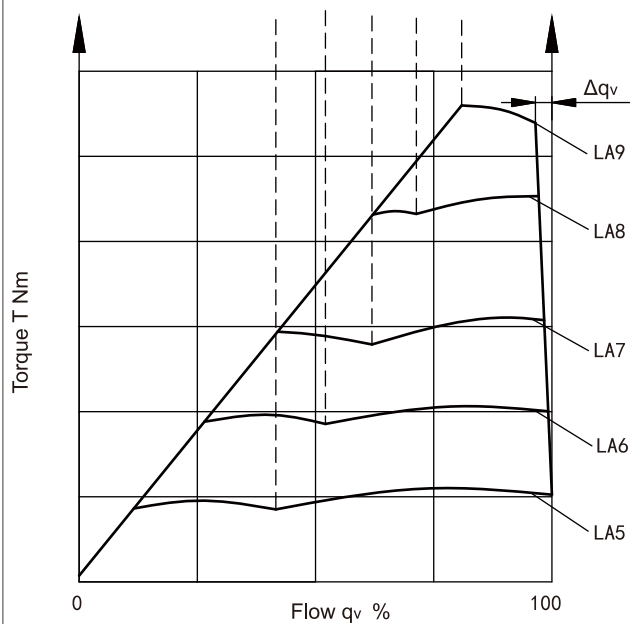
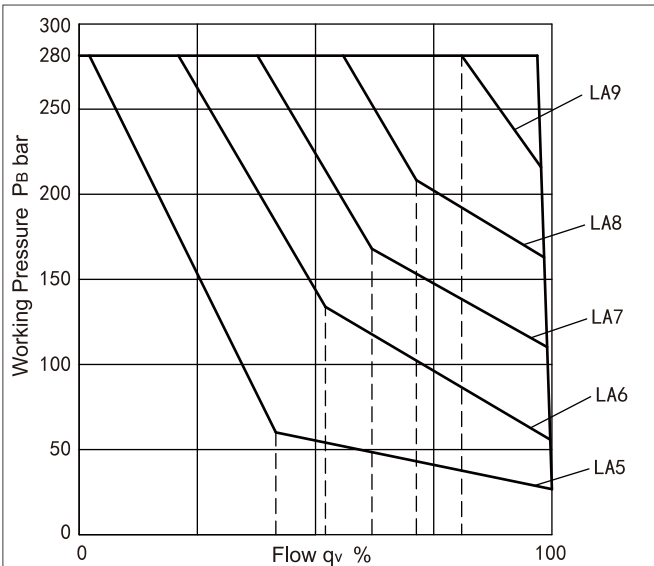

Circuit diagram

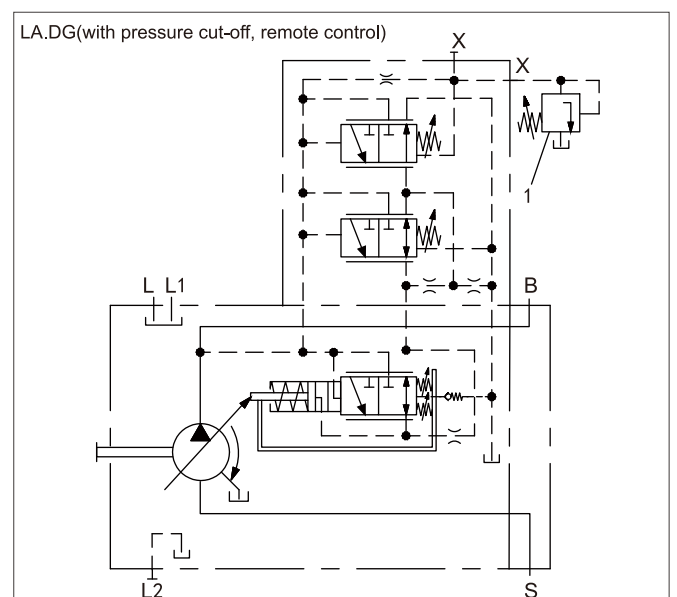
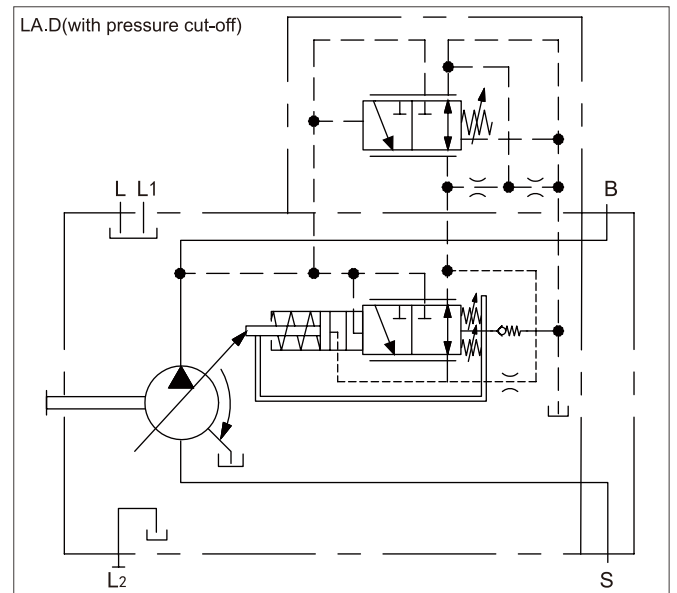
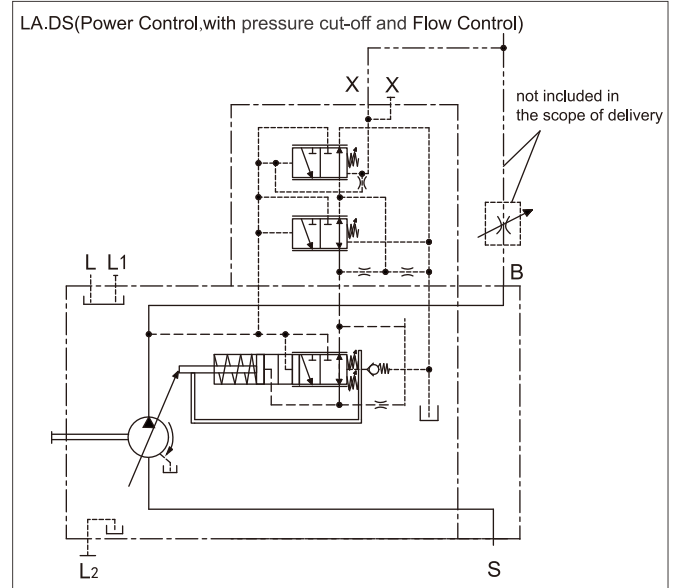

"1" The pressure relief valve is not included in the scope of delivery.

➤ **LE-Electro Proportional Power Control**

Setting range for load sensitivity : 14-22bar(standard:14bar)

Setting range for pressure control : 35-320bar(standard:280bar)

Setting range for Pr port pressure : Connect the oil outlet, enter the pressure reducing valve for secondary pressure reduction.

Technical data, solenoids

Voltage(V)	Current limit(A)	Nominal resistance(Ω)	Insulation level
12	0.85	7.3 \pm 10%(20°C)	H(180°C)
24	0.75	21.2 \pm 10%	UP to IPK6/IPX9K

Circuit diagram

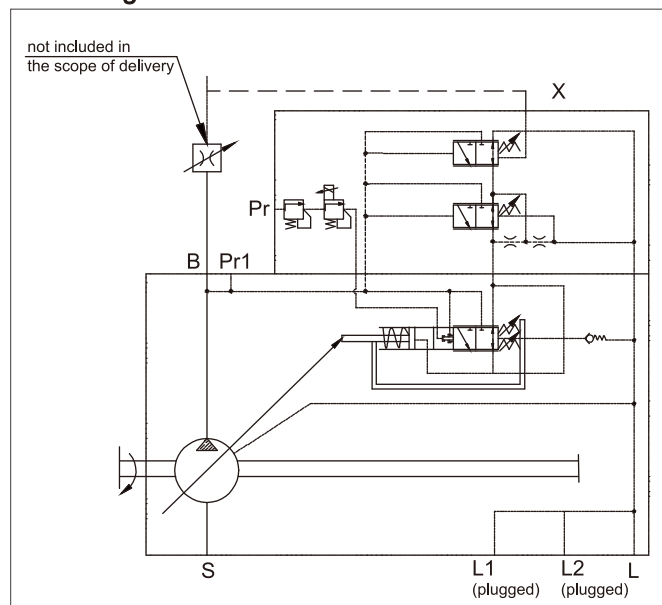

EP-Electro Proportional Displacement Control

Electro proportional control makes a continuous and reproducible setting of the pump displacement possible directly via the cradle.
 The control force of the control piston is applied by a proportional solenoid. The control is proportional to the current .
 In a depressurized state, the pump is swiveled to its initial position ($V_{g \max}$) by an adjusting spring.
 If the working pressure exceeds a limit value of approx.14bar, the pump starts to swivel from $V_{g \max}$ to $V_{g \min}$ without control by the solenoid (control current < start of control).
 With a minimum swivel angle $V_{g \min}$ and de-energized EP solenoids, a minimum pressure of 10bar must be maintained.
 A PWM signal is used to control the solenoid.
 EP.D: The pressure control regulates the pump displacement back to $V_{g \min}$ after the pressure command value has been reached.
 A minimum working pressure of 14bar is needed for safe and reproducible control. The required control fluid is taken from the high pressure.

Characteristic Curve

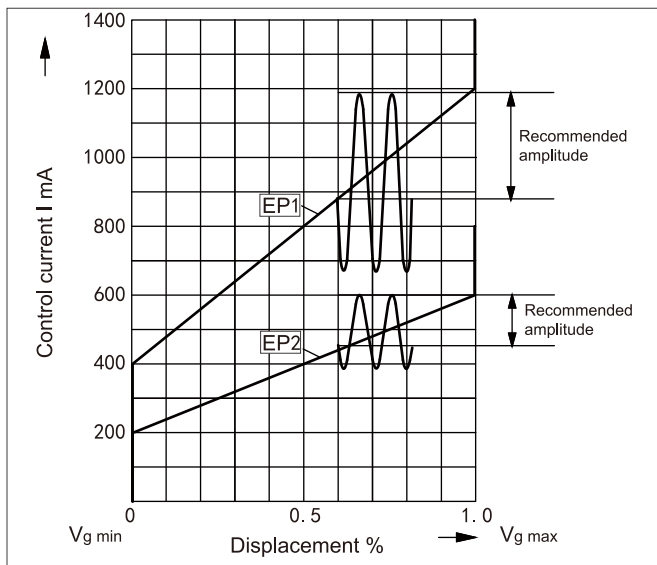

Circuit diagram

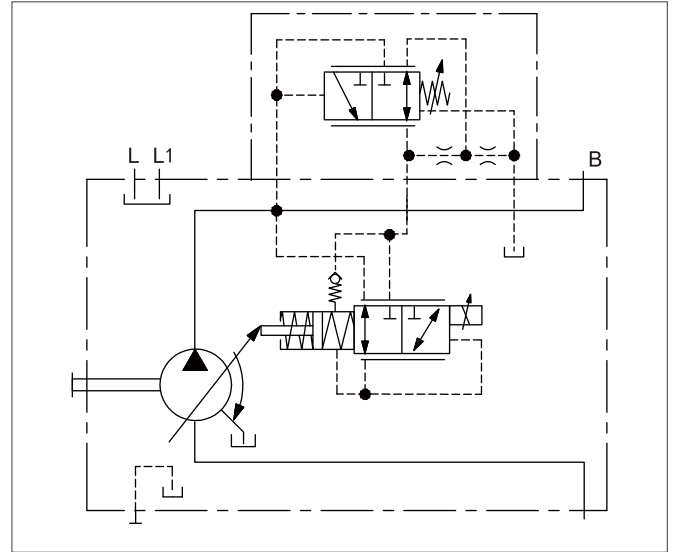

Technical Data-Solenoid	EP1	EP2
Voltage	12V ($\pm 20\%$)	24V ($\pm 20\%$)
Control current Start	400mA	200mA
Control current End	1200mA	600mA
The minimum working stroke to control current flutter is within the control range	352mA	176mA
Dither frequency	100-200Hz	100-200Hz
Current limit	1.54A	0.77A
Nominal resistance (20°C)	5.5 Ω	22.7 Ω
Duty cycle	100%	100%
Control valve operating temperature range	-20°C ~ 115°C	

► Installation Dimensions, 40/45, NO63

DRF/DRS-Pressure, Flow controller, clockwise rotation, mounting flange C

SAE flange working oil port 12

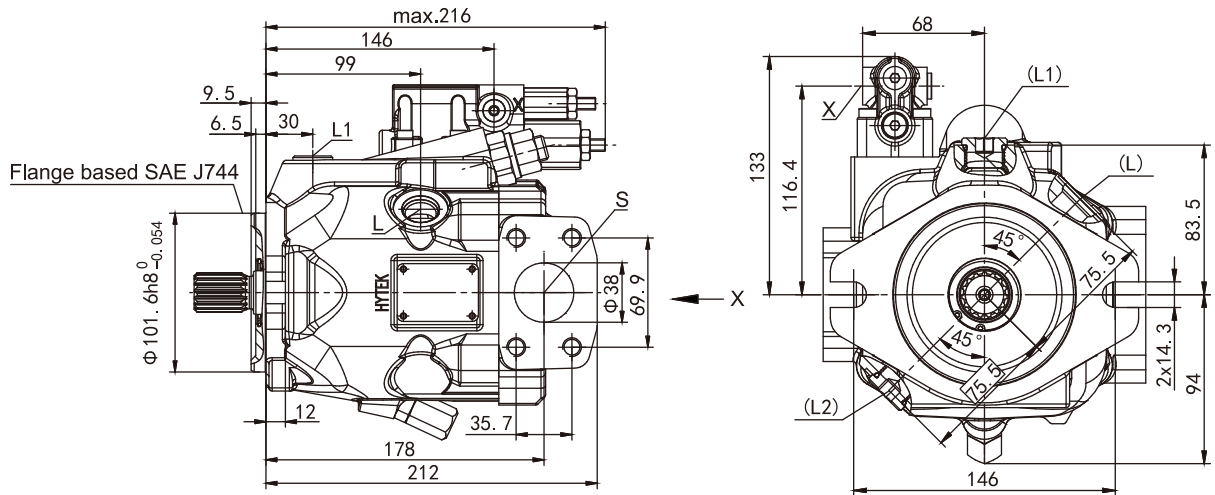

View X

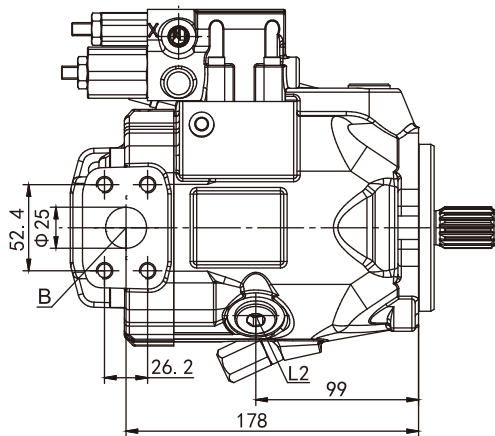

SAE flange working oil port 11

View Y

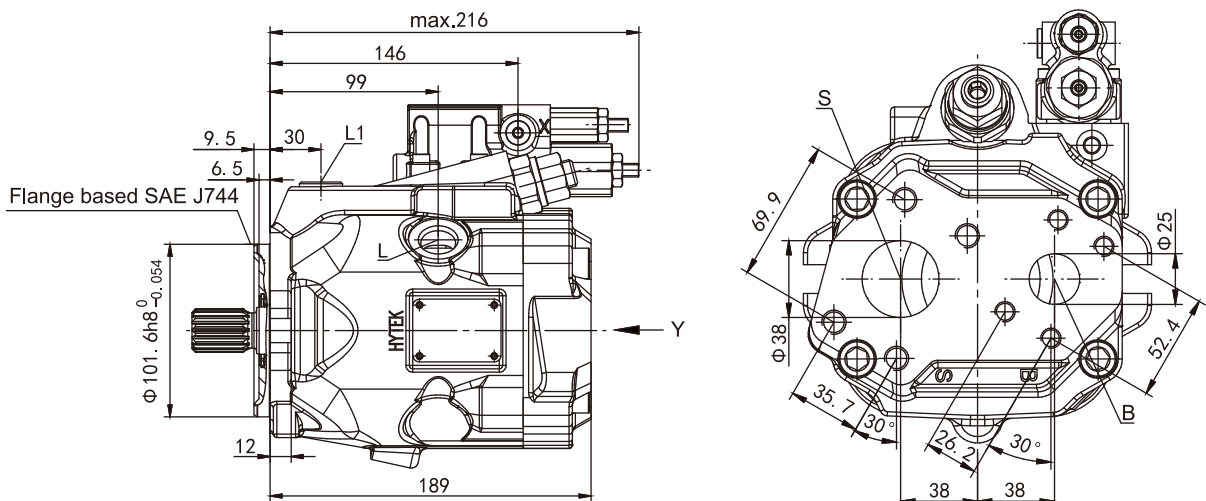

➤ Installation Dimensions, 40/45, NO63

LA.DS-Pressure, Flow, Power controller, clockwise rotation, mounting flange A

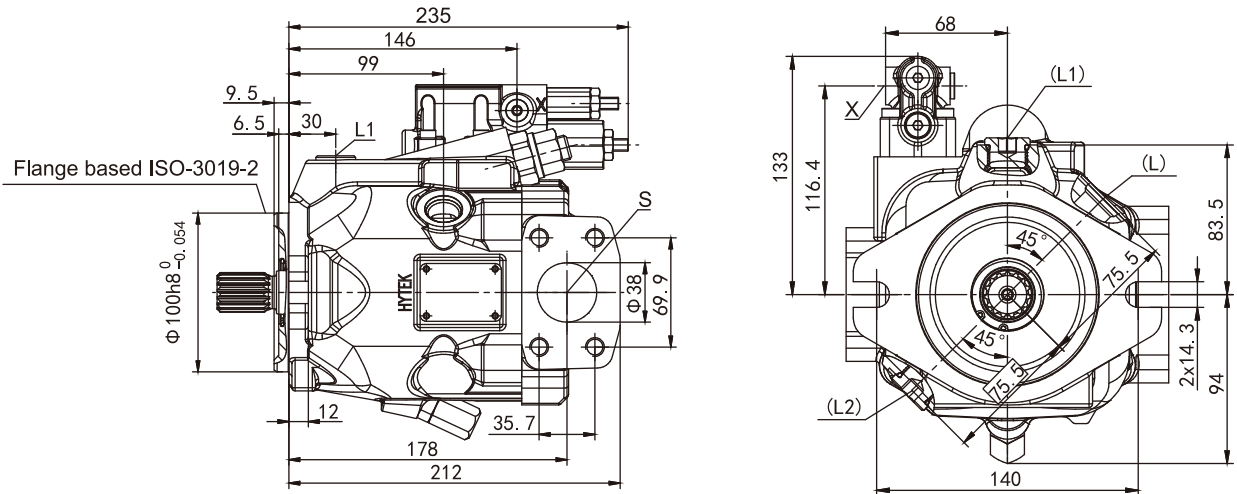

LA.DS-Pressure, Flow, Power controller, clockwise rotation, mounting flange C

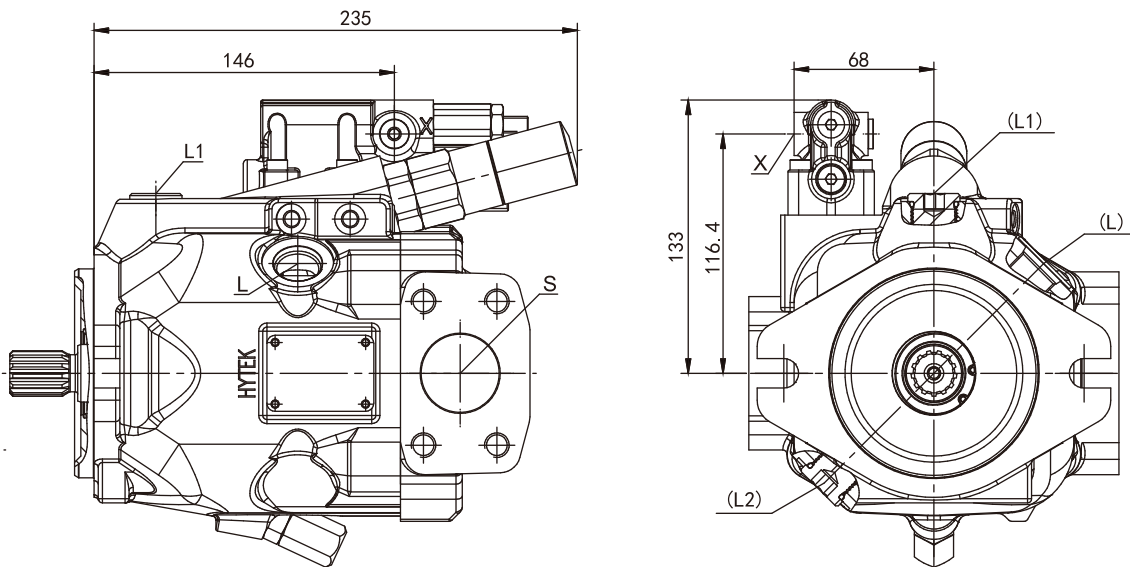

➤ Installation Dimensions, 40/45, NO63

Drive shaft

Splined shaft
Maximum allowable
input torque 198Nm
7/8" SAE J744
S1-13T 16/32DP

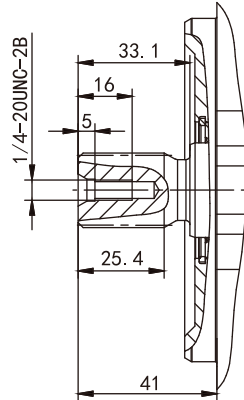

Splined shaft
Maximum allowable
input torque 319Nm
1" SAE J744
S2-15T 16/32DP

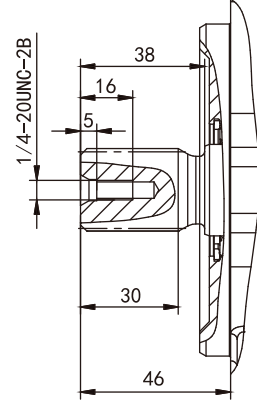

Port type

Port		Standard	Size	Code
L/L1/L2	Drain port	SAE J1926-1	7/8-14UNF-2B,17deep,O-ring seal	S
X	Pilot pressure	SAE J1926-1	7/16-20UNF-2B,11.5deep,O-ring seal	
L/L1/L2	Drain port	JIS B2351-1G	G1/2,20.5deep,O-ring seal	G
X	Pilot pressure	ISO 1179-1	G1/4,12deep,ED seal	
L/L1/L2	Drain port	ISO 9974-1	M22×1.5,17deep,EDseal	I
X	Pilot pressure(M)	ISO 9974-1	M14×1.5,12deep,EDseal	

Working port

Port		Standard	Size	Code
B	Working port	SAE J518C	Φ25	12
	Fastening thread		M10,19deep	
S	Suction port		Φ38	
	Fastening thread		M12,22deep	

➤ Installation Dimensions, 63/72

DRF/DRS-Pressure, Flow controller, clockwise rotation, mounting flange C

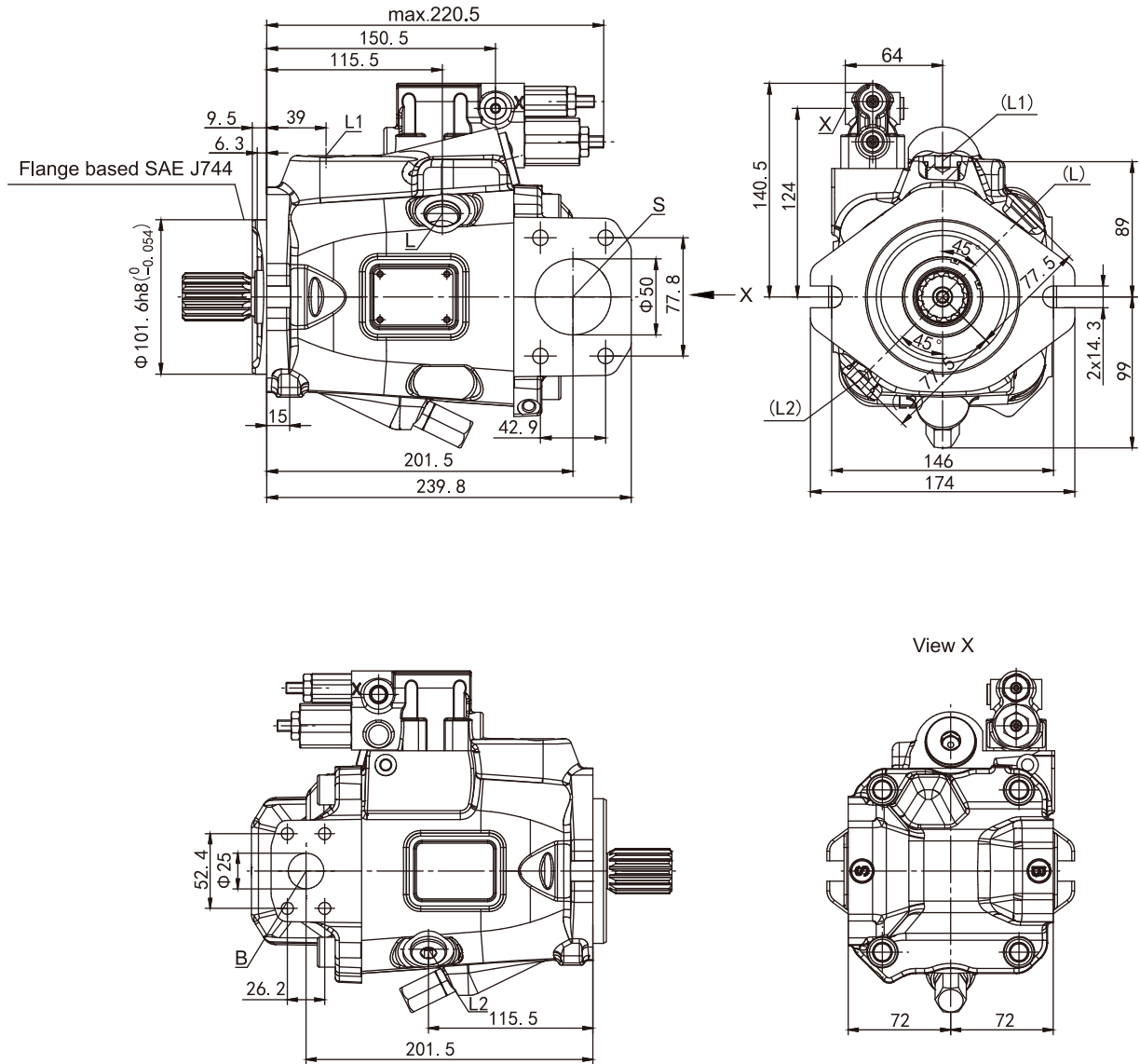

➤ Installation Dimensions, 63/72

LA.DS-Pressure, Flow, Power controller, mounting flange C

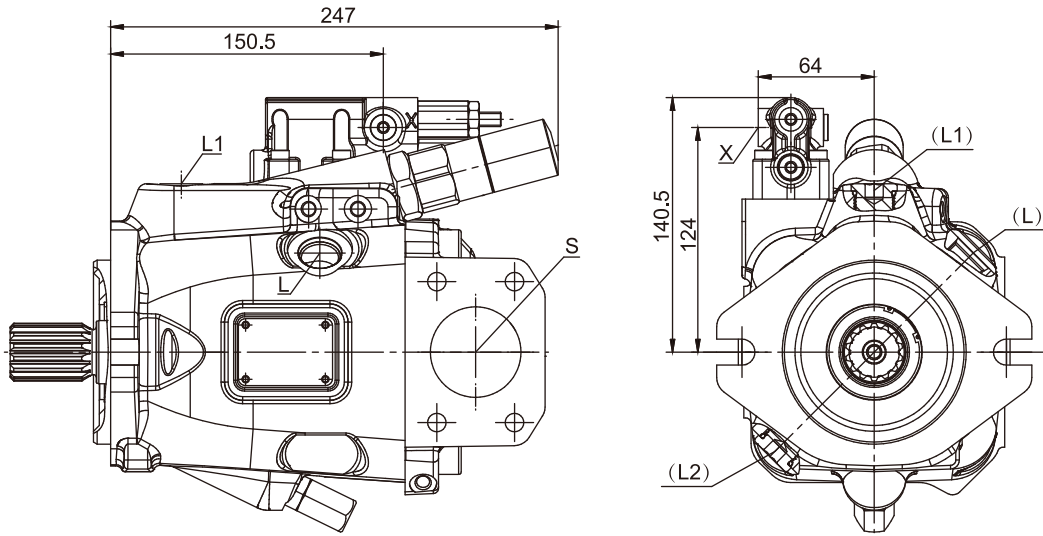

LE.DS-Electrically Proportional Power Control, clockwise rotation, mounting flange Z

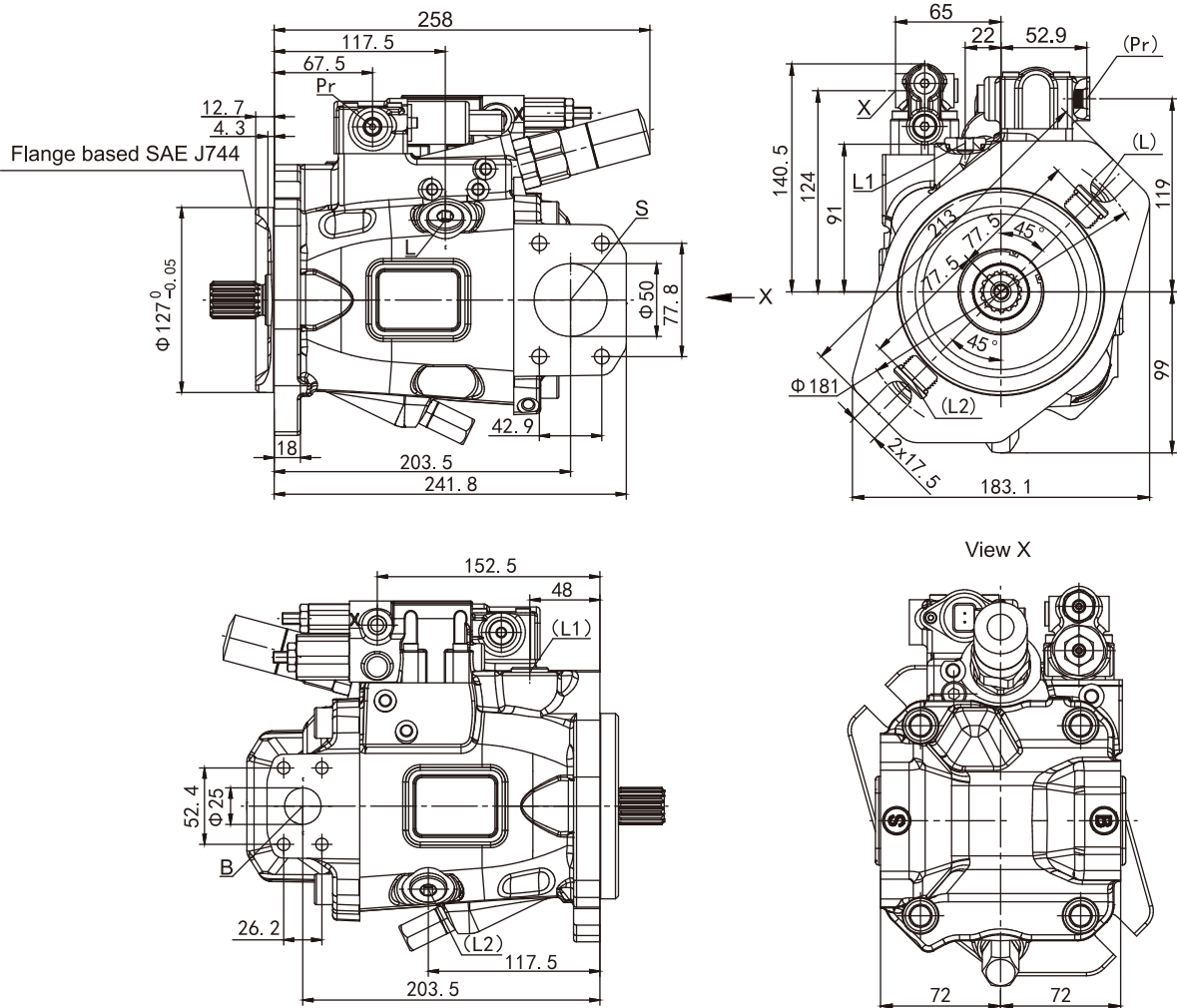

➤ Installation Dimensions, 63/72

Drive shaft

Splined shaft
Maximum allowable
input torque 319Nm
1" SAE J744
S2-15T 16/32DP

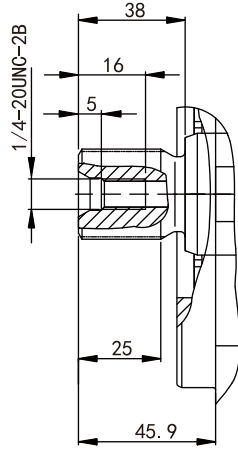

Splined shaft
Maximum allowable
input torque 630Nm
1 1/4" SAE J744
S3-14T 12/24DP

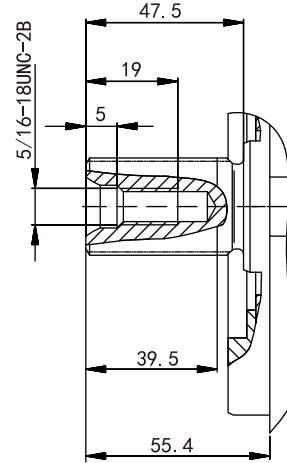

Port type

	Port	Standard	Size	Code
L/L1/L2	Drain port	SAE J1926-1	7/8-14UNF-2B,13deep,O-ring seal	S
X	Pilot pressure	SAE J1926-1	7/16-20UNF-2B,11.5deep,O-ring seal	
L/L1/L2	Drain port	JIS B2351-1G	G1/2,20.5deep,O-ring seal	G
X	Pilot pressure	ISO 1179-1	G1/4,12deep,ED seal	
L/L1/L2	Drain port	ISO 9974-1	M22×1.5,17deep,EDseal	I
X	Pilot pressure(M)	ISO 9974-1	M14×1.5,12deep,EDseal	

Working port

Port	Standard	Size	Code
B	SAE J518C	Working port	Φ25
		Fastening thread	M10,18deep
S	SAE J518C	Suction port	Φ50
		Fastening thread	M12,22deep

► Installation Dimensions, 85

DR-Hydraulic controller, clockwise rotation, mounting flange C, series 01

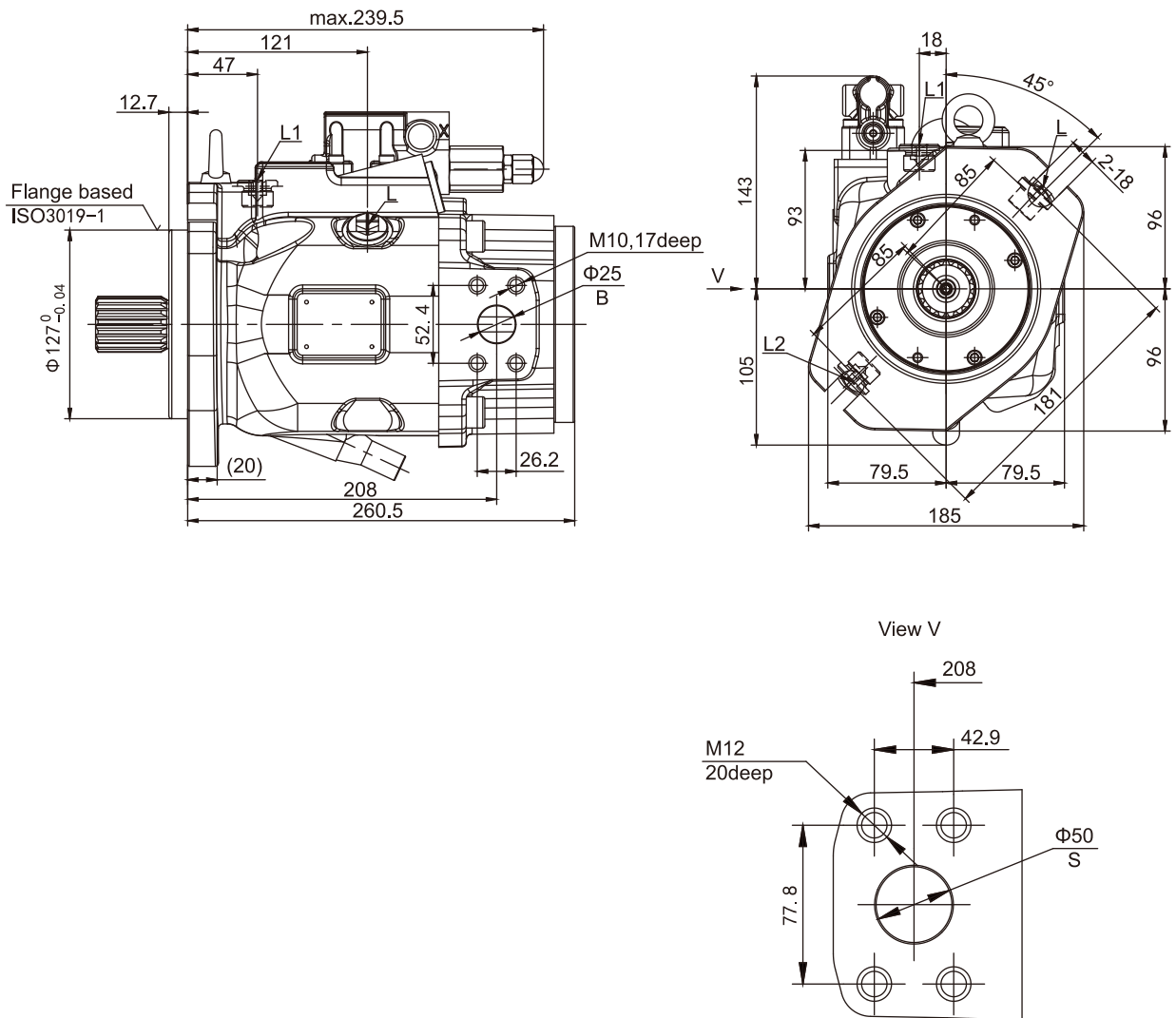

➤ Installation Dimensions, 85

DR-Hydraulic controller, clockwise rotation, mounting flange D, series 01

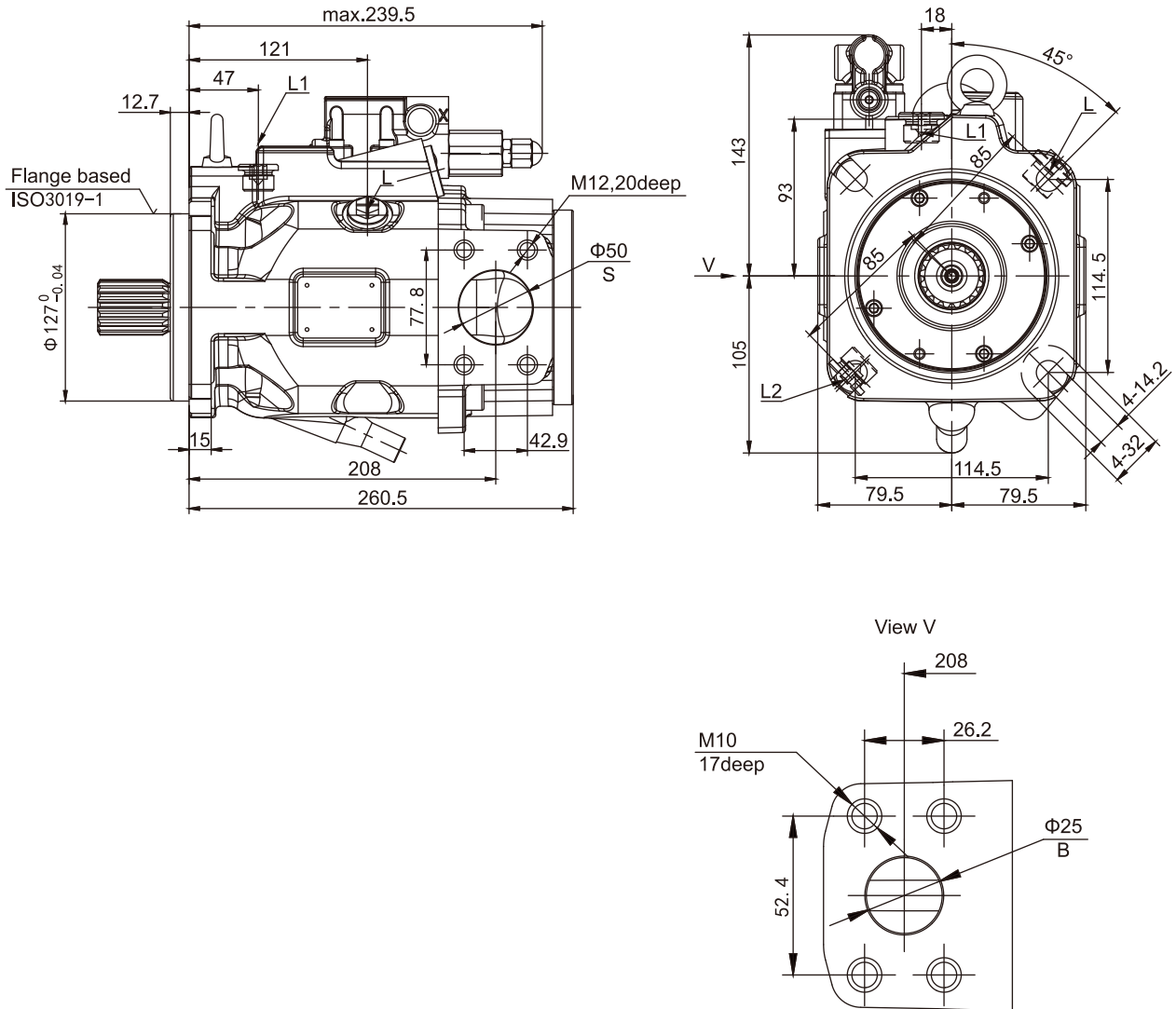

➤ Installation Dimensions, 85

DRF/DRS/DRSC-Pressure、Flow controller,mounting flange C,series 01

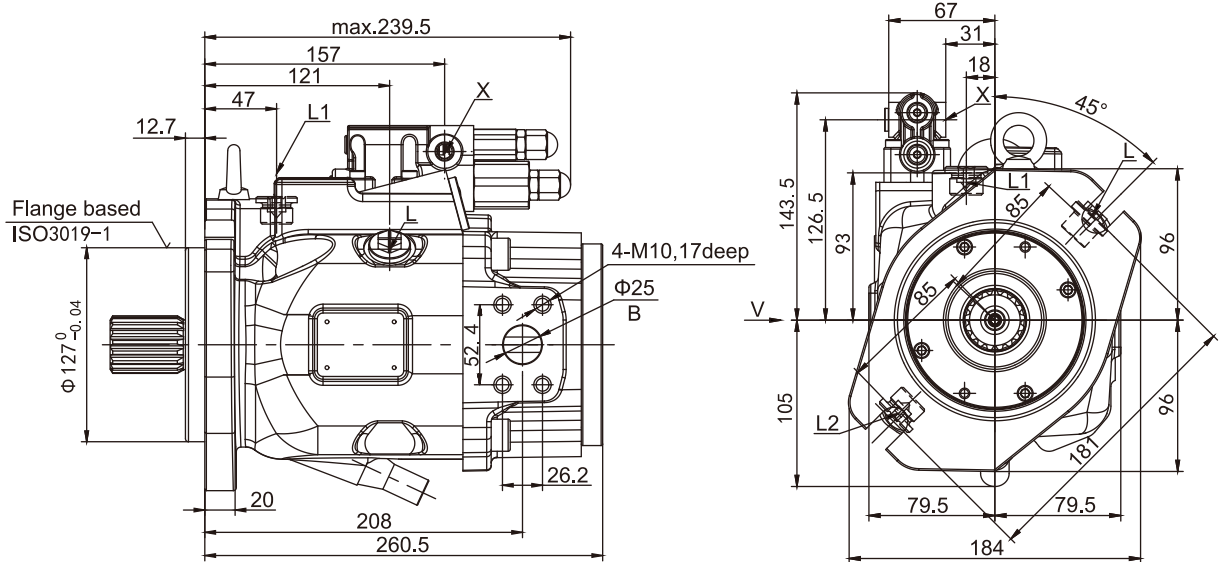

DRF/DRS/DRSC-Pressure、Flow controller,mounting flange D,series 01

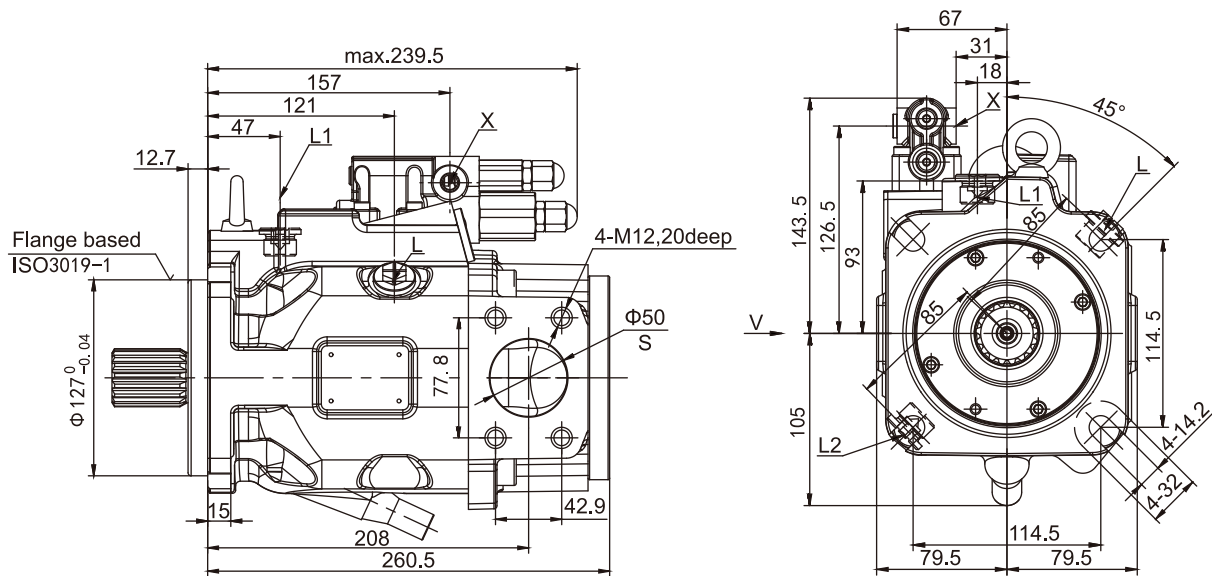

➤ Installation Dimensions, 85

LA.D.-Pressure, Flow, Power controller, mounting flange C, series 01

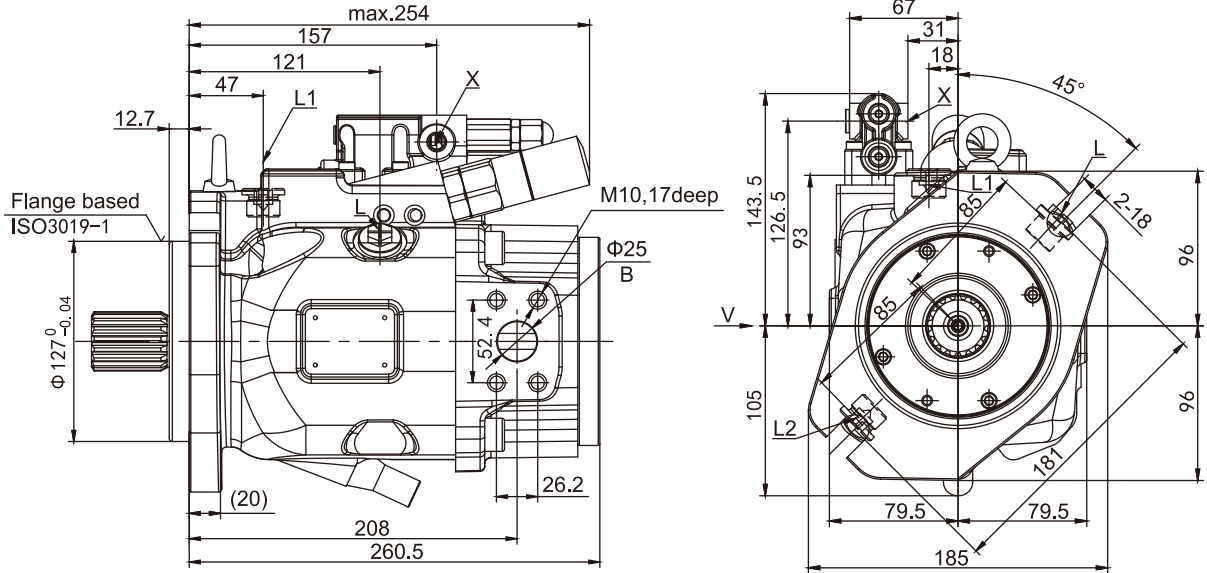

LA.D.-Pressure, Flow, Power controller, mounting flange D, series 01

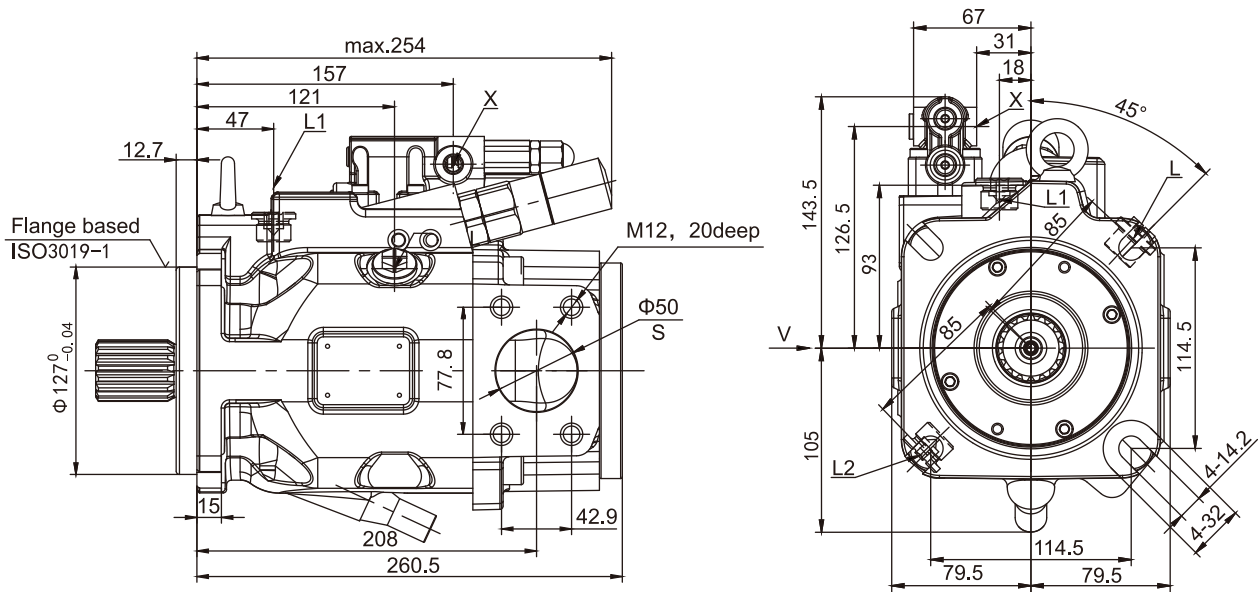

➤ Installation Dimensions, 85

LEDS.-Pressure, Flow, Power controller, mounting flange C, series 01

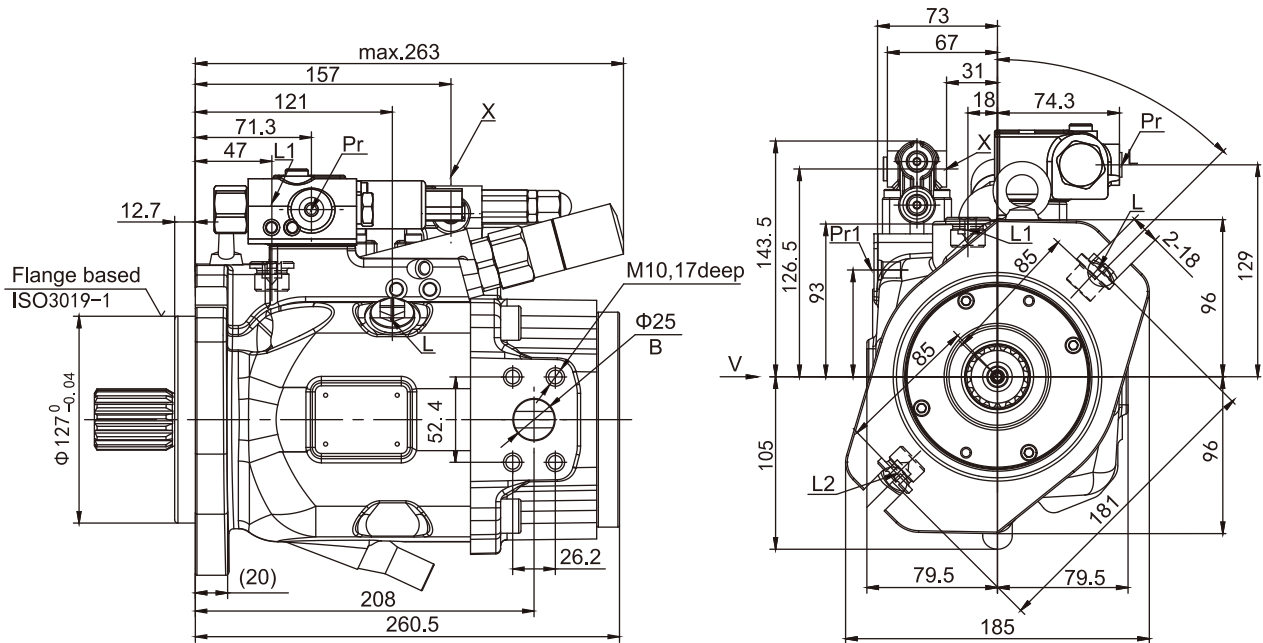

LEDS.-Pressure, Flow, Power controller, mounting flange D, series 01

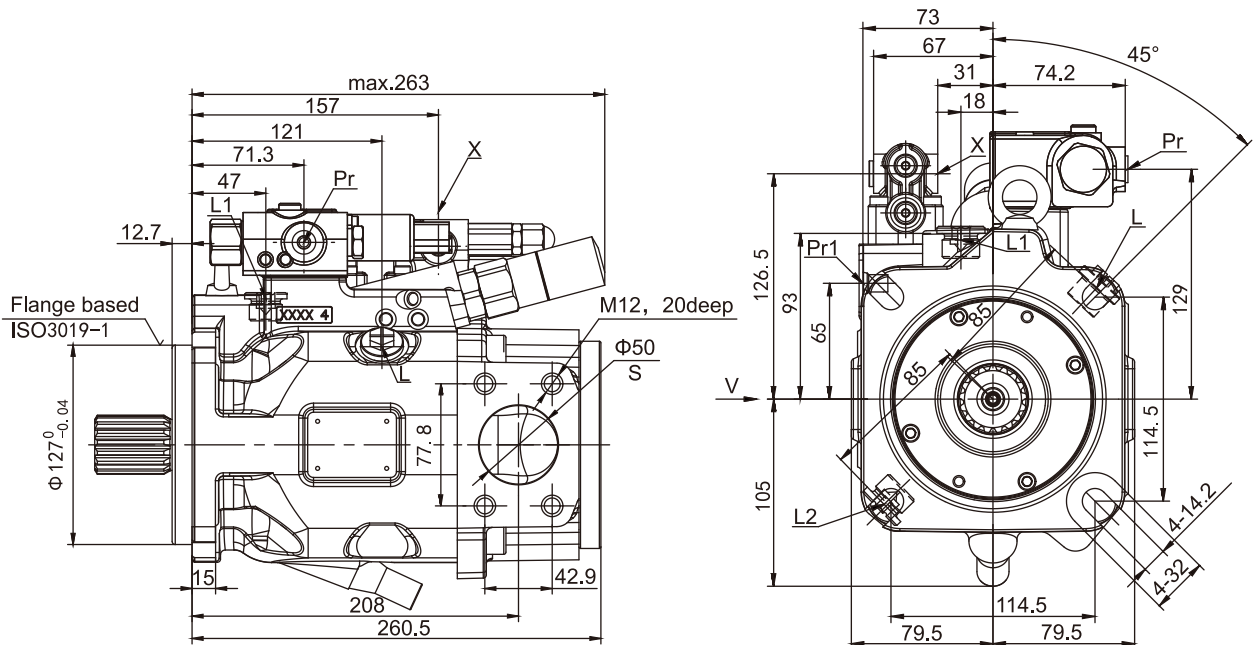

➤ Installation Dimensions, 85

Drive shaft

Splined shaft
Maximum allowable
input torque 630Nm
1 1/4" SAE J744
S3-14T 12/24DP

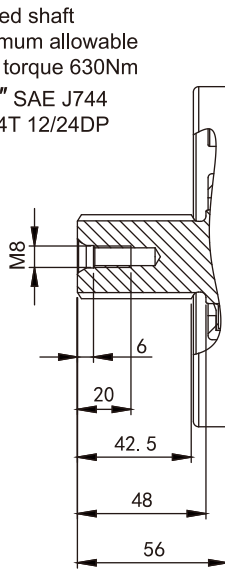

Splined shaft
Maximum allowable
input torque 1157Nm
1 1/2" SAE J744
S4-17T 12/24DP

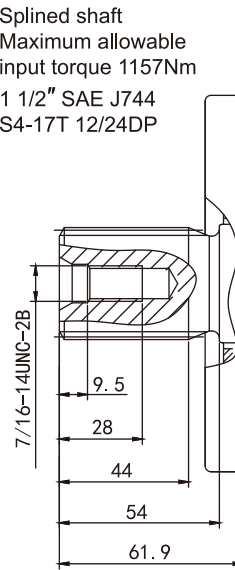

Port type

Port	Standard	Size	Code
L/L1/L2	SAE J1926	7/8-14UNF-2B, 13deep, O-ring seal	S
X	SAE J1926	7/16-20UNF-2B, 11.5deep, O-ring seal	
L/L1/L2	JIS B2351-1G	G1/2, O-ring seal	G
X	JIS B2351-1G	G1/4, 12deep, O-ring seal	

Working port

Port	Standard	Size	Code
B	SAE J518C	Φ25,M14,17deep	12
S		Φ50,M12,20deep	
B		Φ25,3/8-16NUF-2B,18deep	62
S		Φ50,1/2-13NUF-2B,19deep	

➤ **Dimensions through drive**

K01

Flange SAE J744-82-2(A)
Hub for splined shaft
ANSI B92.1a-1996
5/8" 9T 16/32DP

K01	40/45	63/72	85
A1	229	254.5	271.5
A2	9.5	9.2	11.7
A3	53	59	46.2

K68

Flange SAE J744-101-2(B)
Hub for splined shaft
ANSI B92.1a-1996
7/8" 13T 16/32DP

K15

Flange SAE J744-127-4(D)
Hub for splined shaft
ANSI B92.1a-1996
1 1/4" 14T 12/24DP

K07

Flange SAE J744-127-2(C)
Hub for splined shaft
ANSI B92.1a-1996
1 1/4" 14T 12/24DP

Flange SAE J744	Hub for splined shaft	Availability across sizes					Code
Diameter	Diameter	40	45	63	72	85	
82-2 (A)	5/8" 9T 16/32DP	●	●	●	●	●	K01
82-2 (A)	3/4" 11T 16/32DP	●	●	●	●	●	K52
101-2 (B)	7/8" 13T 16/32DP	●	●	●	●	●	K68
101-2 (B)	1" 15T 16/32DP	●	●	●	●	●	K04
127-4 (C)	1 1/4" 14T 12/24DP	○	○	○	○	●	K15
127-2 (C)	1 1/4" 14T 12/24DP	○	○	○	○	●	K07

➤ Allowable radial and axial forces on the drive shaft

Size		NG	40	45	63	72	85
Maximum radial force at a/2		$F_{q \max}(N)$	1500	1500	1700	1700	1700
Maximum axial force		$F_{ax \max}(N)$	1500	1500	2000	2000	3000

➤ Installation Instructions

General

The pump must be filled with hydraulic fluid during commissioning and operation.

To reduce noise, all connecting lines (inlet line, pressure line and case drain line) must be isolated from the reservoir with flexible components.

Do not install any check valve in the case drain line.

You must consult us before implementation in special cases.

➤ Vertical Installation (drive shaft upwards)

The installation below is for your reference:

a. Inside-reservoir installation

Fill the pump and lay it horizontal before installation.

a) If the minimum fluid level of the reservoir is equal to or higher than the mounting flange surface of the pump, plug port L, and open ports L1 and S; connect pipes to ports L1 and S as shown in FIG. 1.

b) If the minimum fluid level of the reservoir is below the mounting flange surface of the pump, connect pipes to ports L1 and S as shown in FIG. 2.

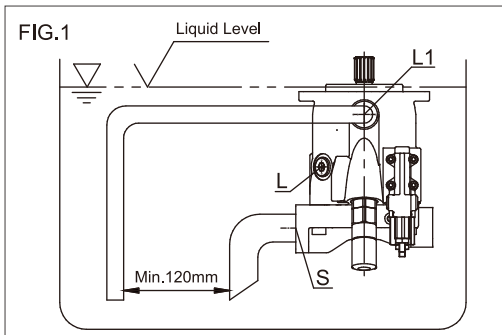

b. Outside-reservoir installation

Fill the pump and lay it horizontal before installation. See FIG. 2 for above-reservoir installation.

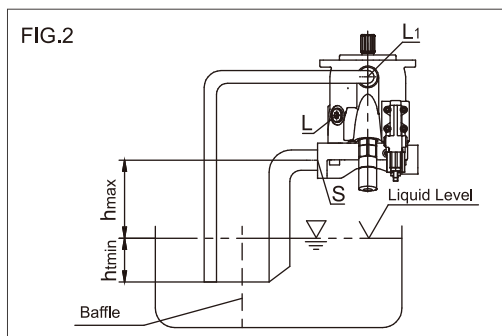

Restriction: Minimum inlet pressure under static and dynamic conditions $P_{abs \min} = 0.8 \text{ bar}$.

Note: Do not install the pump above the reservoir as far as possible to reduce noise.

The permissible suction height h results from the total pressure loss, but it should not exceed $h_{\max} = 800 \text{ mm}$ (pipe immersion depth $h_{\min} = 200 \text{ mm}$).

➤ Horizontal Installation

For horizontal installation, set port L or L1 on the top. The installation below is for your reference:

a. Inside-reservoir installation

1a) If the minimum fluid level of the reservoir is above the top of the pump, plug port L; you may open ports L1 and S, and connect pipes to the two ports (as shown in FIG. 3).

2a) If the minimum fluid level of the reservoir is below the top of the pump, plug port L; see FIG.4 for pipe connection of port L1 and possibly port S.

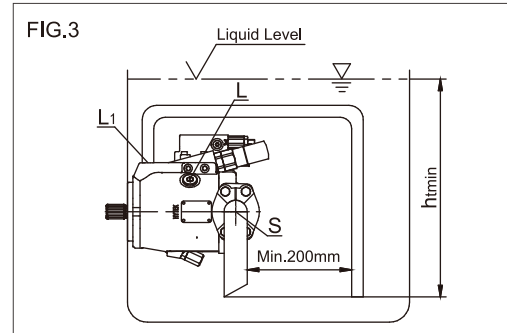

b. Outside-reservoir installation

Fill the pump before commissioning.

Connect pipes to port S and the top port L or L1.

1b) See FIG. 4 for above-reservoir installation.

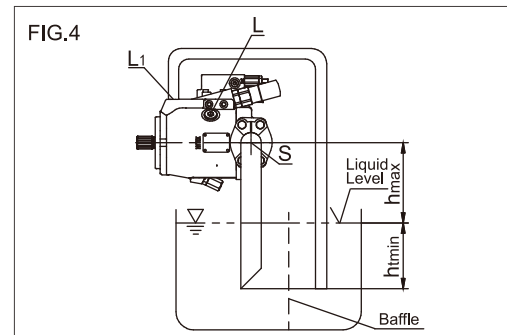

2b) Below-reservoir installation

See FIG. 5 for pipe connection of ports L and S. Port L is plugged.

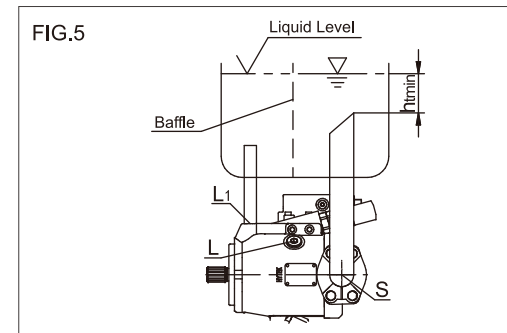

Since 2002

Over twenty years of deep cultivation in the field of hydraulic Solutions

HYTEK is a high technology enterprise integrating R&D, production, sales and service of hydraulic power products. Provides professional hydraulic transmission control products and solutions for construction machinery, road machinery, material handling machinery, agricultural and forestry machinery, industrial equipment and other fields.

After more than 20 years of continuous R&D, technological innovation, market development and application services, technical level and the scale of production and sales have been on the forefront of the industry.

Hytek has been committed to helping the development of subdivided industries with innovative hydraulic technology, "focusing on the challenges and pressures of customers, providing competitive products and solutions, reducing costs and increasing efficiency for customers, and continuously creating maximum value".

Product Series

- Open Circuit Pump
- Closed Circuit Pump
- Fixed Displacement Motor
- Variable Displacement Motor
- Hydrostatic Transmission Unit
- Internal Gear Pump
- Vane Pump
- Proportional valve/
Industrial Hydraulic Valve

Please visit the official website : en.hytek.cn

HYTEK POWER CO.,LTD.

No.156,West Yuele Street,Lucheng District,Wenzhoucity 325029,Zhejiang,CHINA

Email: globalsales@hytek.cn

HYTEK-REV1.1 09/2025

If there are any other modifications,no further notice will be given.