

Axial Piston Variable Pump HP1VO Series 01

Size: 60~260 mL/r
 Rated pressure: 35 MPa
 Max. pressure: 40 MPa



Features



- Axial variable pump of swashplate design for hydrostatic drives in open circuits
- For automatic suction, it works with pressurized reservoir or integrated charge pump (centrifugal pump)
- The output flow is proportional to the drive speed and infinitely varied between the maximum value and zero
- Various control options to satisfy different operating requirements
- Power control externally adjustable even during operation of the pump
- The through drive can connect gear pumps and axial piston pumps of up to the same size, i.e. 100% through drive

Contents



- Model Code.....02
- Structure.....06
- Technical Data.....09
- DR Pressure Control.....11
- LR Power Control.....13
- EP Electric Controller with Proportional Solenoid.....20
- Installation Dimensions,56.....22
- Installation Dimensions,95/115/125.....25
- Installation Dimensions,130/145/165.....29
- Installation Dimensions,190.....33
- Installation Dimensions,260.....36
- Installation Dimensions-Through Drive.....38
- Installation Instructions.....41

> Model Code

	b	c	A	B	/	I	K	-	M	N	P	R	S	W	X	Z
HP1V		O			/	01		-				12				-

Axial piston unit

—	Swashplate design, variable piston pump	HP1V
---	---	------

Charge pump (impeller)

b		60	95	115	125	130	145	165	190	210	260	
	Without charge pump (without code)	●	●	●	●	●	●	●	○	○	○	
	With charge pump	○	●	●	●	●	●	●	●	○	●	A

Operation

c	Open circuit	O
---	--------------	---

Displacement

A	Geometric displacement, in mL/r	60	95	115	125	130	145	165	190	210	260
---	---------------------------------	----	----	-----	-----	-----	-----	-----	-----	-----	-----

Variable control method

B	Power control					60	95	115	125	130	145	165	190	210	260			
			Pressure control	With load sensitive control	DRS			○	●	●	●	●	●	●	●	●	●	DRS
				With pressure cut-off and load sensitive control	LR	D	S	●	●	●	●	●	●	●	●	○	○	LRDS
				With pressure cut-off control	LR	D		○	○	○	○	○	○	○	●	●	○	LRD
				With load sensitive control	LR		S	○	●	●	●	●	●	●	○	○	○	LRS
				With pressure cut-off/ electric proportional displacement control	U=12 V	LR	D	U1 ¹⁾	●	○	○	○	○	○	○	○	○	LRDU1
			U=24 V		LR	D	U2 ¹⁾	●	●	●	●	●	●	●	●	●	●	LRDU2
				With pressure cut-off/ hydraulic proportional displacement control	Δp= 2.5 MPa	LR	D	H2 ²⁾	○	●	●	●	●	●	●	●	●	LRDH2
					Δp= 1.0 MPa	LR	D	H6 ²⁾	○	●	●	●	●	●	○	○	○	LRDH6
				With pilot pressure power control/ pressure cut-off/ hydraulic proportional displacement control	Δp= 2.5 MPa	LG1 ³⁾	D	H2 ²⁾	○	●	●	●	●	●	○	○	○	LG1DH2
				With load sensitive control	U=24 V	LE2 ⁴⁾		S	○	●	●	●	●	●	●	●	○	LE2S
					U=24 V	LE2 ⁴⁾		S2 ⁵⁾	○	●	●	●	●	●	●	●	○	LE2S2
				With pressure cut-off and load sensitive control	U=12 V	LE3 ⁶⁾	D	S	○	●	●	●	●	●	●	●	○	LE3DS
					U=24 V	LE4 ⁶⁾	D	S	○	●	●	●	●	●	●	●	○	LE4DS
				Electric proportional displacement control	With pressure cut-off	U=12 V	EP1 ⁷⁾	D		○	●	●	●	●	●	○	○	EP1D
	U=24 V	EP2 ⁷⁾	D				○	●	●	●	●	●	●	○	EP2D			

1) : Electrical proportional displacement control

3) : Pilot pressure negative proportional power control

5) : Electrical negative proportional load sensitivity control

7) : Electrical proportional displacement control

2) : Hydraulic proportional displacement control

4) : Electrical negative proportional power control

6) : Electrical proportional power control

> Model Code

	b	c	A	B		I	K		M	N	P	R	S	W	X	Z
HP1V		O			/	01		-				12				-

Series

I	Series 01	01
---	-----------	----

Direction of rotation (viewed on drive shaft)

K		60	95	115	125	130	145	165	190	210	260	
	CW (right-hand)	●	●	●	●	●	●	●	●	●	●	R
	CCW (left-hand)	●	●	●	●	●	●	●	●	●	●	L

Sealing material

M		60	95	115	125	130	145	165	190	210	260	
	NBR seal + FKM Shaft seal	●	●	●	●	●	●	●	●	●	●	N
	NBR seal + NBR Shaft seal	●	●	●	●	●	●	●	●	●	●	P

Drive shaft

N	Without charge pump HP1VO	Splined shaft ANSI B92.1a	60	95	115	125	130	145	165	190	210	260		
			—	●	●	●	○	○	○	○	○	○	—	U
			●	●	●	●	●	●	●	○	○	○	—	S
		●	○	○	○	○	○	○	○	○	○	—	T	
		●	●	●	●	●	●	●	●	●	●	—	Z	
	With charge pump HP1VAO	Splined shaft ANSI B92.1a	60	95	115	125	130	145	165	190	210	260		
			—	●	●	●	●	●	●	●	●	●	○	S
			—	—	—	—	○	○	○	●	●	○	○	H
		—	○	○	○	●	●	●	●	●	●	○	T	
		—	○	○	○	●	●	●	●	●	●	●	Z	
Parallel keyed shaft DIN 6885	60	95	115	125	130	145	165	190	210	260				
	●	●	●	●	●	●	●	○	○	—	—	P		
		60	95	115	125	130	145	165	190	210	260			
		—	○	○	○	●	●	●	●	●	○	○	P	

Mounting flange

P		60	95	115	125	130	145	165	190	210	260	
	SAE J744-127-2(C)-hole ⁸⁾	●	—	—	—	—	—	—	—	—	—	C
	SAE J744-152-4(D)-hole ⁹⁾	—	●	●	●	●	●	●	—	—	—	D
	SAE J744-165-4(E)-hole ¹⁰⁾	—	—	—	—	—	—	—	●	●	●	

Working ports

R		60	95	115	125	130	145	165	190	210	260	
	SAE pressure port and suction port, opposite	●	●	●	●	●	●	●	●	●	●	12

8) : 2*Φ14, Φ127h8

9) : 4*Φ22, Φ152.4h8

10) : 4*Φ22, Φ165.1h8

> Model Code

	b	c	A	B	/	I	K	M	N	P	R	S	W	X	Z
HP1V		O			/	01		-			12				-

Through drive¹¹⁾

			60	95	115	125	130	145	165	190	210	260			
S	Without charge pump(HP1VO)			60	95	115	125	130	145	165	190	210	260		
	Without adapter plate			●	●	●	●	●	●	●	●	●	—	N00	
	Flange SAE J744-82-2(A)	Splined shaft ANSI B92.1a	5/8" 9T 16/32DP	●	●	●	●	●	●	●	○	○	—	K01	
			3/4" 11T 16/32DP	●	●	●	●	○	○	○	○	○	○	—	K52
	Flange SAE J744-101-2 (B)	Splined shaft ANSI B92.1a	7/8" 13T 16/32DP	●	●	●	●	●	●	●	○	○	—	K02	
			1" 15T 16/32DP	●	●	●	●	●	●	●	○	○	—	K04	
		Splined shaft DIN 5480	W35x2x30x16x9g	●	○	○	○	●	●	●	○	○	—	K79	
	Flange SAE J744-127-2 (C)	Splined shaft ANSI B92.1a	1 1/4" 14T 12/24DP	●	●	●	●	●	●	●	○	○	—	K07	
			1 1/2" 17T 12/24DP	○	○	○	○	●	●	●	○	○	—	K24	
		Splined shaft DIN 5480	W30x2x30x14x9g	○	●	●	●	●	●	●	○	○	—	K80	
			W35x2x30x16x9g	○	●	●	●	●	●	●	○	○	—	K61	
	Flange SAE J744-152-4 (D)	Splined shaft ANSI B92.1a	1 1/4" 14T 12/24DP	—	●	●	●	●	●	●	○	○	—	K86	
			1 3/4" 13T 8/16DP	—	○	○	○	●	●	●	○	○	—	K17	
		Splined shaft DIN 5480	W40x2x30x18x9g	—	○	○	○	○	○	○	○	○	○	—	K81
			W45x2x30x21x9g	—	●	●	●	●	●	●	○	○	—	K82	
	W50x2x30x24x9g		—	○	○	○	●	●	●	○	○	—	K83		
	Flange SAE J744-165-4 (E)	Splined shaft ANSI B92.1a	1 3/4" 13T 16/32DP	—	—	—	—	—	—	—	○	○	—	K72	
		Splined shaft DIN 5480	W45x2x30x21x9g	—	—	—	—	—	—	—	○	○	—	K84	
	With charge pump(HP1VAO)			60	95	115	125	130	145	165	190	210	260		
	Without adapter plate			—	●	●	●	●	●	●	●	●	●	●	N00
	Flange SAE J744-82-2 (A)	Splined shaft ANSI B92.1a	5/8" 9T 16/32DP	—	○	○	○	●	●	●	●	●	○	K01	
			3/4" 11T 16/32DP	—	○	○	○	○	○	○	○	○	○	K52	
	Flange SAE J744-101-2 (B)	Splined shaft ANSI B92.1a	7/8" 13T 16/32DP	—	○	○	○	●	●	●	●	●	●	K02	
			1" 15T 16/32DP	—	○	○	○	●	●	●	●	●	○	K04	
		Splined shaft DIN 5480	W35x2x30x16x9g	—	○	○	○	●	●	●	●	●	○	K79	
	Flange SAE J744-127-2 (C)	Splined shaft ANSI B92.1a	1 1/4" 14T 12/24DP	—	○	○	○	●	●	●	●	●	○	K07	
1 1/2" 17T 12/24DP			—	○	○	○	●	●	●	○	○	○	K24		
Splined shaft DIN 5480		W30x2x30x14x9g	—	○	○	○	●	●	●	○	○	○	K80		
		W35x2x30x16x9g	—	○	○	○	●	●	●	●	●	○	K61		
Flange SAE J744-152-4 (D)	Splined shaft ANSI B92.1a	1 1/4" 14T 12/24DP	—	○	○	○	●	●	●	●	●	○	K86		
		1 3/4" 13T 8/16DP	—	○	○	○	●	●	●	●	●	○	K17		
	Splined shaft DIN 5480	W40x2x30x18x9g	—	○	○	○	○	○	○	○	○	○	K81		
		W45x2x30x21x9g	—	○	○	○	●	●	●	●	●	○	K82		
W50x2x30x24x9g		—	○	○	○	●	●	●	●	●	○	K83			
Flange SAE J744-165-4 (E)	Splined shaft ANSI B92.1a	1 3/4" 13T 16/32DP	—	—	—	—	—	—	—	○	○	○	K72		
	Splined shaft DIN 5480	W45x2x30x21x9g	—	—	—	—	—	—	—	●	●	○	K84		

¹¹⁾ Splines standard ANSI B92.1-1970, class 6, shaft S is first used on combination pumps

➤ Model Code

	b	c	A	B		I	K		M	N	P	R	S	W	X		Z
HP1V		O			/	01		-				12				-	

Swivel angle indicator

W		60	95	115	125	130	145	165	190	210	260	
	Without swivel angle indicator (without code)	●	●	●	●	●	●	●	●	●	●	
	With optical swivel angle indicator	—	○	○	○	○	○	○	○	○	○	V
	With electronic swivel angle indicator	—	○	○	○	○	○	○	○	○	○	R

Solenoid connector

X		60	95	115	125	130	145	165	190	210	260	
	Without solenoid (without code)	●	●	●	●	●	●	●	●	●	●	
	DEUTSCH molded connector, 2-pin, without suppressor diode ¹²⁾	●	●	●	●	●	●	●	●	●	●	P

Special configuration

Z		60	95	115	125	130	145	165	190	210	260	
	Without special configuration(without code)	●	●	●	●	●	●	●	●	●	●	
	Special configuration	—	○	○	○	○	○	○	○	○	○	***

¹²⁾Model: Deutsch DT04-2P

- Available
- On request
- Not available
- Recommended model

> Structure

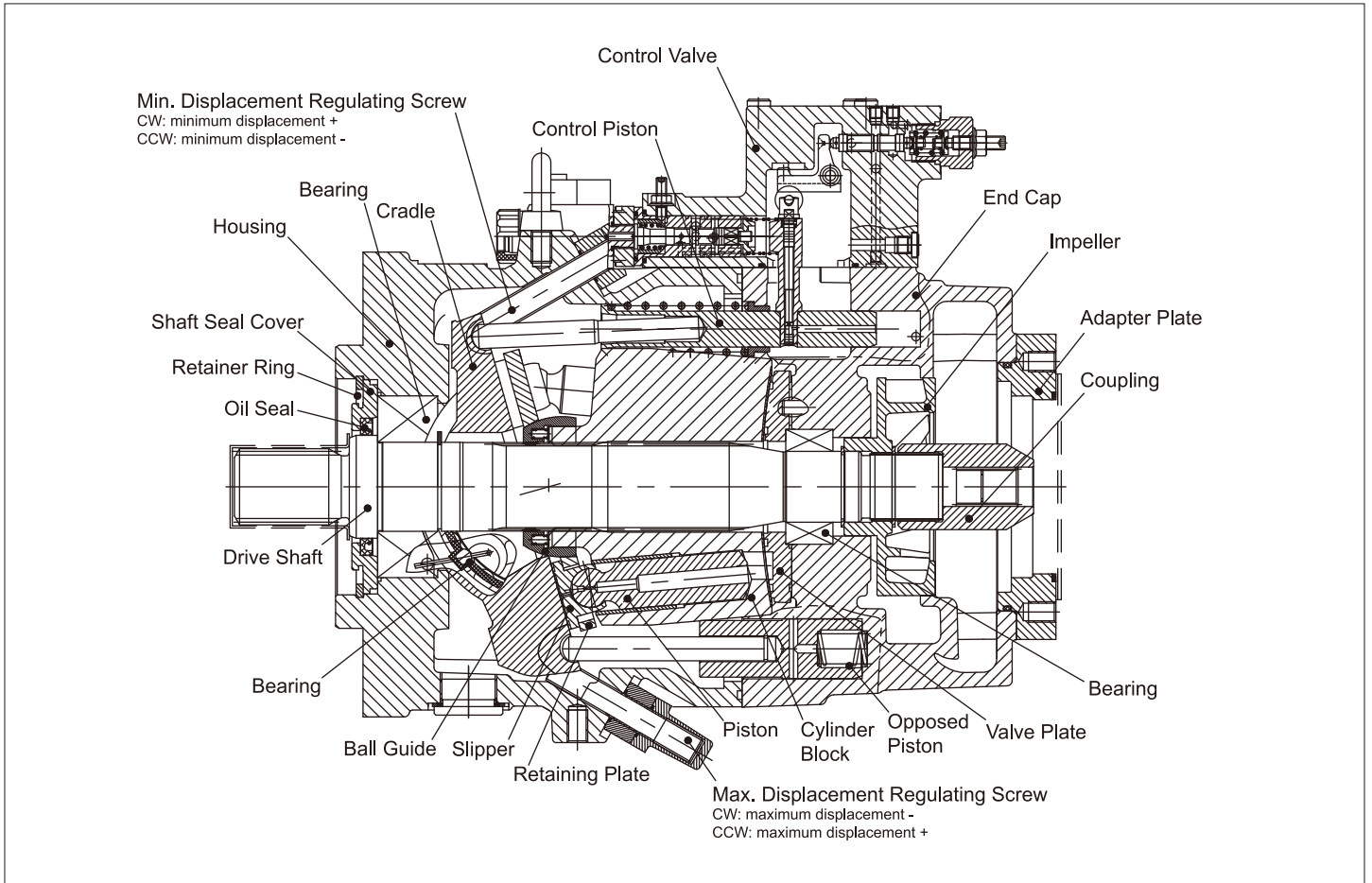

> Hydraulic Fluid

Mineral oil

> Working Viscosity

In order for the optimum efficiency and service life, it is recommended to select the working viscosity at working temperature within the range below:

$$V_{opt} = \text{optimal working viscosity } 16...36 \text{ mm}^2/\text{s}$$

It is subject to the reservoir temperature of an open circuit.

> Limit Viscosity

Limit viscosity:

$$V_{min} = 5 \text{ mm}^2/\text{s}$$

Short-term operation ($t < 3 \text{ min}$)

Permissible maximum temperature $t_{max} = +115^\circ\text{C}$

$$V_{max} = 1600 \text{ mm}^2/\text{s}$$

Short-term operation ($t < 3 \text{ min}$)

Cold start ($p \leq 3 \text{ MPa}$, $n \leq 1000 \text{ rpm}$, $t_{min} = -140^\circ\text{C}$)

Only for no-load start, it must reach the optimum working temperature in 15 min.

Note:

Local temperature (e.g.: bearing area) shall not exceed the maximum fluid temperature 115°C . The temperature in the bearing area is no more than 5 K higher than average case drain temperature.

It depends on the pressure and speed.

Take special actions within the range of -40°C to -25°C (at cold start).

Please consult us for the details.

> Selection Diagram

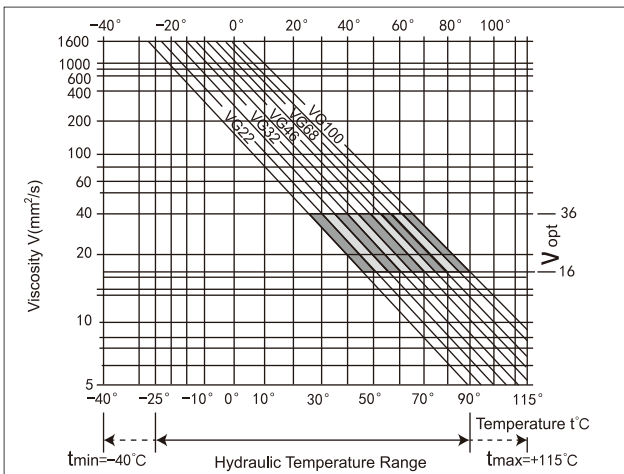

> Instructions on Selection of Hydraulic Fluid

The working temperature dependent on the ambient temperature is required for correct selection of hydraulic fluid. It refers to the circuit temperature of a closed circuit and the reservoir temperature of an open circuit.

The hydraulic fluid should be so selected that the working viscosity in the working range is within the optimum range (V_{opt} , the shaded area on the selection diagram). The higher viscosity is recommended under the same conditions.

For example:

At an ambient temperature of $X^\circ\text{C}$, the working temperature of the circuit is 60°C . The viscosity within the optimum range (V_{opt} , shaded area) is VG46 or VG68 and the latter should be selected.

Note:

The case drain temperature depends on the pressure and speed, and it is always higher than the circuit temperature. The temperature at any point within the system should not exceed $+115^\circ\text{C}$. Please contact us if the above condition cannot be maintained due to extreme working conditions.

> Filtration

Finer filtration improves the cleanliness level of the hydraulic fluid, thus increasing the service life of the axial piston unit. To ensure normal operation of the axial piston unit, a cleanliness level of at least 20/18/15 according to ISO 4406 is to be maintained.

When the hydraulic fluid has a high temperature ($+90^\circ\text{C}$ to $+115^\circ\text{C}$), the cleanliness level should at least reach 19/17/14 according to ISO 4406. Please contact us if the above cleanliness level cannot be maintained.

> Maximum Permissible Speed (speed limit)

Permissible rotational speed by increasing inlet pressure p_{abs} at suction port S or $V_g \leq V_{g \text{ max}}$

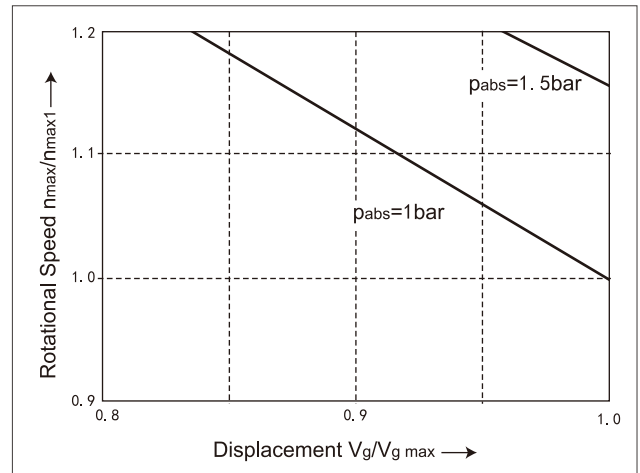

> Working Pressure Range

Input

Absolute pressure at port S

Without charge pump

$p_{abs \text{ min}}$ _____ 0.8bar

$p_{abs \text{ max}}$ _____ 30bar

Please consult us if the pressure $> 5 \text{ bar}$.

With charge pump

$P_{abs \text{ min}}$ _____ 0.6bar

$P_{abs \text{ max}}$ _____ 2bar

Output

Pressure at port A or B

Without charge pump

p_N _____ 350bar

p_{max} _____ 400bar

Rated pressure: maximum design pressure when the fatigue strength is guaranteed.

Maximum pressure: permissible maximum working pressure in short time ($t < 1 \text{ s}$).

> Case Drain Pressure

Case drain pressures at ports T1 and T2 may be 1.2bar higher than inlet pressure at port S, but it is no greater than

$p_{Labs, max}$ _____ 2bar

Unrestricted full-size case drain lines that need to be directly connected to the reservoir.

> Minimum Working Pressure

The required minimum working pressure $p_{B \min}$ for pump working lines depends on the rotational speed, swivel angle and displacement (see the table below).

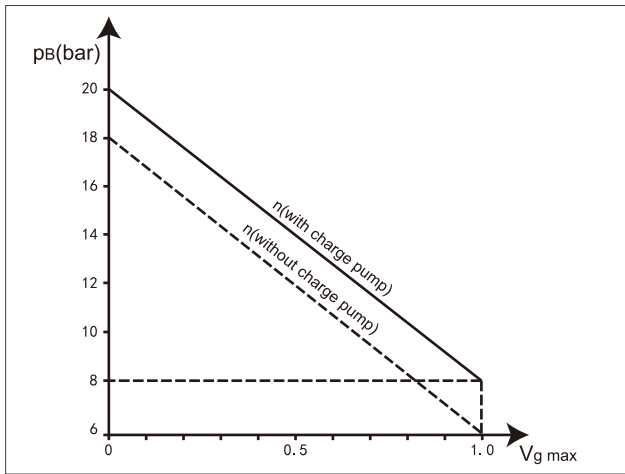

> Oil Seal

Permissible pressure load
 The service life of the shaft seal depends on the pump speed and case drain pressure. It is recommended that the average lasting case drain pressure at working temperature is no greater than 3bar absolute pressure (as the speed falls, the maximum permissible case drain pressure is 6bar) and the short-term ($t < 0.1s$) permissible absolute pressure peak may reach 10bar. The service life of the shaft seal decreases with increasing frequency of pressure peaks.

> Temperature Range

The FKM shaft seal may be used for case temperatures from $-25\text{ }^{\circ}\text{C}$ to $+115\text{ }^{\circ}\text{C}$.
 The NBR shaft seal may be used for case temperatures from $-40\text{ }^{\circ}\text{C}$ to $+90\text{ }^{\circ}\text{C}$.
 Note: In applications below $-25\text{ }^{\circ}\text{C}$, an NBR shaft seal is required.

> Charge Pump (with impeller)

The charge pump is a circulating pump with which the HP1VAO series can be operated at higher speeds. The charge pump also facilitates cold starting at low temperatures and high viscosity of the hydraulic fluid. Hence, there is no need to pressurize the reservoir in most cases. For use of a charge pump, the maximum permissible reservoir pressure is 2bar.

> Case Flushing

The case should be flushed via T1/T2 or R if the variable pump which has a control valve with EP/HD and DR or stroke limiter (U./H.) operates for a long time ($t > 10\text{min}$) at zero position or at low pressure ($< 15\text{bar}$).

See the table below for the flushing flow:

Size	60	95	115	125	130	145	165	190	260
q_v flush (L/min)	3	4	4	4	4	4	4	5	6

Pumps (HP1VAO) with a charge pump require no flushing as partial boost flow enters the case. Be careful when the case drain flow exceeds the total leakage and control flow of the rotary assembly.

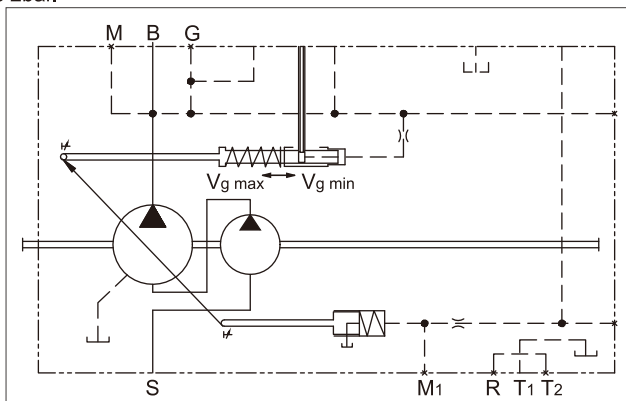

► Technical Data

Size HP1VO			Unit		60	95	115	125	130	145	165	190	260
Displacement		$V_{g \max}$	mL/r	58.5	93.5	115	125	130	145	165	-	-	
		$V_{g \min}$	mL/r	0	0	0	0	0	0	0	0	-	-
Speed	Maximum at $V_{g \max}$ ¹⁾	n_{\max}	r/min	2700	2350	2350	2100	2100	2200	2100	-	-	
	Maximum at $V_g \leq V_{g \max}$ ³⁾	$n_{\max 1}$	r/min	3250	2780	2780	2500	2500	2500	2500	-	-	
Flow	At n_{\max} and $V_{g \max}$	$q_{v \max}$	L/min	158	220	270	262	273	319	346	-	-	
Power	At $q_{v \max}$ and $\Delta p=350\text{bar}$	P_{\max}	KW	92	128	158	153	159	186	202	-	-	
Torque	At n_{\max} and $\Delta p=350\text{bar}$	T_{\max}	Nm	326	521	641	696	724	808	919	-	-	
Moment of inertia of drive shaft(0.0001)		J_{TW}	kgm ²	0.0082	0.0173	0.0173	0.0173	0.0318	0.0341	0.0341	-	-	
Max. angular acceleration ⁴⁾		α	rad/s ²	17500	13000	13000	13000	10500	9000	9000	-	-	
Case volume		V	L	1.35	2.1	2.1	2.1	2.9	2.9	2.9	-	-	
Weight		m	KG	40	53	53	53	66	76	76	-	-	

Size HP1VAO			Unit		60	95	115	125	130	145	165	190	260
Displacement		$V_{g \max}$	mL/r	-	93.5	115	125	130	145	165	193	260	
		$V_{g \min}$	mL/r	-	0	0	0	0	0	0	0	0	0
Speed	Maximum at $V_{g \max}$ ²⁾	n_{\max}	r/min	-	2500	2500	2500	2500	2500	2500	2500	2500	2300
	Maximum at $V_g \leq V_{g \max}$ ³⁾	$n_{\max 1}$	r/min	-	2500	2500	2500	2500	2500	2500	2500	2500	2300
Flow	At n_{\max} and $V_{g \max}$	$q_{v \max}$	L/min	-	234	287	312	325	363	412	483	598	
Power	At $q_{v \max}$ and $\Delta p=350\text{bar}$	P_{\max}	KW	-	136	167	182	190	211	240	281	349	
Torque	At n_{\max} and $\Delta p=350\text{bar}$	T_{\max}	Nm	-	521	641	696	724	808	919	1075	1448	
Moment of inertia of drive shaft(0.0001)		J_{TW}	kgm ²	-	0.0173	0.0173	0.0173	0.0337	0.036	0.036	0.0577	0.0895	
Max. angular acceleration ⁴⁾		α	rad/s ²	-	13000	13000	13000	10500	9000	9000	6800	4800	
Case volume		V	L	-	2.1	2.1	2.1	2.9	2.9	2.9	3.8	4.6	
Weight		m	KG	-	55	56	57	72	73	74	104	138	

1) : The values apply at absolute pressure(p_{abs})=1bar at suction port S and mineral based hydraulic fluids.

2) : The values apply at absolute pressure(p_{abs}) \geq 0.8bar at suction port S and mineral based hydraulic fluids.

3) : The values apply at $V_g \leq V_{g \max}$ or for increased inlet pressure(p_{abs}) at suction port S.

4) : -The valid range is between 0 and the maximum permissible speed.

It is applicable for external excitation (e.g. engine 2 to 8 times rotary frequency, cardan shaft twice the rotary frequency).

-The limit value is only valid for a single pump.

-The load on the connecting pieces must be considered.

Note: Operation above the maximum values or below the minimum values may result in a loss of function, reduced service life or the destruction of the axial piston unit. The permissible values may be calculated.

> Specification Calculation

Flow	$q_v = \frac{V_g \cdot n \cdot \eta_v}{1000}$	[L/min]	V_g = Displacement, mL/r
			Δp = Differential pressure, MPa
Torque	$T = \frac{V_g \cdot \Delta p}{2 \cdot \pi \cdot \eta_{mh}}$	[Nm]	n = Speed, r/min
			η_v = Volumetric efficiency
Power	$P = \frac{2 \pi \cdot T \cdot n}{60000} = \frac{q_v \cdot \Delta p}{60 \cdot \eta_t}$	[KW]	η_{mh} = Mechanical-hydraulic efficiency
			η_t = Total efficiency

DR-Pressure Control

DR With pressure cut-off control

The pressure controller can maintain constant pressure of the hydraulic system within its control range despite changes in the flow. The variable pump only supplies as much hydraulic fluid as required by the actuator. If the working pressure exceeds the set point of the integrated pressure control valve, the pump will automatically swivel back until the pressure deviation is corrected.

Start position of depressurized state: $V_{g \max}$

Setting range from 50 to 350 bar.

Characteristic Curve

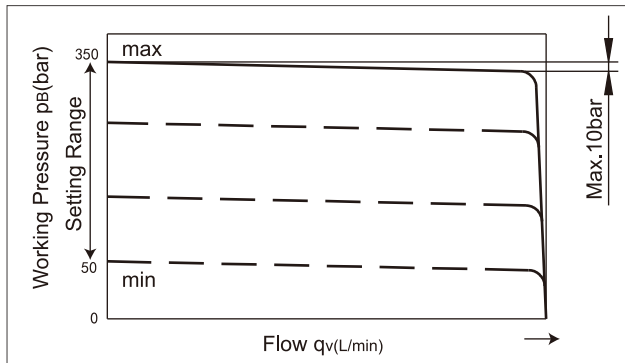

Circuit diagram

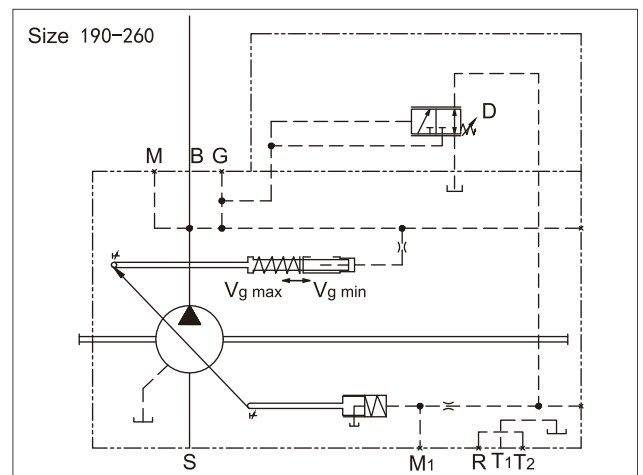
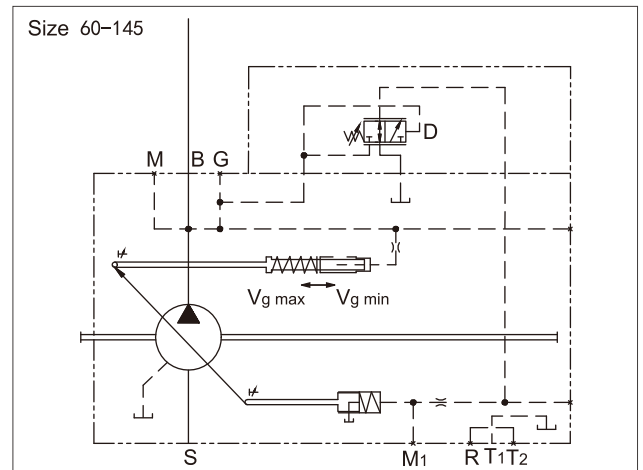

DR-Pressure Control

DRS pressure control with load sensing

The load sensing controller works as a load-pressure controlled flow controller and adjusts the displacement of the pump to the flow required by the actuator.

The flow depends on the cross section of the external metering orifice (1) which is located between the pump outlet and the actuator. The flow is independent of the load pressure below the setting of the power curve and power cut-off and within the control range of the pump.

The metering orifice is usually a separately located load sensing directional valve (control block). The spool position of the directional valve determines the opening cross section of the metering orifice and thus the flow of the pump.

The load sensing controller compares the pressures upstream and downstream of the metering orifice and keeps the pressure drop (differential pressure Δp) through the orifice and thus the flow constant.

If the differential pressure Δp at the metering orifice increases, the pump swivels back (toward $V_{g \text{ min}}$).

If the differential pressure Δp falls, the pump swivels out (toward $V_{g \text{ max}}$) until equilibrium at the metering orifice is restored.

$$\Delta p_{\text{hole}} = p_{\text{pump}} - p_{\text{actuator}}$$

Setting range of Δp : 14 to 25 bar

Setting of standard differential pressure: 18 bar. Please specify in plain text when ordering.

The standby pressure in zero stroke operation (metering orifice closed) is slightly higher than Δp setting.

(1) The metering orifice (control block) is not included in the scope of supply of pumps.

Characteristic Curve

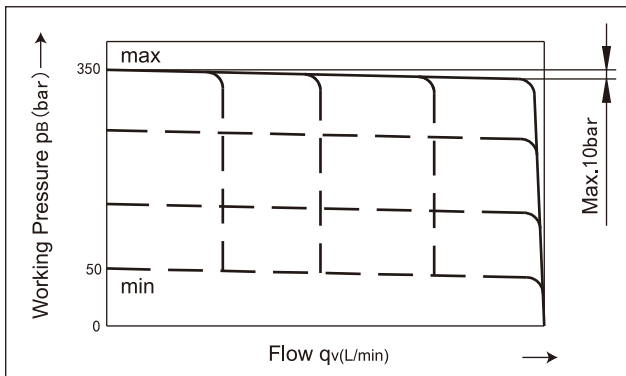

Circuit diagram

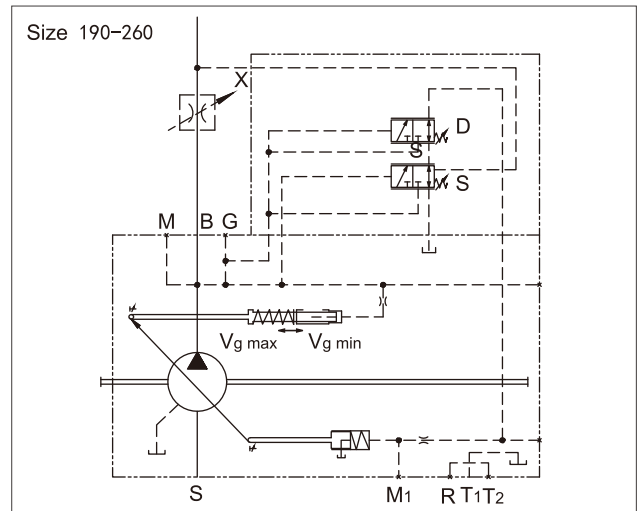
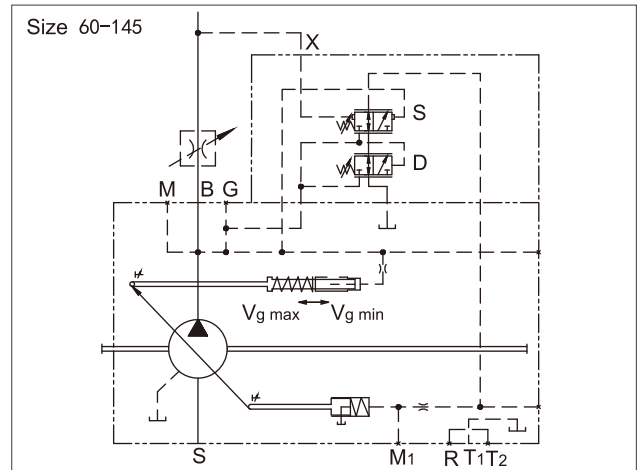

➤ LR-Power Control

LR Power Control

The power controller regulates the displacement of the pump depending on the working pressure so that a given drive power is not exceeded at constant drive speed.

$$p_B \cdot V_g = \text{constant}$$

p_B : working pressure

V_g : displacement

The precise control with a hyperbolic characteristic curve realizes an optimum utilization of available power. The working pressure acts on a rocker via a measuring spool. An externally adjustable spring force counteracts this and it determines the power setting.

If the working pressure exceeds the set spring force, the rocker actuates the control valve and the pump swivels back (toward $V_{g \text{ min}}$). The length of the rocker is reduced; the working pressure increases at the same rate as the displacement is reduced and it will not exceed the drive power ($p_B \cdot V_g = \text{constant}$).

The hydraulic output power (LR characteristic) is influenced by the pump efficiency.

Describe in plain text in turn:

-drive power P(kW)

-drive speed n(rpm)

- maximum flow $q_{v \text{ max}}$ (L/min)

A power diagram is generated based on detailed requirements.

Characteristic Curve

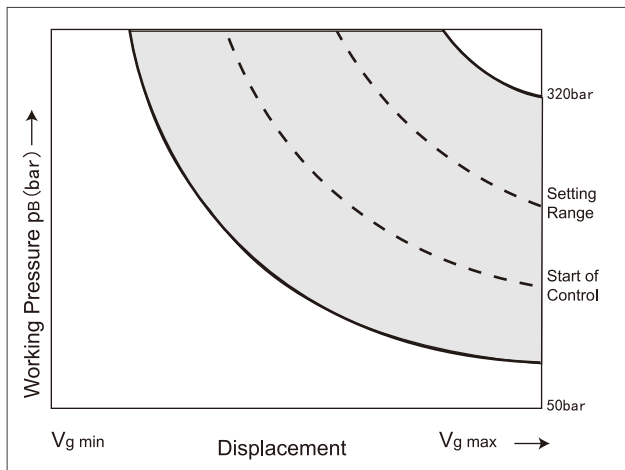

Circuit diagram

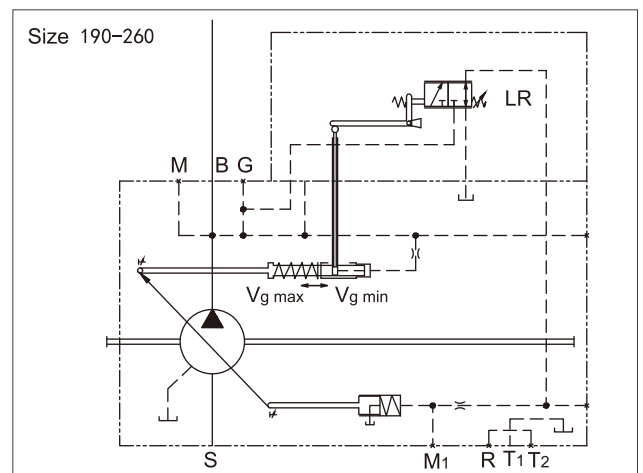
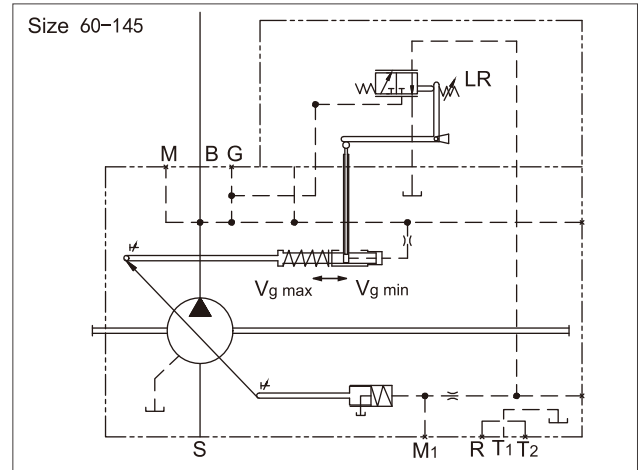

➤ **LR-Power Control**

LRD power controller with power cut-off

When it reaches the pressure setting, the pressure cut-off corresponds to the pressure controller that sets pump displacement back to $V_{g \text{ min}}$. It realizes override control of power controller. Namely, the power function is valid when it is below the preset pressure. The pressure cut-off function is integrated in the pump control module and preset as required before leaving the factory. Setting range from 50 to 350 bar

Characteristic Curve

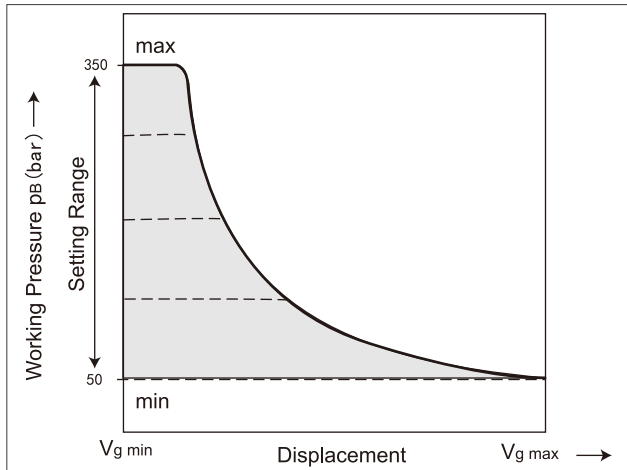

Circuit diagram

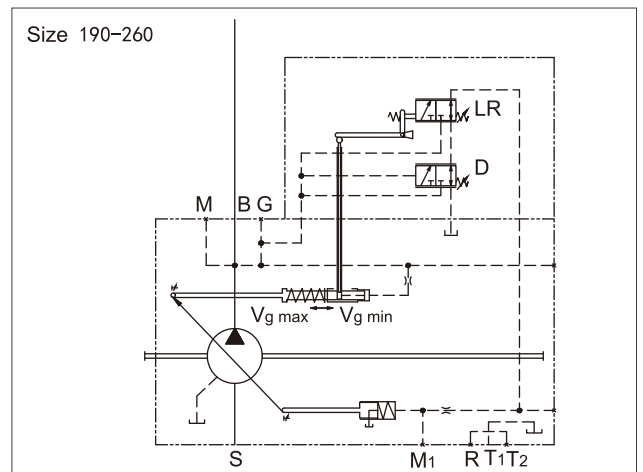
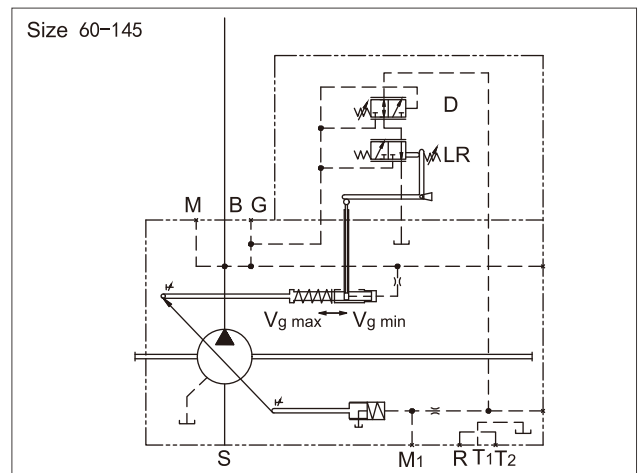

➤ LR-Power Control

LRDS power controller with power cut-off and load sensing

The load sensing controller works as a load-pressure controlled flow controller and adjusts the displacement of the pump to the flow required by the actuator.

The flow depends on the cross section of the external metering orifice (1) which is located between the pump outlet and the actuator. The flow is independent of the load pressure below the setting of the power curve and power cut-off and within the control range of the pump.

The metering orifice is usually a separately located load sensing directional valve (control block). The spool position of the directional valve determines the opening cross section of the metering orifice and thus the flow of the pump.

The load sensing controller compares the pressures upstream and downstream of the metering orifice and keeps the pressure drop (differential pressure Δp) through the orifice and thus the flow constant.

If the differential pressure Δp at the metering orifice increases, the pump swivels back (toward $V_{g \min}$). If the differential pressure Δp falls, the pump swivels out (toward $V_{g \max}$) until equilibrium at the metering orifice is restored.

$$\Delta p_{\text{hole}} = p_{\text{pump}} - p_{\text{actuator}}$$

Setting range of 14bar to 25bar

Setting of standard differential pressure: 18 bar. (Please specify in plain text when ordering.)

The standby pressure in zero stroke operation (metering orifice closed) is slightly higher than Δp setting.

(1) The metering orifice (control block) is not included in the scope of supply of pumps.

Characteristic Curve

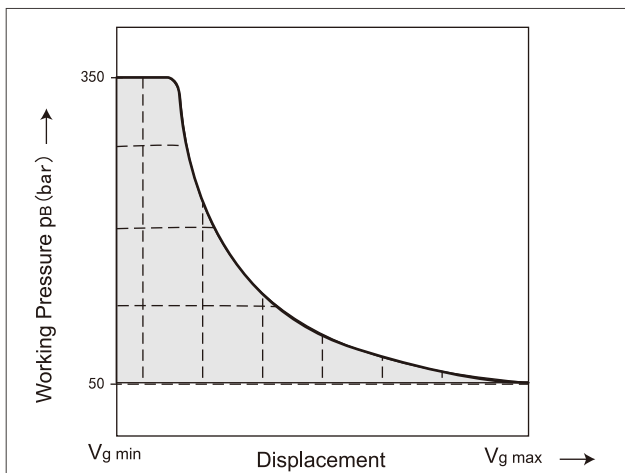

Circuit diagram

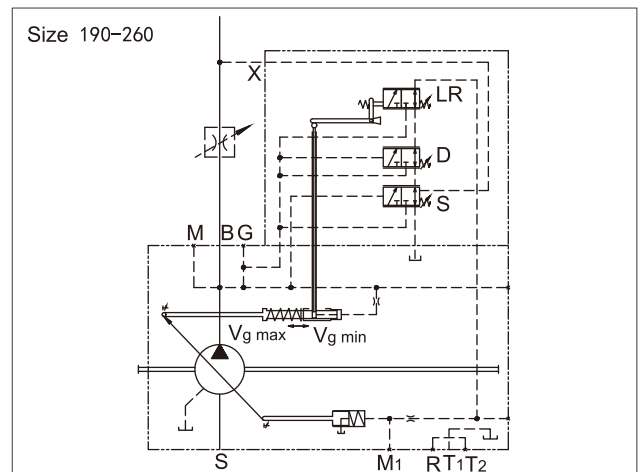
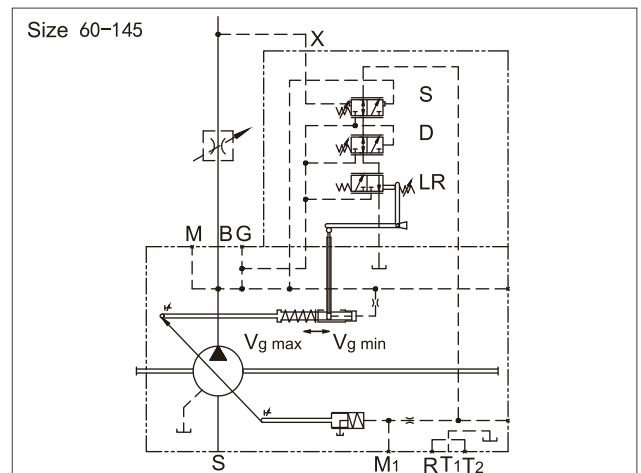

➤ **LR-Power Control**

LRU1/2 Electrical proportional displacement control

Control from $V_{g \min}$ to $V_{g \max}$
 The pump increases its displacement with increasing control current.

Technical Data-Solenoid

		LRU1	LRU2
Voltage		12V ($\pm 20\%$)	24V ($\pm 20\%$)
Control current	Start	400mA	200mA
	End	1200mA	600mA
Current limit		1.54A	0.77A
Nominal resistance(20°C)		5.5Ω	22.7Ω
Dither frequency		100Hz	
Duty cycle		100%	

Start position with control signal (control current):
 - $V_{g \max}$ at working pressure and external control pressure < 30 bar
 - $V_{g \min}$ at working pressure or external control pressure > 30 bar
 The electronic controller and amplifier as shown below are provided to activate the proportional solenoid.

Characteristic Curve

Increase in pilot pressure($V_{g \min}$ - $V_{g \max}$) $\Delta p=25\text{bar}$

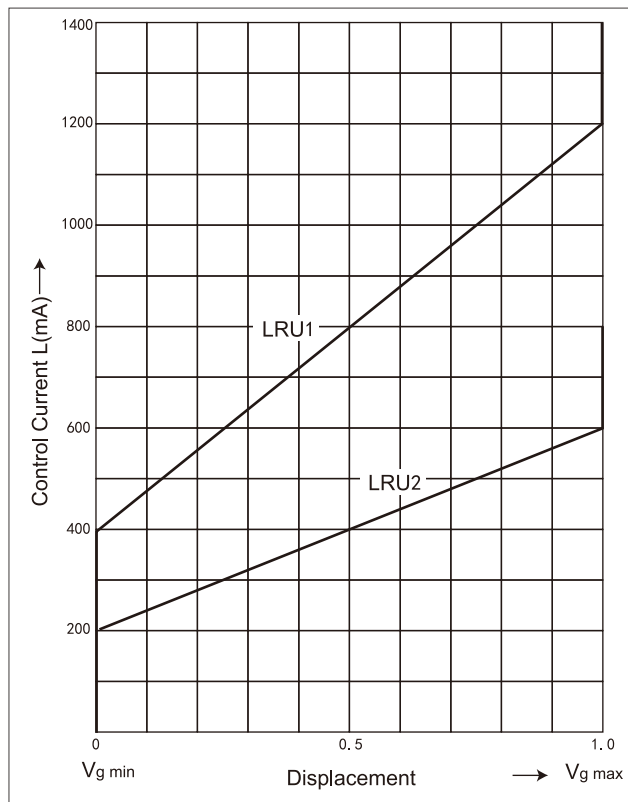

Circuit diagram

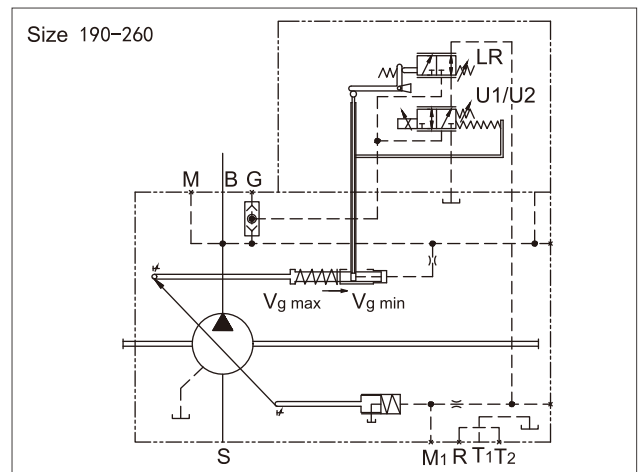
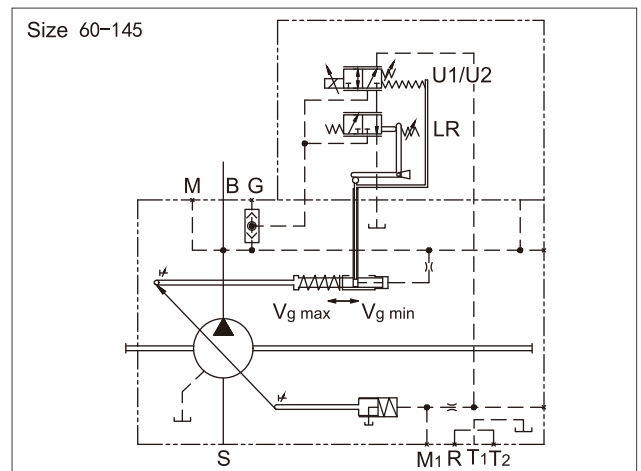

> LR-Power Control

LRH2/6 Hydraulic proportional displacement control

Control from $V_{g \min}$ to $V_{g \max}$
 The pump increases its displacement with increasing pilot pressure.
 Setting of beginning of control (at $V_{g \min}$): 4-10bar
 Specify in plain text the beginning of control.
 Start position without control signal (pilot pressure):
 - $V_{g \max}$ at working pressure and external control pressure < 30 bar
 - $V_{g \min}$ at working pressure and external control pressure > 30 bar

Characteristic Curve-H2

Increase in pilot pressure($V_{g \min}$ - $V_{g \max}$) $\Delta p=25\text{bar}$

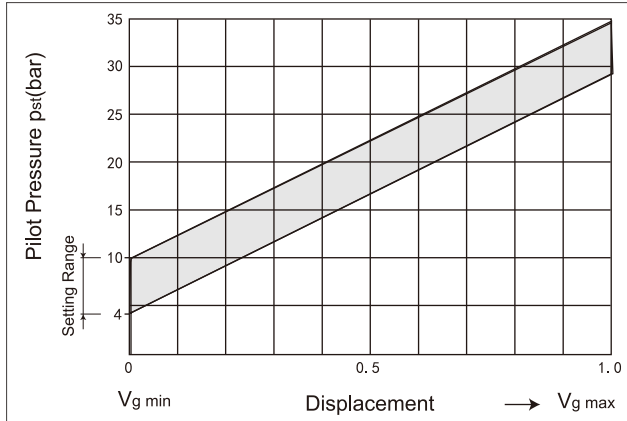

Characteristic Curve-H6

Increase in pilot pressure($V_{g \min}$ - $V_{g \max}$) $\Delta p=10\text{bar}$

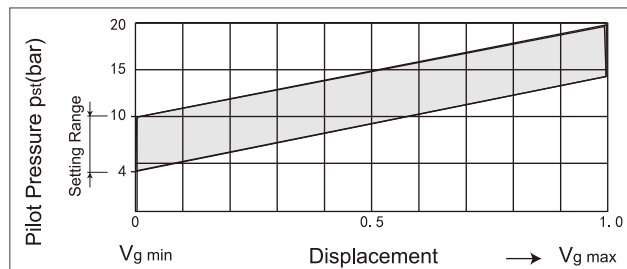

Circuit diagram

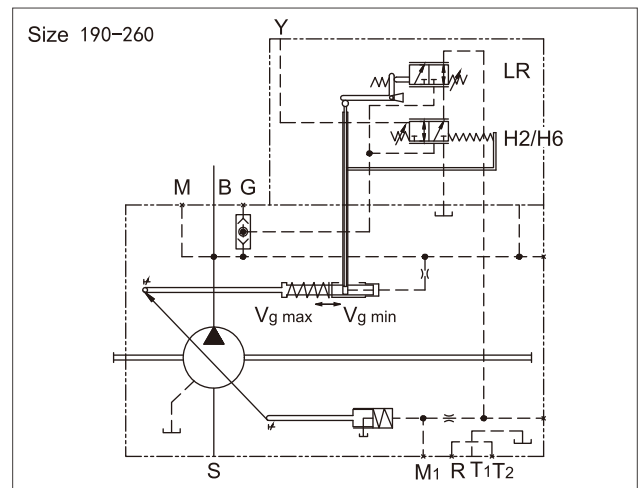
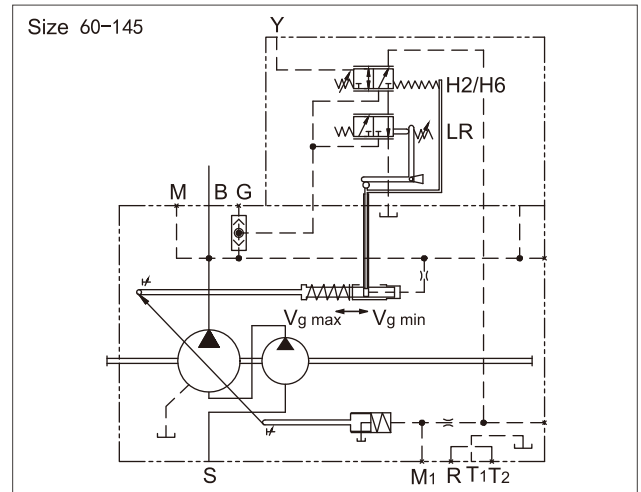

➤ LR-Power Control

LG1 Pilot pressure negative proportional power control

Override control of control settings is realized with external pilot pressure signals. The pilot pressure acts on the adjusting spring for mechanical power control via port Z.

The mechanical power may be regulated by changing the pilot pressure. If the pilot pressure signal is adjusted by load limit control, the power consumption of all actuators will reduce to match the power supplied by the engine.

The pilot pressure for power control is supplied by an external control element.

Increase in pilot pressure will reduce power setting.

Characteristic Curve

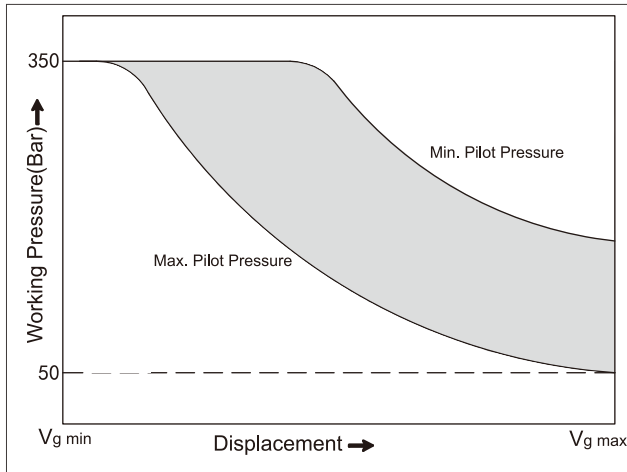

Circuit diagram

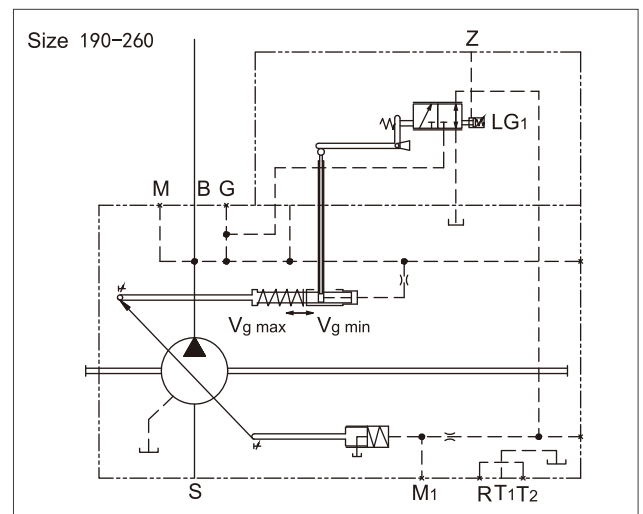
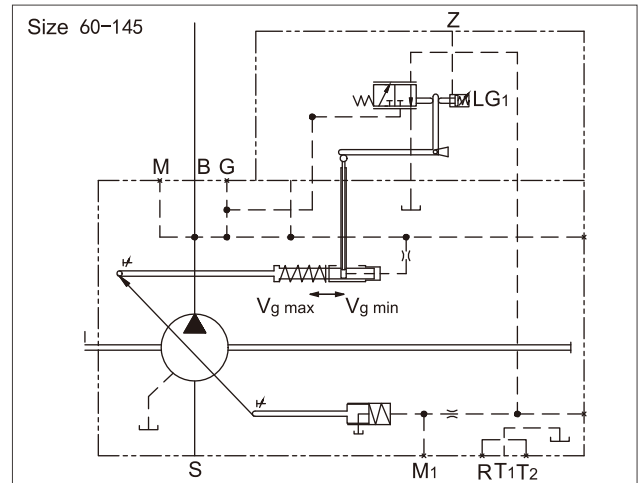

➤ LR-Power Control

LE1/2 Electrical negative proportional power control

Contrary to hydraulic power control - override control, the basic power setting can be reduced by the electronic pilot current acting on the proportional solenoid. The force thus incurred acts on the adjusting spring for mechanical power control.

The mechanically adjusted basic power setting can be varied via different control current settings.

Increased current = reduced power

If the pilot current signal is adjusted by load limit control, the power consumption of all actuators will reduce to match the power supplied by the diesel engine.

12V(LE1) or 24V(LE2) power supply is required for controlling proportional solenoids.

Technical Data-Solenoid

		LE1	LE2
Voltage		12V (±20%)	24V (±20%)
Control current	Start	400mA	200mA
	End	1200mA	600mA
Current limit		1.5A	0.77A
Nominal resistance(20°C)		5.5Ω	22.7Ω
Dither frequency		100Hz	
Duty cycle		100%	

Characteristic Curve

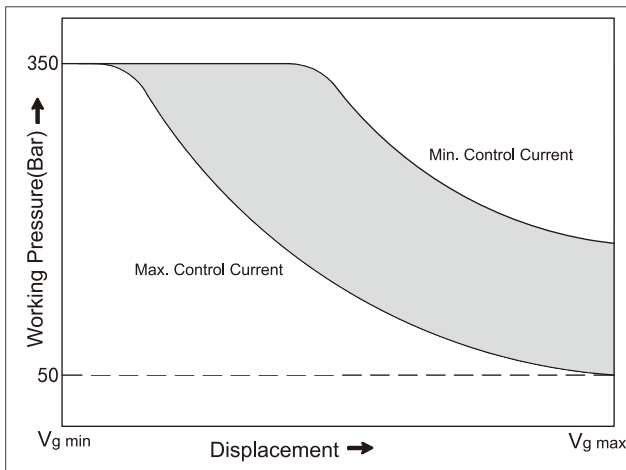

Circuit diagram

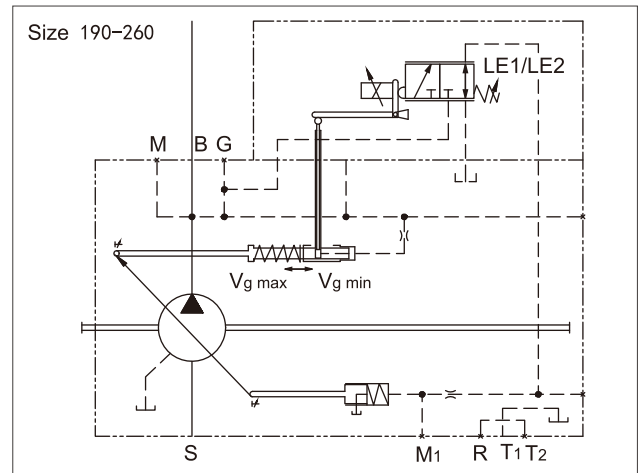
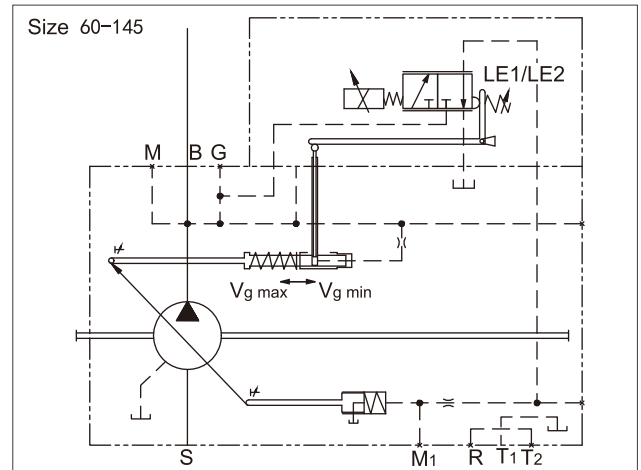

➤ **EP-Electric Controller with Proportional Solenoid**

EP1/2 Electrical proportional displacement control

Control from $V_{g \text{ min}}$ to $V_{g \text{ max}}$

The pump increases its displacement with increasing control current.

Start position without control signal (control current):

- $V_{g \text{ max}}$ at working pressure and external control pressure < 30 bar

- $V_{g \text{ min}}$ at working pressure and external control pressure > 30 bar

30 bar control pressure is required for the pump to move from its initial position $V_{g \text{ max}}$ to $V_{g \text{ min}}$.

The required control pressure comes from the load pressure or external control pressure at port G.

An external control pressure of approx. 30 bar is required at port G to ensure control even at low working pressure (< 30 bar).

Note:

Remove the shuttle valve if no external control pressure is connected to port G.

Install a pump with EP controller in the reservoir only when the hydraulic fluid of mineral oils is used and the reservoir temperature is up to 80 °C.

Technical Data-Solenoid

		EP1	EP2
Voltage		12V ($\pm 20\%$)	24V ($\pm 20\%$)
Control current	Start	400mA	200mA
	End	1200mA	600mA
Current limit		1.54A	0.77A
Nominal resistance(20°C)		5.5Ω	22.7Ω
Dither frequency		100Hz	
Duty cycle		100%	

Circuit diagram

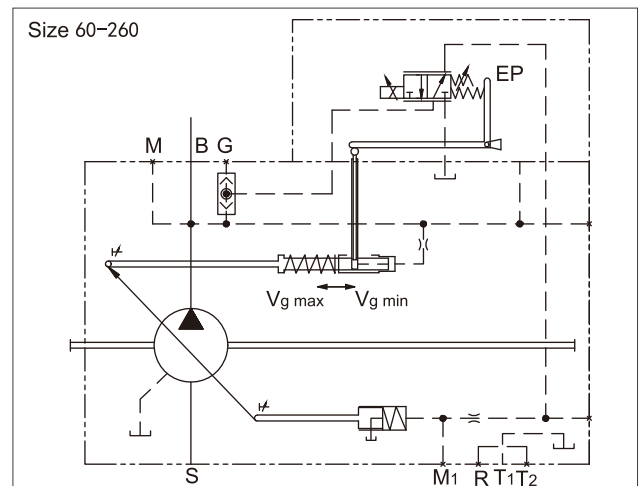

Characteristic Curve

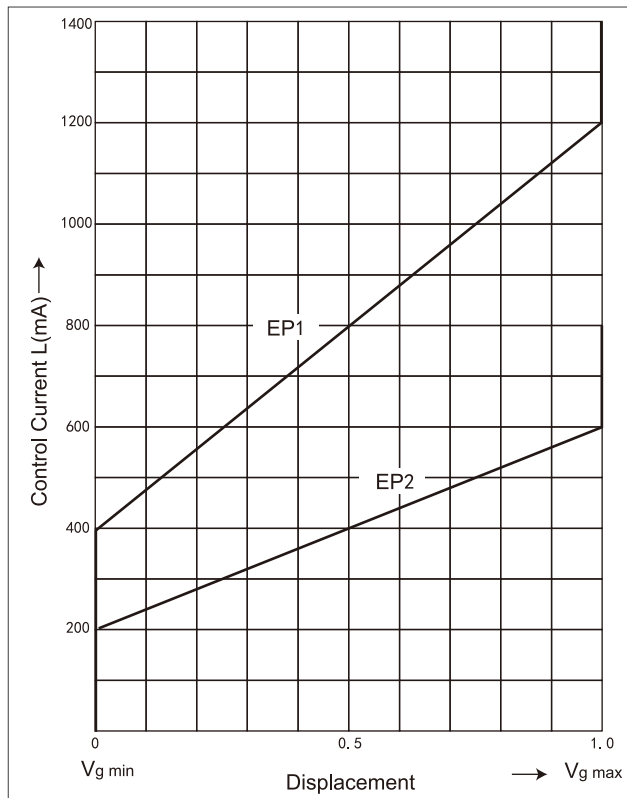

➤ EP-Electric Controller with Proportional Solenoid

EP.D Electric controller with pressure cut-off

When it reaches the pressure setting, the pressure cut-off corresponds to the pressure controller that sets pump displacement back to $V_g \text{ min}$. It realizes override control of EP controller. Namely, the displacement control dependent control current functions below the set pressure. The pressure cut-off valve is integrated in the control casing and set to the fixed pressure value before leaving the factory. Setting range from 50 to 350bar

Characteristic Curve-pressure cut-off, , D

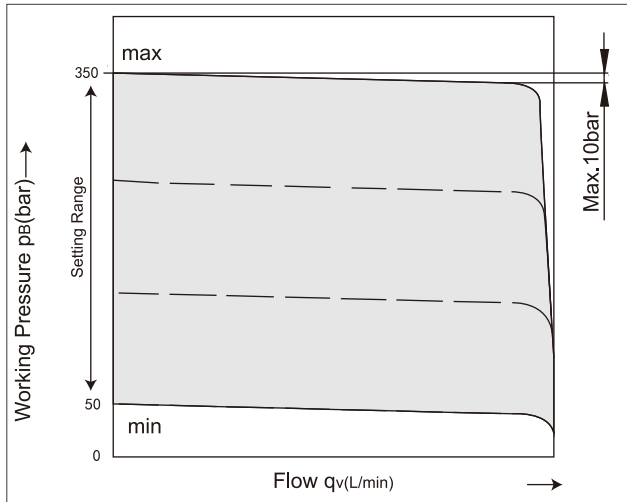

Circuit diagram

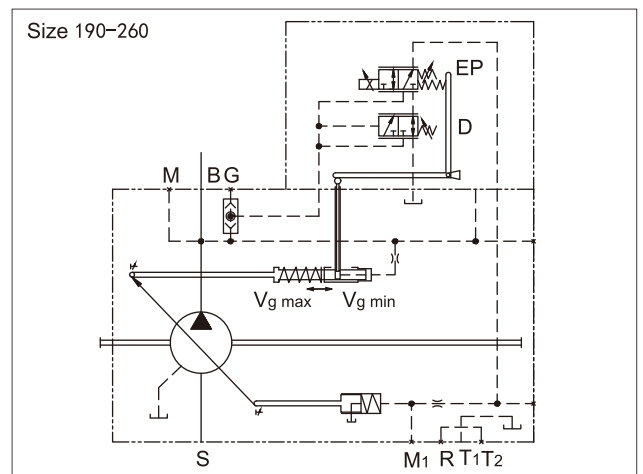
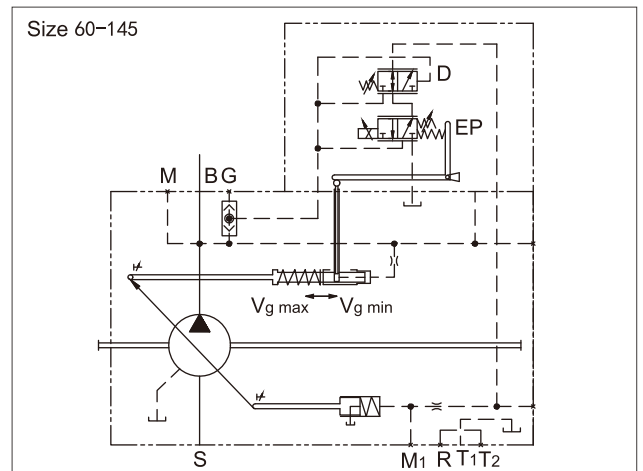

► Installation Dimensions

Size 60
N00, LRDS control
Without charge pump

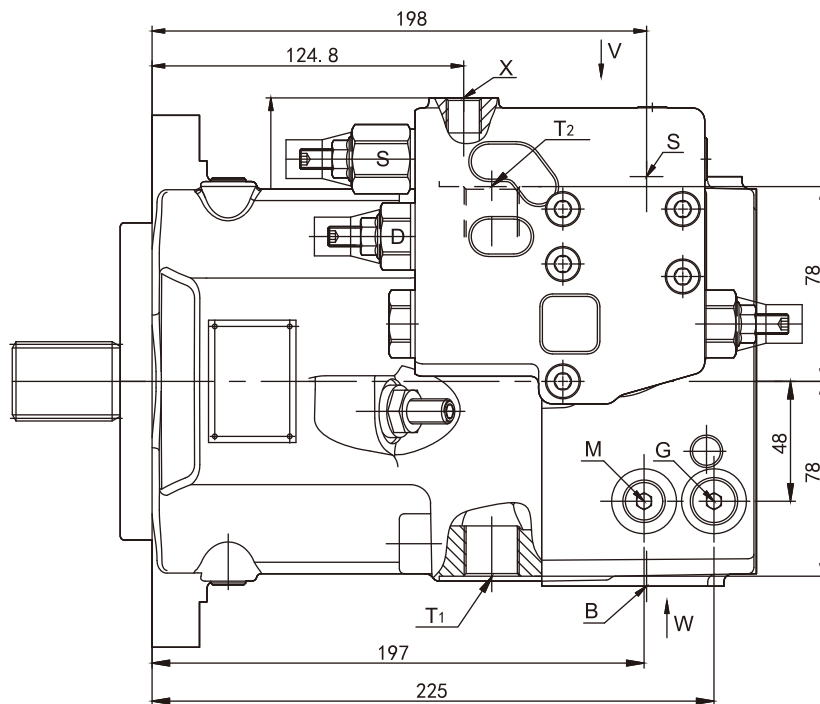
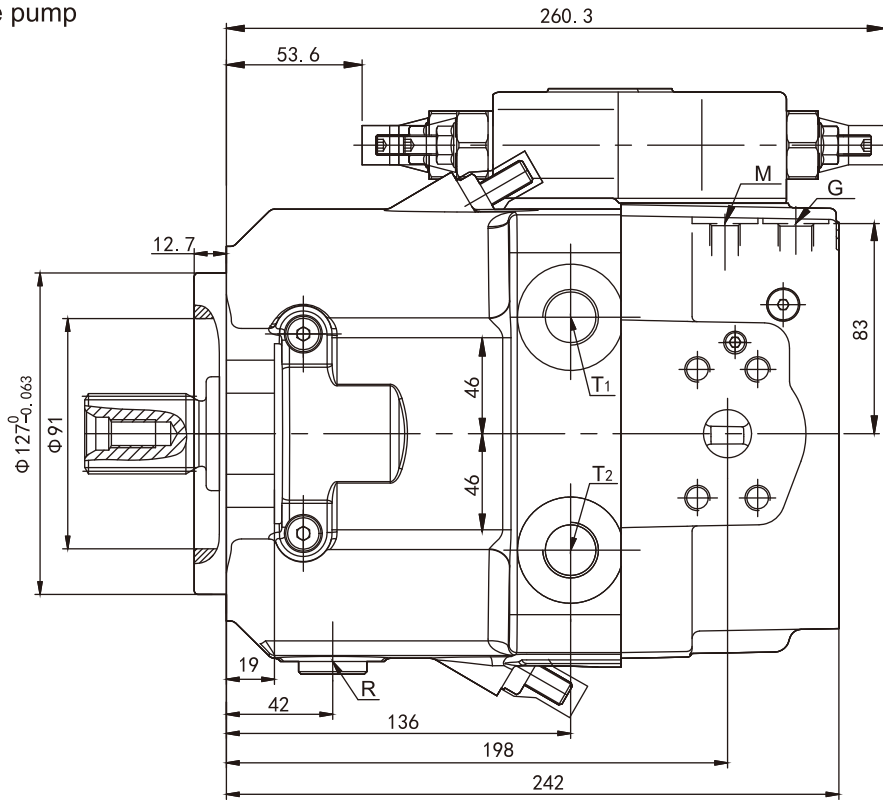

► Installation Dimensions

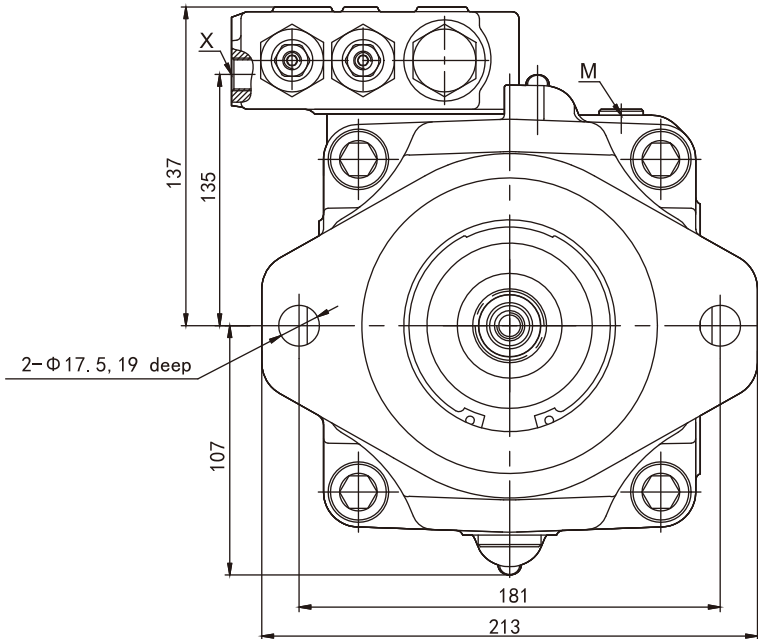

Detail W

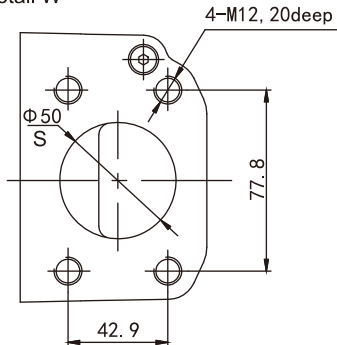

Detail V

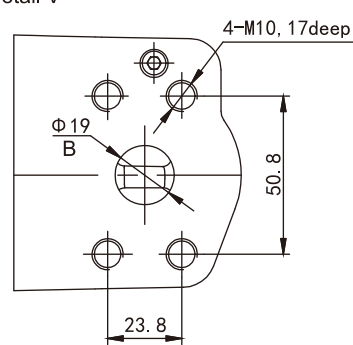

Ports SAE J518		
B	Working port (high pressure series)	3/4"
	Fastening thread	M10,17deep
S	Suction port (standard)	2"
	Fastening thread	M12,20deep
T1/T2	Case drain port	M22x1.5,14deep

R	Drain port/Air bleed port	M22x1.5,14deep
M1	Pressure measuring position, positioning chamber	M12x1.5,12deep
M	Pressure measuring position, working port	M12x1.5,12deep
X	Pilot pressure port	M14x1.5,12deep

Parallel keyed shaft P
DIN 6885-AS10x8x56

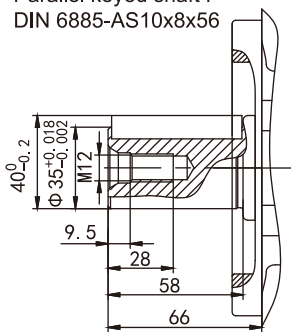

Splined shaft S²⁾
ANSI B92.1a 30°
1-1/4" 14T 12/24DP

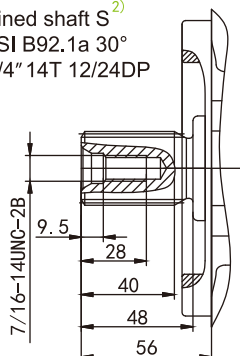

Splined shaft Z¹⁾
DIN 5480
W35x2x30x16x9g

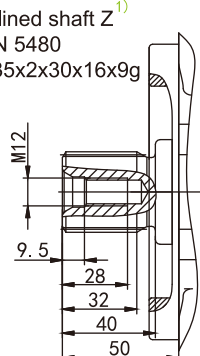

Splined shaft T²⁾
ANSI B92.1a 30°
1-3/8" 21T 16/32DP

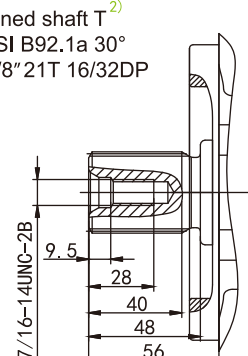

1): DIN 5480-2006, 30° pressure angle, flat root, side fit, tolerance class 9g
2): ANSI B92.1a-1976, 30° pressure angle, flat root, side fit, tolerance class 6

> Installation Dimensions

LRDU1/2 power control

With pressure cut-off and electronic control variable displacement

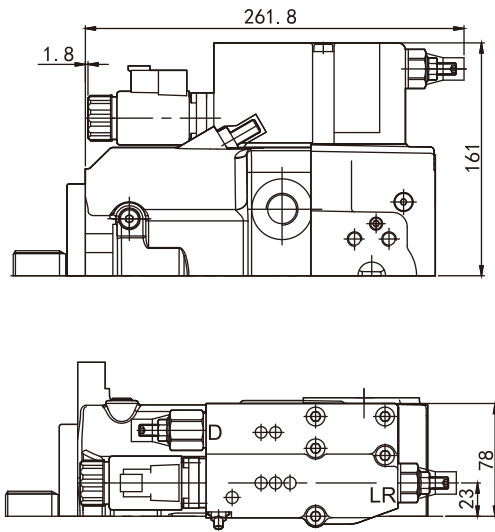

DRS pressure controller

With load sensitive control

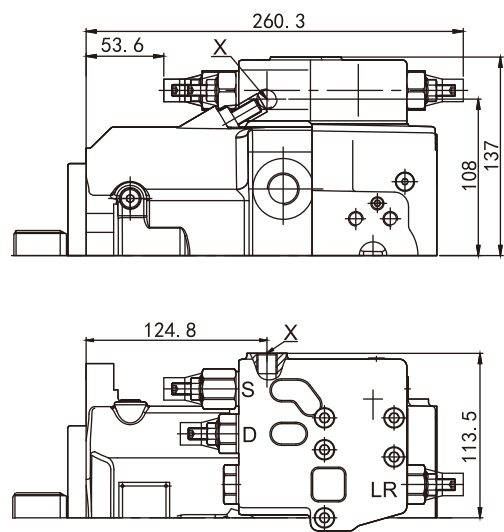

Pilot control port X: M14x1.5, 12deep

➤ Installation Dimensions

Size 95/115/125
N00, LRDS control

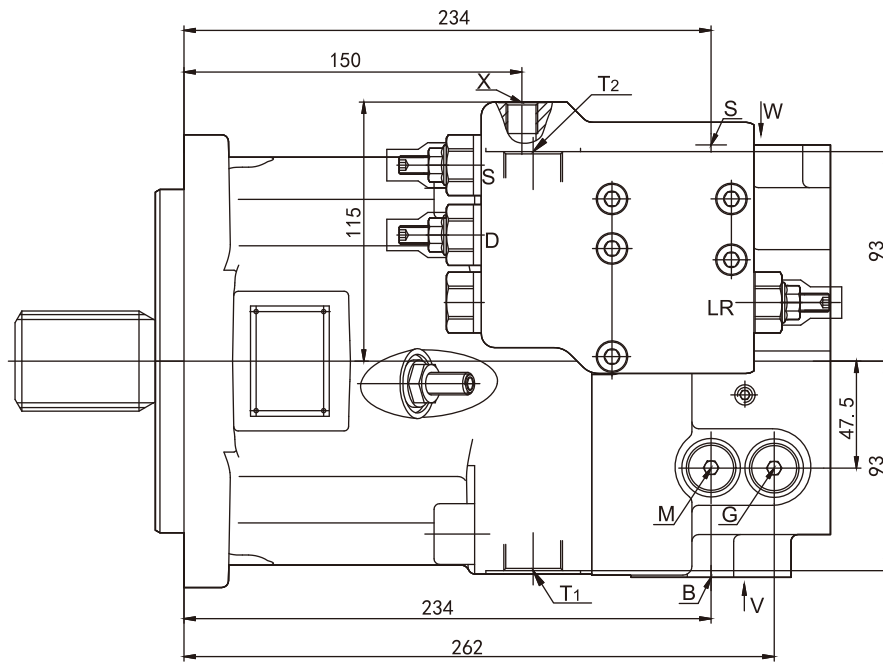
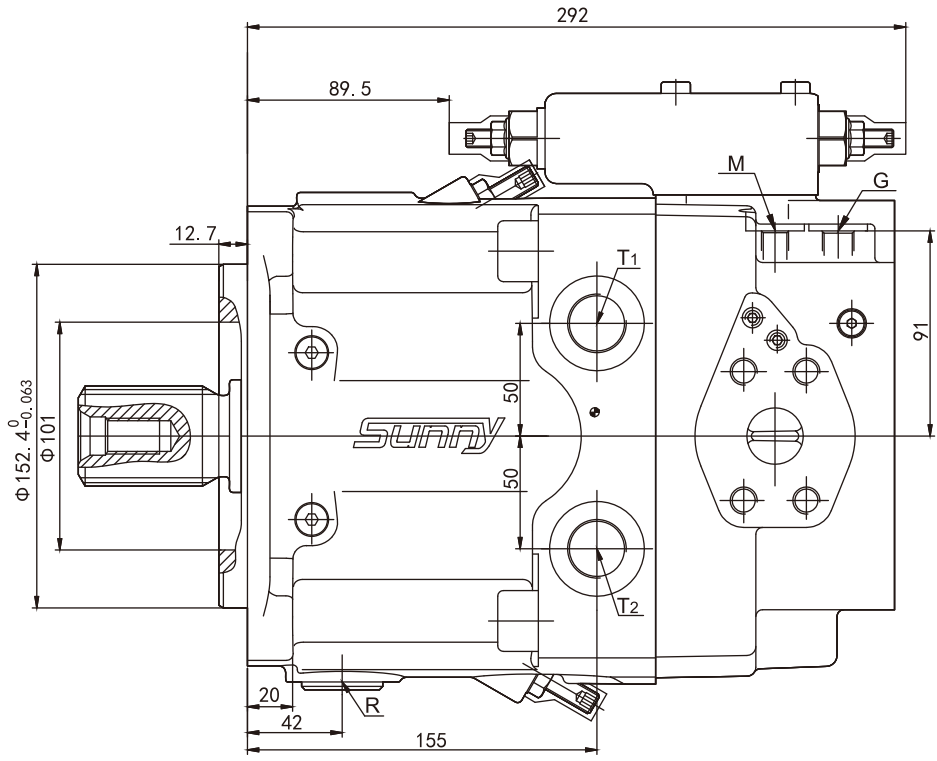

► Installation Dimensions

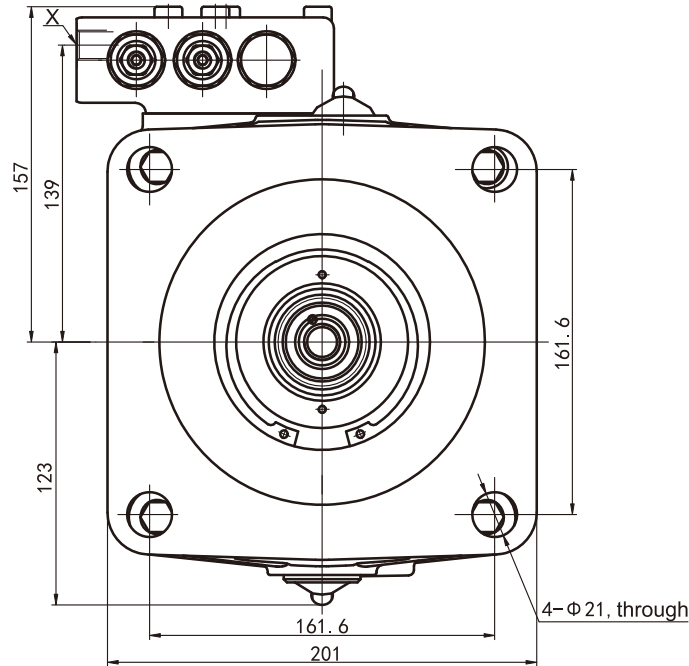

Without charge pump

Detail W

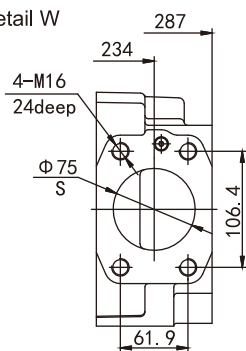

Detail V

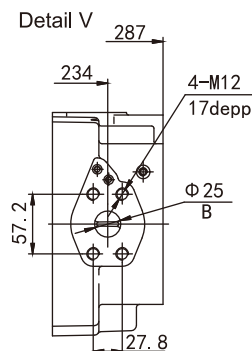

With charge pump

Detail W

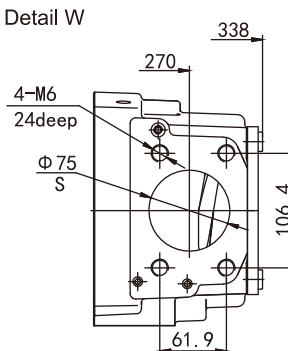

Detail V

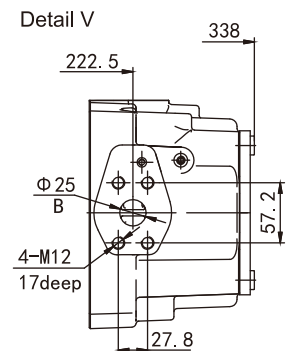

Ports SAE J518		
B	Working port (high pressure series)	1"
	Fastening thread	M10,17deep
S	Suction port (standard)	3"
	Fastening thread	M16,17deep
T1/T2	Case drain port	M26x1.5,16deep

R	Drain port/Air bleed port	M26x1.5,16deep
M1	Pressure measuring position, positioning chamber	M12x1.5,12deep
M	Pressure measuring position, working port	M12x1.5,12deep
X	Pilot pressure port	M14x1.5,12deep

Parallel keyed shaft P
DIN 6885-AS14x9x80

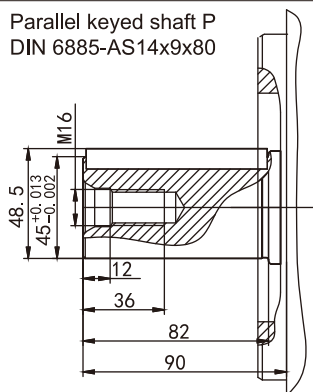

Splined shaft S ²⁾
ANSI B92.1a 30°
1-3/4" 13T 8/16DP

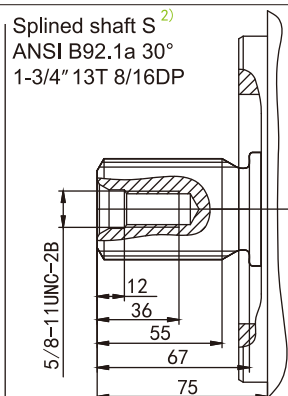

Splined shaft Z ¹⁾
DIN 5480
W45x2x30x21x9g

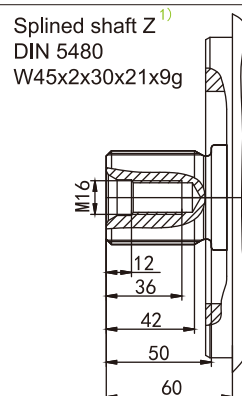

Splined shaft U ²⁾
ANSI B92.1a 30°
1-1/2" 17T 12/24DP

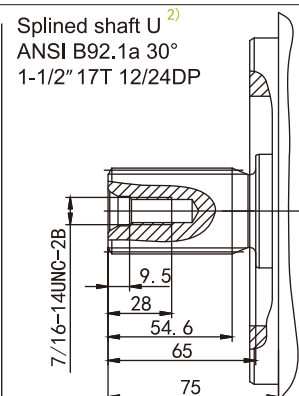

1): DIN 5480-2006, 30° pressure angle, flat root, side fit, tolerance class 9g

2): ANSI B92.1a-1976, 30° pressure angle, flat root, side fit, tolerance class 6

➤ Installation Dimensions

LRDH2/6 power control

With pressure cut-off and hydraulic control variable displacement

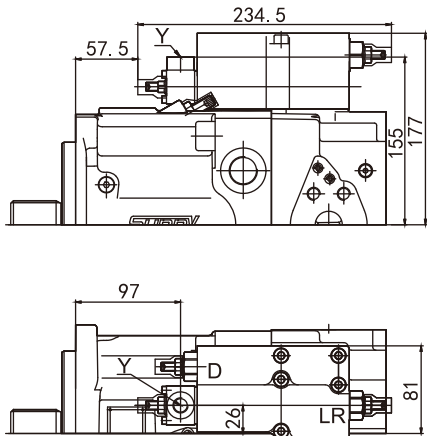

External control port G: M14x1.5,12deep(see connection dimensions diagram for its position; plugged before delivery)
Pilot pressure port Y: M14x1.5,12deep

LRDU1/2 power control

With pressure cut-off and electronic control variable displacement

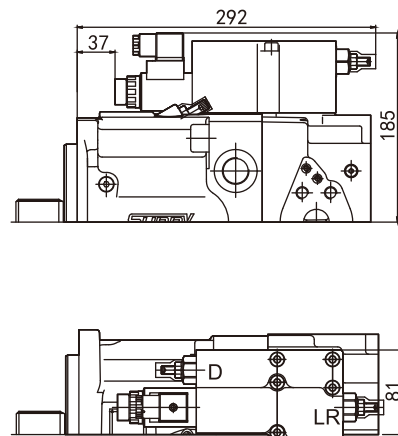

External control port G: M14x1.5,12deep(see connection dimensions diagram for its position; plugged before delivery)

DRS pressure control

With load sensitive control

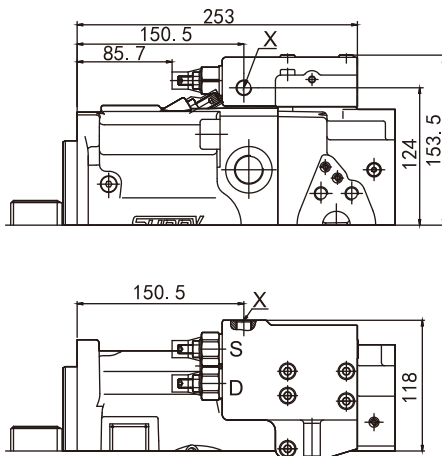

Pilot control port X: M14x1.5,12deep

LRDS constant power control

With pressure control and load sensitive control

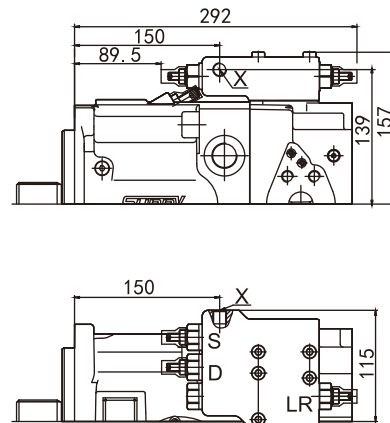

Pilot control port X: M14x1.5,12deep

> Installation Dimensions

LE2S2 power control with electric override
With load sensing control, override

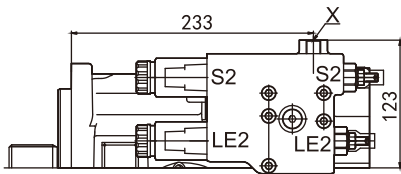
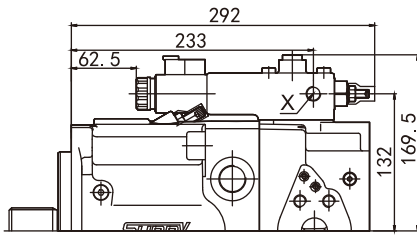

Pilot control port X: M14x1.5, 12deep

EP1D/2D electronic control
Electronic control variable displacement and power cut-off

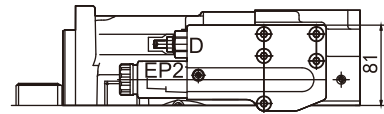
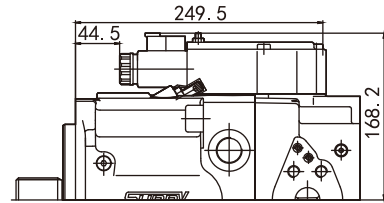

External control port G: M14x1.5, 12deep (see connection dimensions diagram for its position; plugged before delivery)

LE2S constant power control with electric override
With load sensitive control

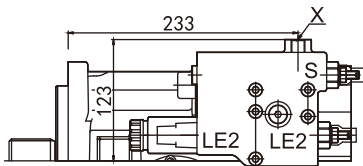
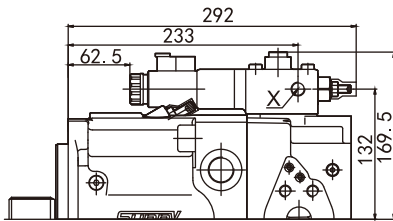

Pilot control port X: M14x1.5, 12deep

➤ Installation Dimensions

Size 130/145/165
N00, LRDS control

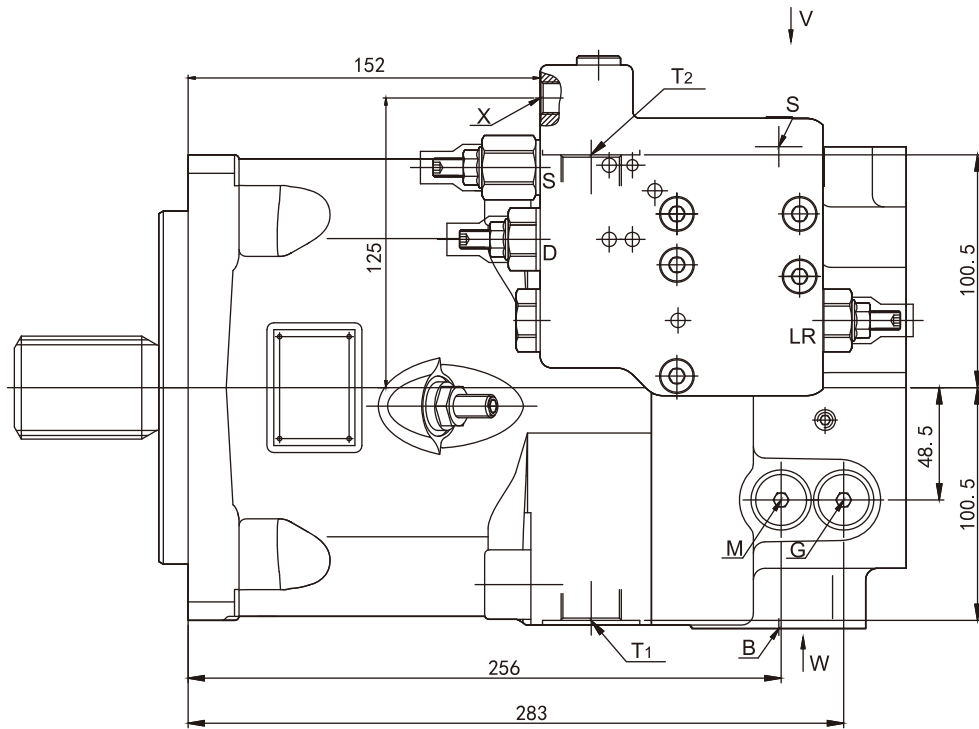
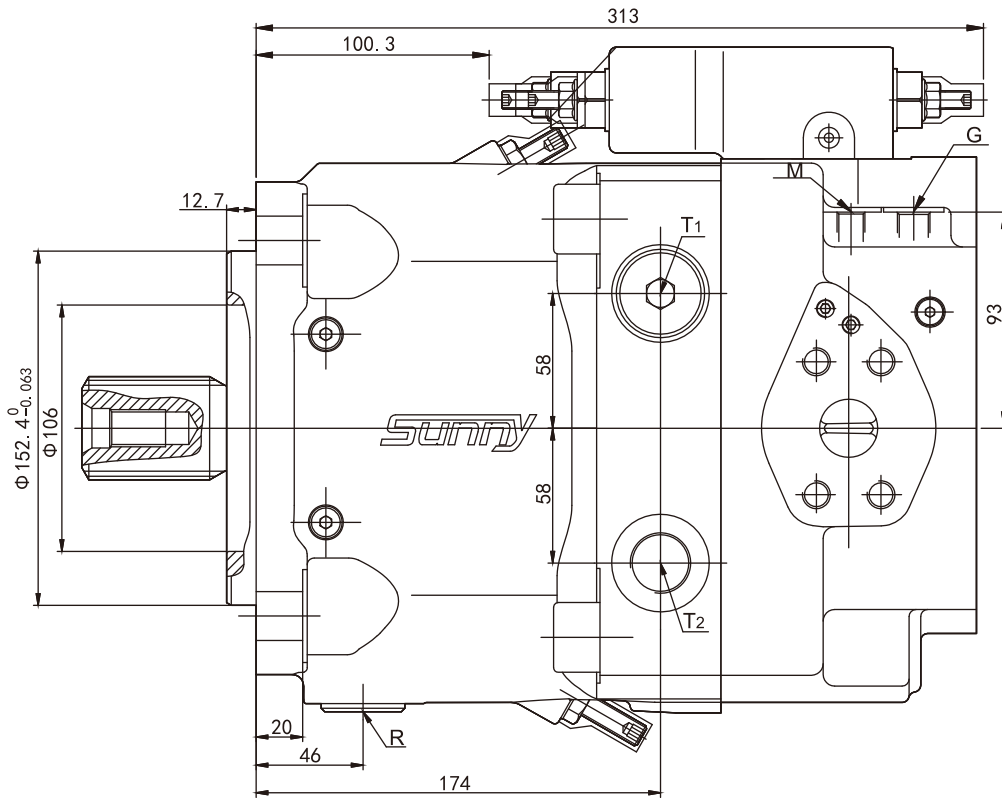

► Installation Dimensions

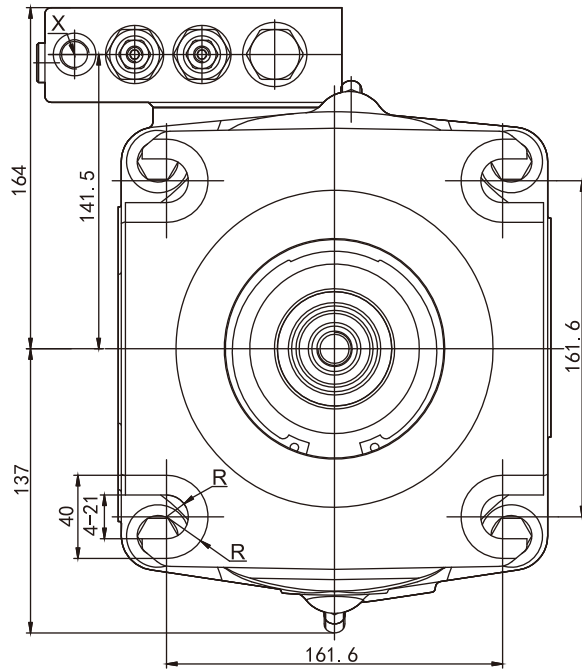

Without charge pump
Detail W

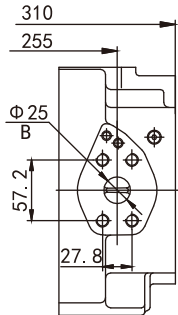

Detail V

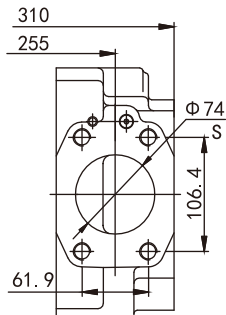

With charge pump
Detail W

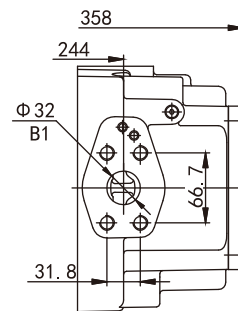

Detail V

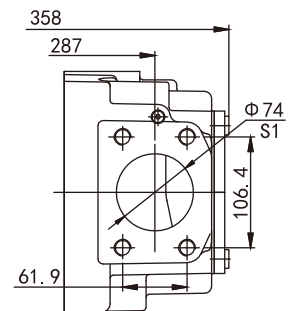

Ports SAE J518			T1/T2	Case drain port	M26x1.5, 16deep
B	Working port (high pressure series)	1"	R	Drain port/Air bleed port	M26x1.5, 16deep
	Fastening thread	M12x1.75, 17deep	M1	Pressure measuring position, positioning chamber	M26x1.5, 16deep
B1	Working port (high pressure series)	1 1/4"	M	Pressure measuring position, working port	M12x1.5, 12deep
	Fastening thread	M14x1, 19deep	X	Pilot pressure port	M14x1.5, 12deep
S/S1	Suction port (standard)	3"			
	Fastening thread	M16, 17deep			

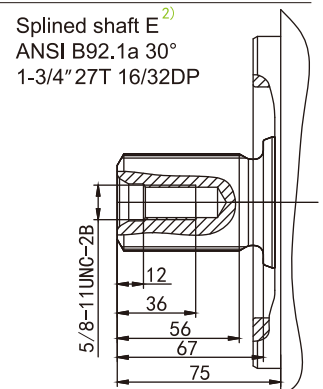
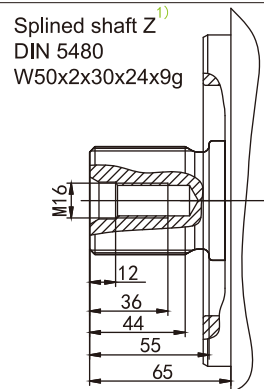
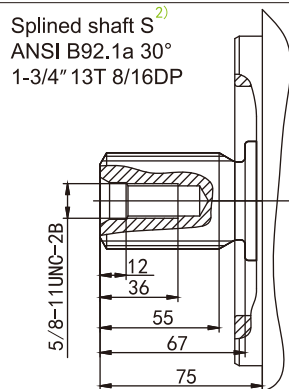
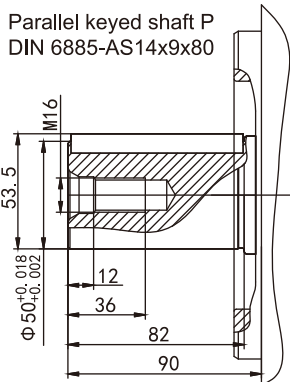

1): DIN 5480-2006, 30° pressure angle, flat root, side fit, tolerance class 9g

2): ANSI B92.1a-1976, 30° pressure angle, flat root, side fit, tolerance class 6

► Installation Dimensions

LRDH2/6 power control

With pressure cut-off and hydraulic control variable displacement

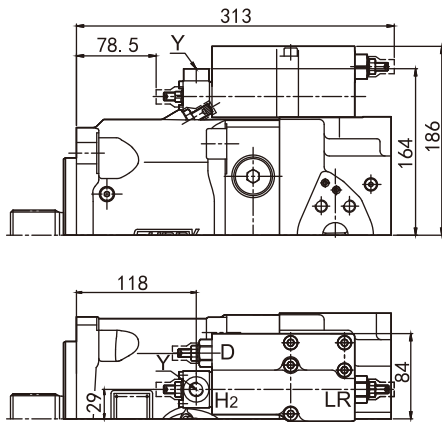

External control port G: M14x1.5,12deep(see connection dimensions diagram for its position; plugged before delivery)
Pilot pressure port Y: M14x1.5,12deep

LRDU1/2 power control

With pressure cut-off and electronic control variable displacement

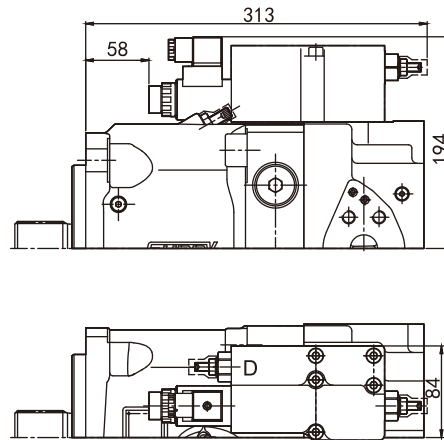

External control port G: M14x1.5,12deep(see connection dimensions diagram for its position; plugged before delivery)

DRS pressure control

With load sensitive control

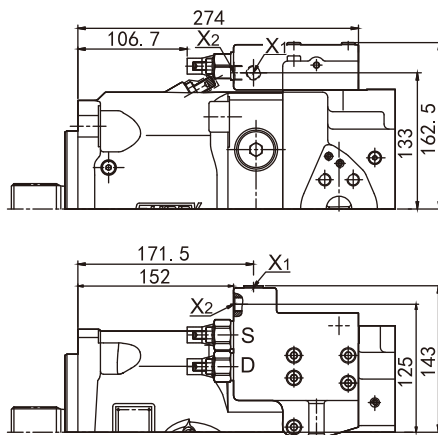

Pilot pressure port X1: M14x1.5,12deep(plugged before delivery)
Pilot pressure port X2: M14x1.5,12deep

LRDS constant power control

With pressure control and load sensitive control

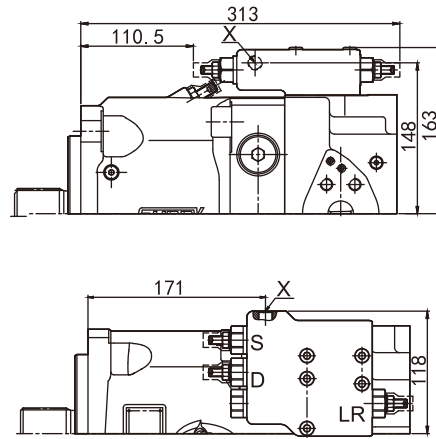

Pilot pressure port X: M14x1.5,12deep

LRS constant power control

With load sensitive control

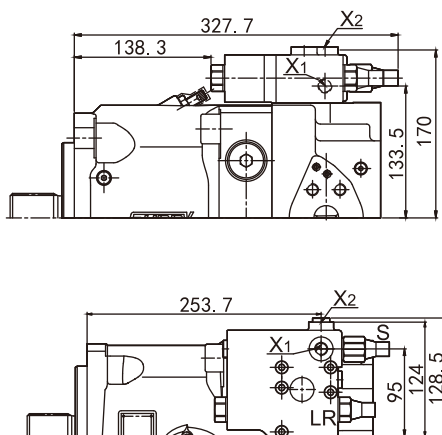

Pilot pressure port X1: M14x1.5,12deep(plugged before delivery)
Pilot pressure port X2: M14x1.5,12deep

EP1D/2D electronic control

Electronic control variable displacement and power cut-off

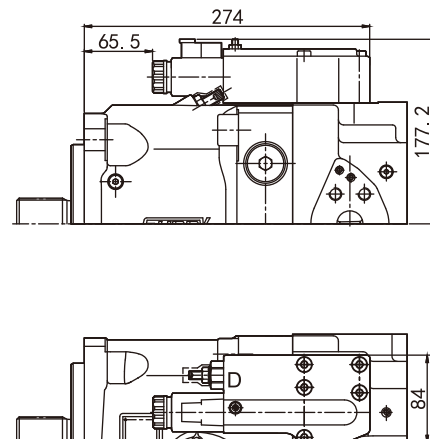

External control port G: M14x1.5,12deep(see connection dimensions diagram for its position; plugged before delivery)

> Installation Dimensions

LE2S2 power control with electric override
With load sensing control, override

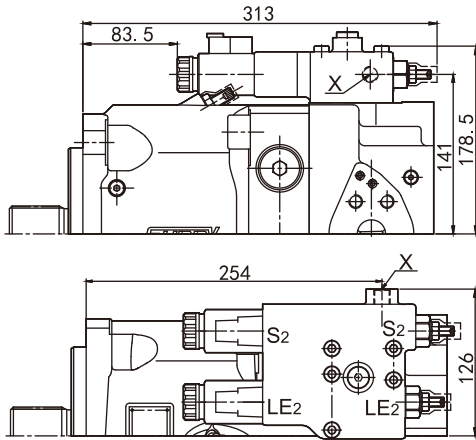

Pilot pressure port X: M14x1.5, 12deep

LE2S constant power control with electric override
With load sensitive control

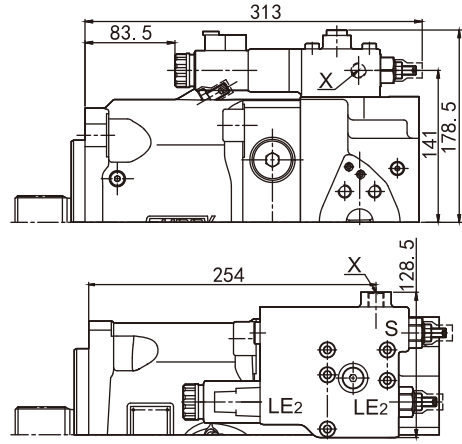

Pilot pressure port X: M14x1.5, 12deep

LE4DS constant power control with electric override
With pressure control and load sensitive control

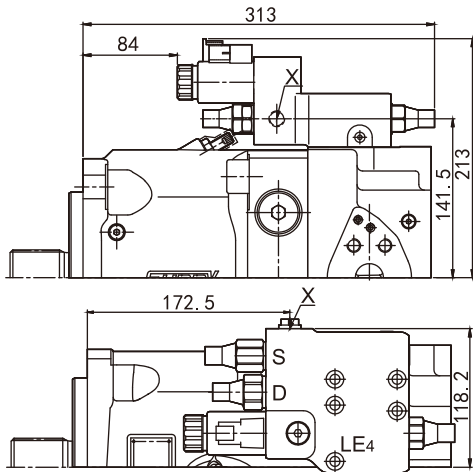

Pilot pressure port X: M14x1.5, 12deep

► Installation Dimensions

Size 190
 N00, LRDS control
 With charge pump

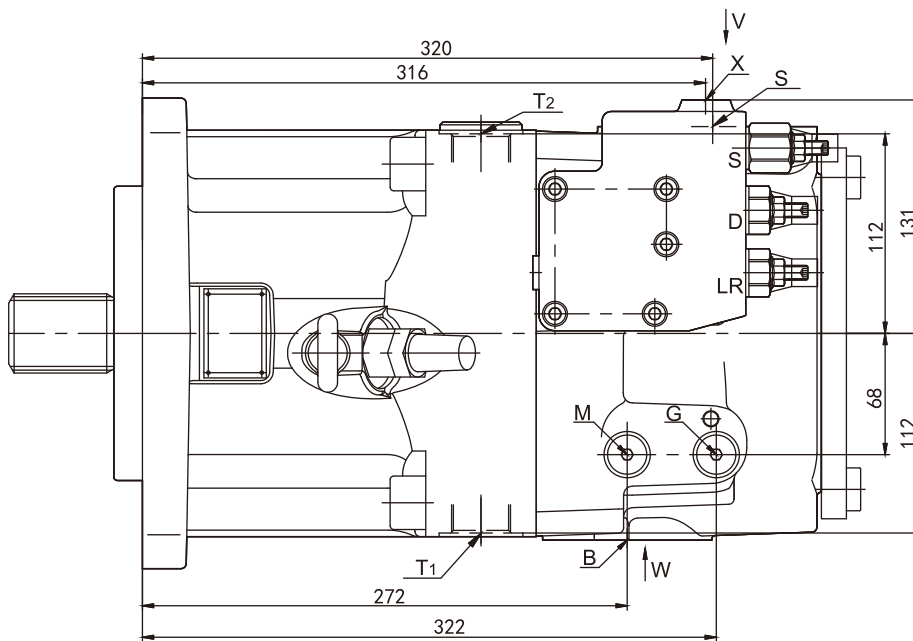
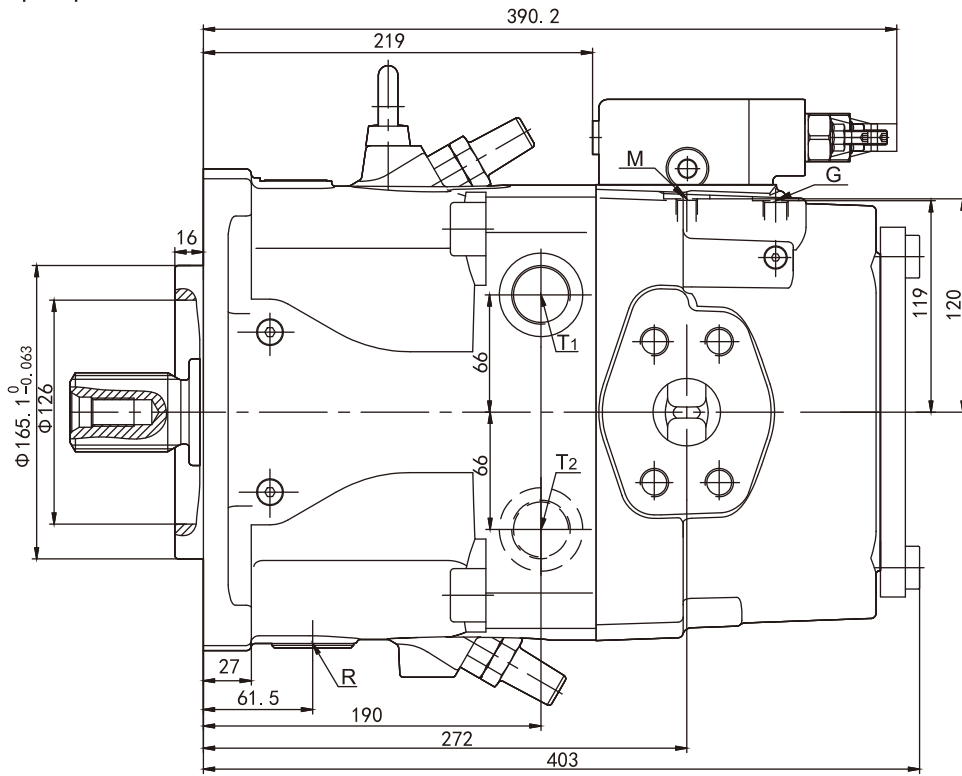

► Installation Dimensions

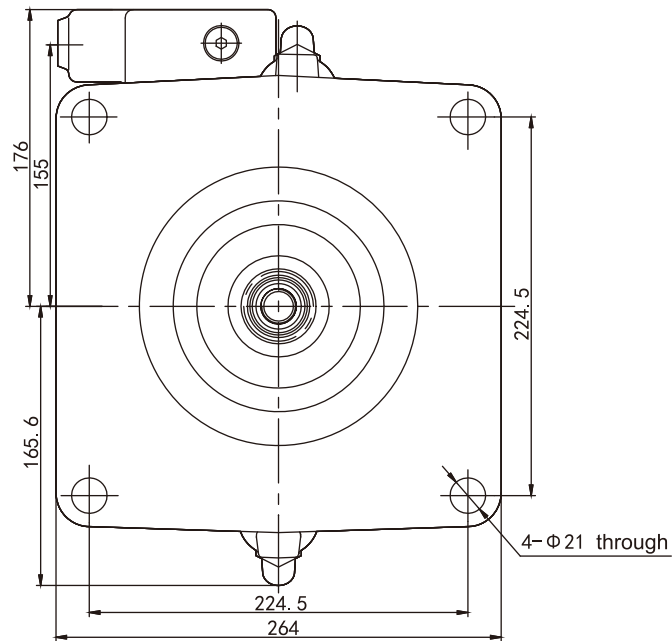

Detail W

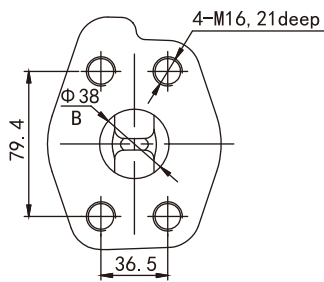

Detail V

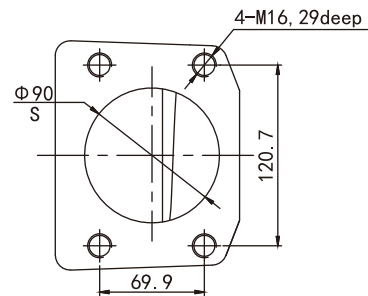

Ports SAE J518		
B	Working port (high pressure series)	1 1/2"
	Fastening thread	M16,21deep
S	Suction port (standard)	3 1/2"
	Fastening thread	M16,17deep
T1/T2	Case drain port	M33x2,16deep

R	Drain port/Air bleed port	M33x2,16deep
M1	Pressure measuring position, positioning chamber	M12x1.5,12deep
M	Pressure measuring position, working port	M12x1.5,12deep
X	Pilot pressure port	M14x1.5,12deep

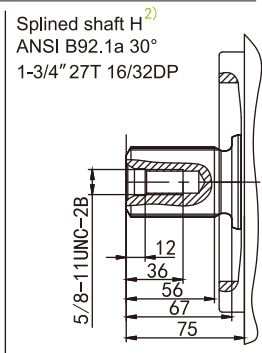
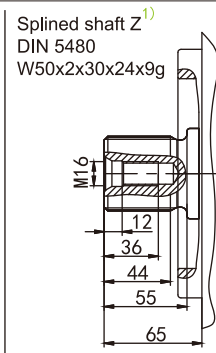
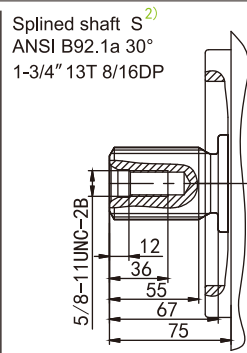
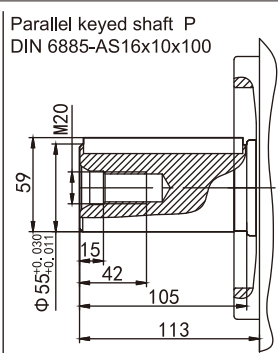
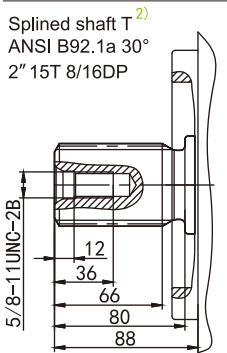

1): DIN 5480-2006, 30°pressure angle, flat root, side fit, tolerance class 9g
2): ANSI B92.1a-1976, 30°pressure angle, flat root, side fit, tolerance class 6

► Installation Dimensions

LRDH2/6 constant power

With pressure cut-off & hydraulic control variable displacement
(from: V_g min to V_g max)

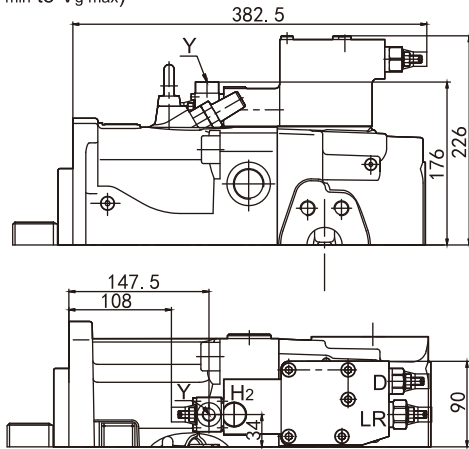

External control port G: M14x1.5,12deep(see connection dimensions diagram for its position; plugged before delivery)
Pilot pressure port : M14x1.5,12deep

LRDU1/2 constant power

With pressure cut-off & electronic control variable displacement
(from: V_g min to V_g max)

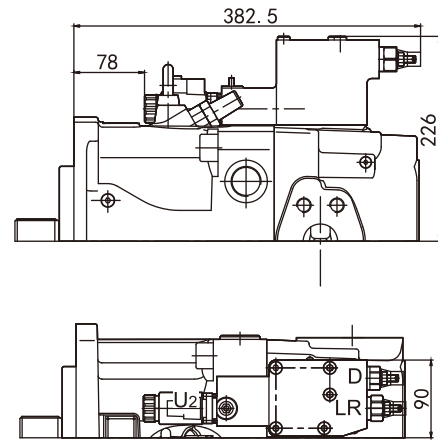

External control port G: M14x1.5,12deep(see connection dimensions diagram for its position; plugged before delivery)

DRS pressure control & load sensitive control

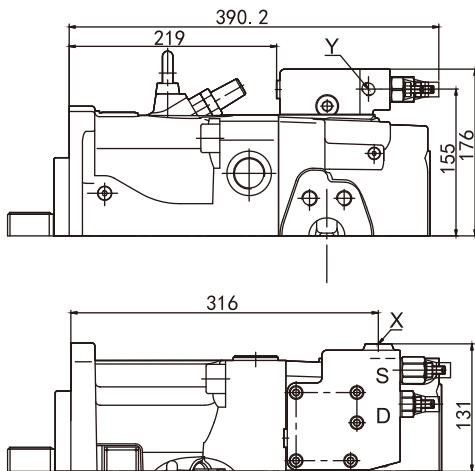

Pilot pressure port X: M14x1.5,12deep

LRDS constant power control

With pressure control and load sensitive control

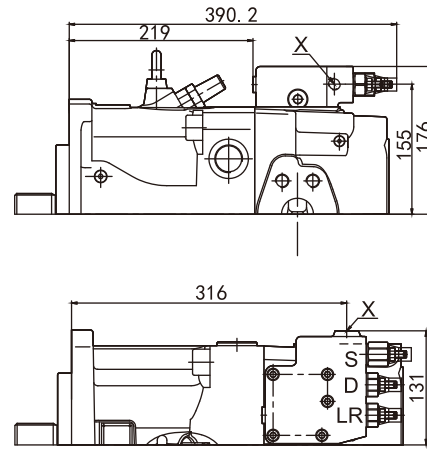

Pilot pressure port X: M14x1.5,12deep

LE2S2 constant power control with electric override
With load sensing control, override

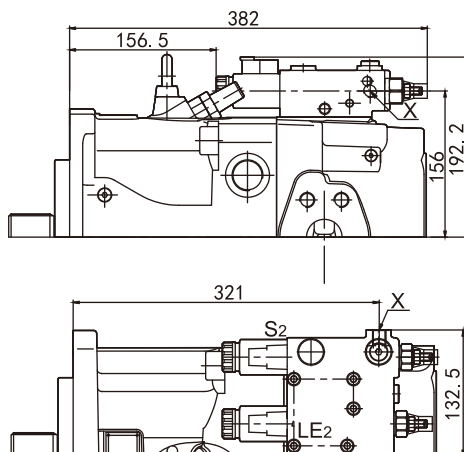

Pilot pressure port X: M14x1.5,12deep

EP2D with proportional solenoid & pressure cut-off

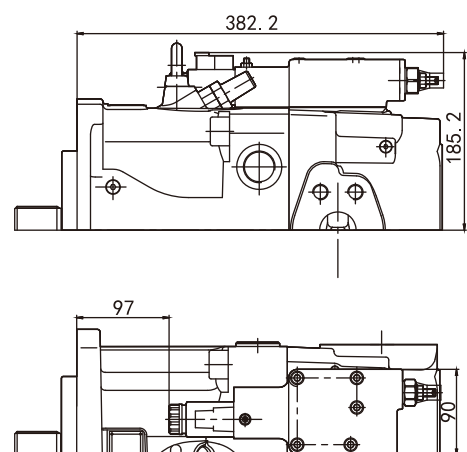

External control port G: M14x1.5,12deep(see connection dimensions diagram for its position; plugged before delivery)

> Installation Dimensions

Size 260
 N00, LRDS control
 With charge pump

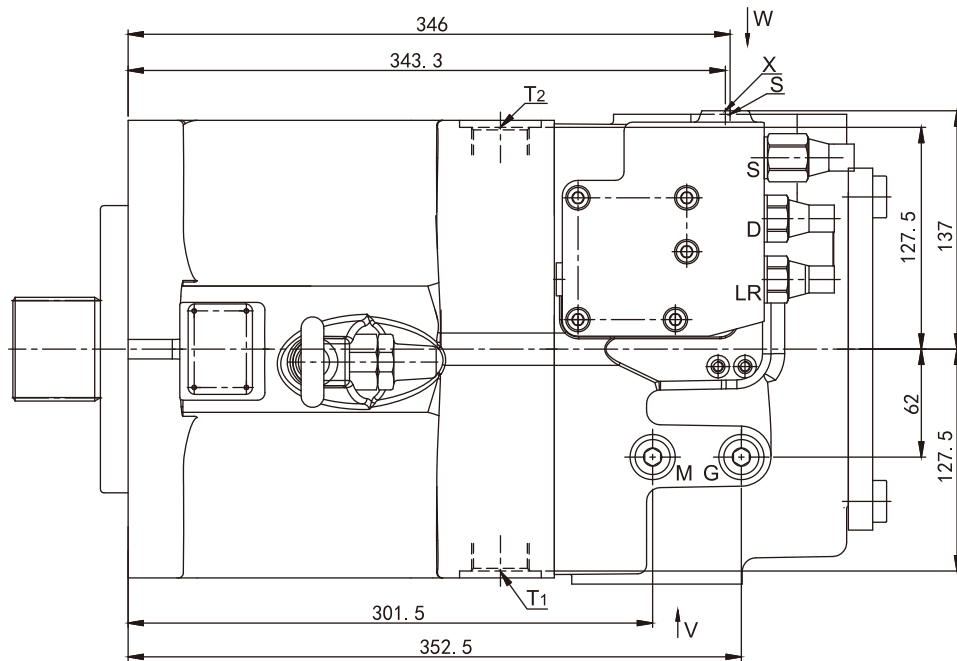
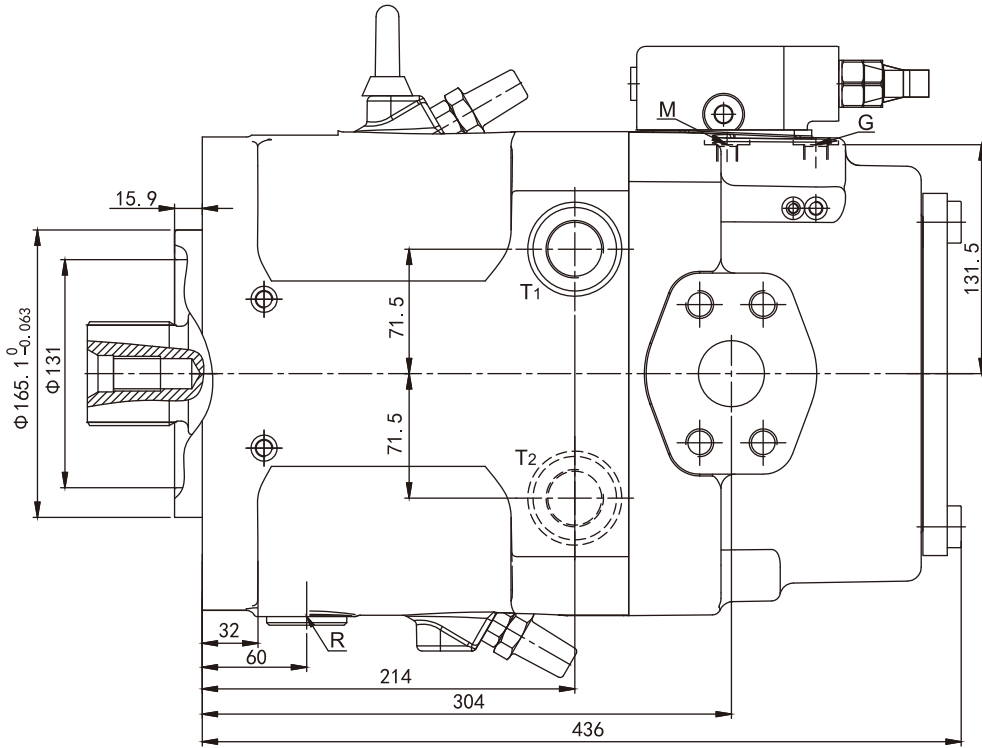

► Installation Dimensions

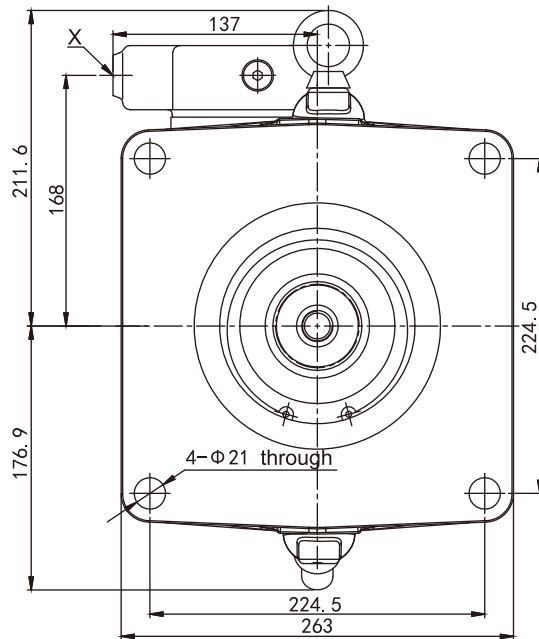

Detail W

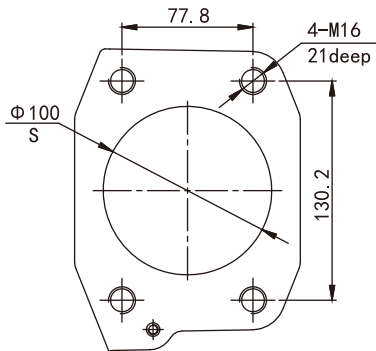

Detail V

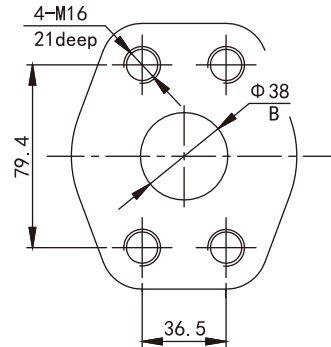

Ports SAE J518		
B	Working port (high pressure series)	1 1/2"
	Fastening thread	M16,21deep
S	Suction port (standard)	4"
	Fastening thread	M16,21deep
T1/T2	Case drain port	M33x2,16deep
R	Drain port/Air bleed port	M33x2,16deep
M1	Pressure measuring position, positioning chamber	M12x1.5,12deep
M	Pressure measuring position, working port	M12x1.5,12deep
X	Pilot pressure port	M14x1.5,12deep

LRDS constant power control

With pressure control and load sensitive control

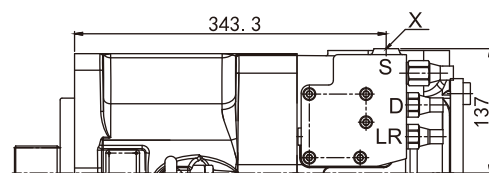
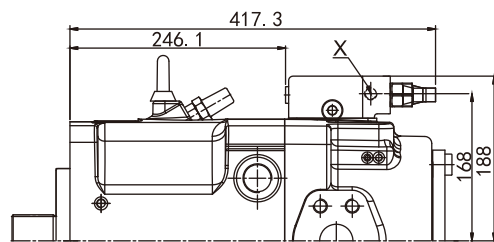

Pilot pressure port X: M14x1.5,12deep

Splined shaft Z
DIN 5480
W60x2x30x28x9g

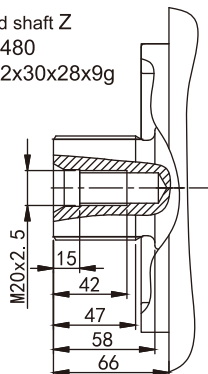

DIN 5480-2006, 30°pressure angle, flat root, side fit, tolerance class 9g

> Dimensions of Through Drive

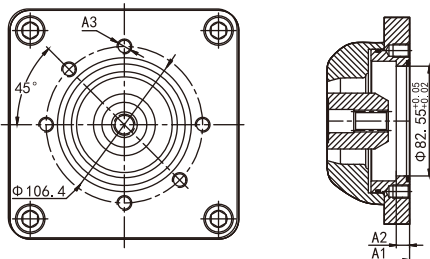
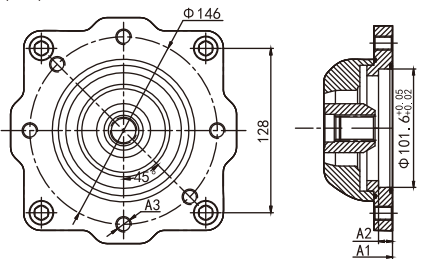
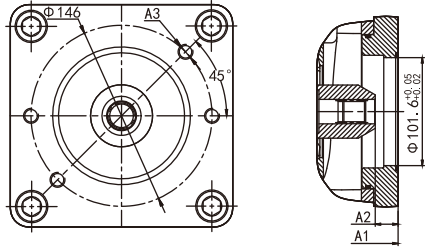
Flange SAE J744-82-2 (A)	Splined shaft ANSI B92.1a	5/8" 9T 16/32DP SAE J744-16-4(A)	K01				
		3/4" 11T 16/32DP SAE J744-19-4(A-B)	K52				
Adapter plate, sizes 60-165 		Size	A1		A2	A3	
			K01	K52		M10x1.5	
		60	258	258	10	12.5deep	
		95/115/125	306	306	10	12.5deep	
		130/145/165	329	329	10	12.5deep	
		130/145/165*	363	363	10	12.5deep	
		190*	394	394	-	13deep	
		260*	-	-	-	-	
		* with charge pump					
Flange SAE J744-101-2(B)	Splined shaft ANSI B92.1a	7/8" 13T 16/32DP SAE J744-22-4(B)	K02				
		1" 15T 16/32DP SAE J744-25-4(B-B)	K04				
Adapter plate, sizes 60-165 		W35x2x30x16x9g	K79				
		Size	A1		A2	A3	
			K02	K04	K79	M12x1.75	
		60	265	257	257	12	18deep
		95/115/125	303	303	-	12	16deep
		130/145/165	326	326	326	12	16deep
		130/145/165*	360	360	360	12	16deep
		* with charge pump					
Adapter plate, sizes 190-260 		Size	A1		A2	A3	
			K02	K04	K79		M12x1.75
		190*	404	404	404	13.5	16deep
		260*	-	-	-	-	-
		* with charge pump					

➤ Dimensions of Through Drive

Flange SAE J744-127-2(C)	Splined shaft ANSI B92.1a	1 1/4" 14T 12/24DP SAE J744-32-4(C)	K07						
		1 1/2" 17T 12/24DP SAE J744-38-4(C-C)	K24						
	Splined shaft DIN 5480	W30x2x30x14x9g	K80						
		W35x2x30x16x9g	K61						
Adapter plate, sizes 130-165		Size	A1				A2	A3	
			K07	K24	K80	K61		M16x2	
		130/145/165	335	335	335	2335	14	25deep	
		130/145/165*	369	369	369	369	14	25deep	
		* with charge pump							
Flange SAE J744-127-2-4(A)		See table above for couplings for splined shaft							
		Size	A1				A2	A3	A4
			K07	K24	K80	K61		M16x2	M12x1.75
		60	273	-	-	-	13	15deep	15deep
		95/115/125	318	-	318	318	13	25deep	15deep
		130/145/165	341	341	341	341	13	25deep	15deep
		130/145/165*	375	375	375	375	13	25deep	15deep
		190*	404	404	404	404	14	23deep	23deep
		260*	-	-	-	-	-	-	-
		* with charge pump							
Flange SAE J744-152-4(D)	Splined shaft ANSI B92.1a	1 1/4" 14T 12/24DP SAE J744-32-4(C)	K86						
		1 3/4" 13T 8/16DP SAE J744-44-4(D)	K17						
	Splined shaft DIN 5480	W40x2x30x18x9g	K81						
		W45x2x30x21x9g	K82						
		W50x2x30x24x9g	K83						
		Size	A1				A2	A4	
			K86	K17	K81	K82	K83		M20
		95/115/125	317	-	-	317	-	14	25deep
		130/145/165	340	350	-	340	340	13	25deep
		130/145/165*	374	384	-	374	374	13	25deep
		190*	-	-	-	424	-	15	35deep
			429	429	-	-	429	15	25deep
260*	-	-	-	-	-	-	-		
		* with charge pump							
Flange	Splined shaft ANSI B92.1a	13/4" 13T 8/16DP SAE J744-44-4(D)	K72						
		W50x2x30x24x9g	K84						
	Splined shaft DIN 5480	W60x2x30x28x9g	K67						
		Size	A1			A2	A3		
			K72	K84	K67		M20		
		190*	-	419	-	19	30deep		
		260*	-	-	-	-	-		
		* with charge pump							

> Connector for Solenoids

DEUTSCH DT04-2P-EP04, 2 pin
 molded, without bidirectional suppressor diode(standard)_____P
 Type of protection according to DIN/EN 60529: IP67 and IP69K

Circuit diagram symbol

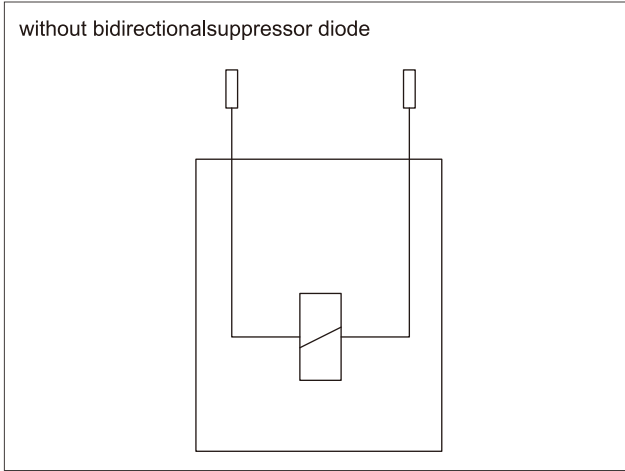

Mating connector

DEUTSCH DT06-2S-EP04
 The mating connector is not included in the delivery contents.

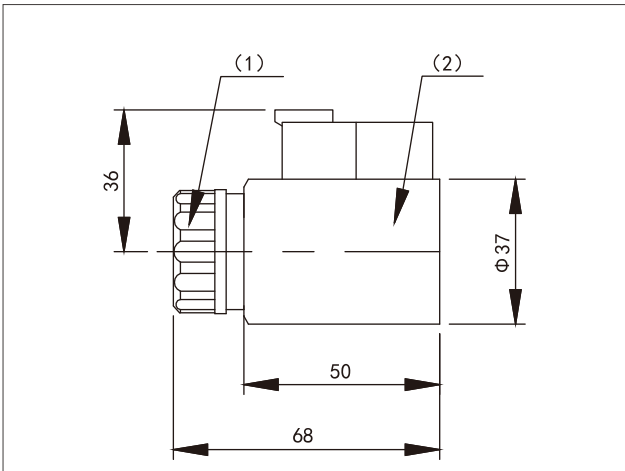

Note for round solenoids:
 The position of the connector can be changed by turning the solenoid body.
 Proceed as follows:
 1.Loosen fixing nut (1)
 2.Turn the solenoid body (2) to the desired position
 3.Tighten the fixing nut
 Tightening torque of fixing nut: 5⁺¹ Nm
 (width across the flats WAF26, 12kt DIN 3124)

Installation Instructions

General

The axial piston unit must always be filled with hydraulic fluid and air bled during commissioning and operation. This must also be observed following a longer standstill as the system may empty via the hydraulic lines.

The leakage in the housing must be directed to the reservoir via the highest drain port (T1/T2). The minimum suction pressure at port S must not fall below 0.8 bar absolute pressure (without charge pump) or 0.6 bar (with charge pump).

Under all operating conditions, the suction line and case drain line must flow into the reservoir below the minimum fluid level.

Above-reservoir installation

Pump above the minimum fluid level of the reservoir.

Observe the maximum permissible suction height $h_{a\ min}=800\text{mm}$.

HP1VAO (with charge pump) is not designed to be installed above the reservoir. Recommendation for installation position 7 (shaft upwards): The check valve in the drain line (cracking pressure: 0.5 bar) can prevent draining inside the housing.

For control options with pressure controller, displacement limiter and EP controller, the minimum displacement setting must be $V_g \geq 5\% V_{g\ max}$.

Below-reservoir installation (standard)

Pump below the minimum fluid level of the reservoir. Recommended installation positions: 1 and 2.

Installation position

See the examples below. Other installation positions may be provided as required.

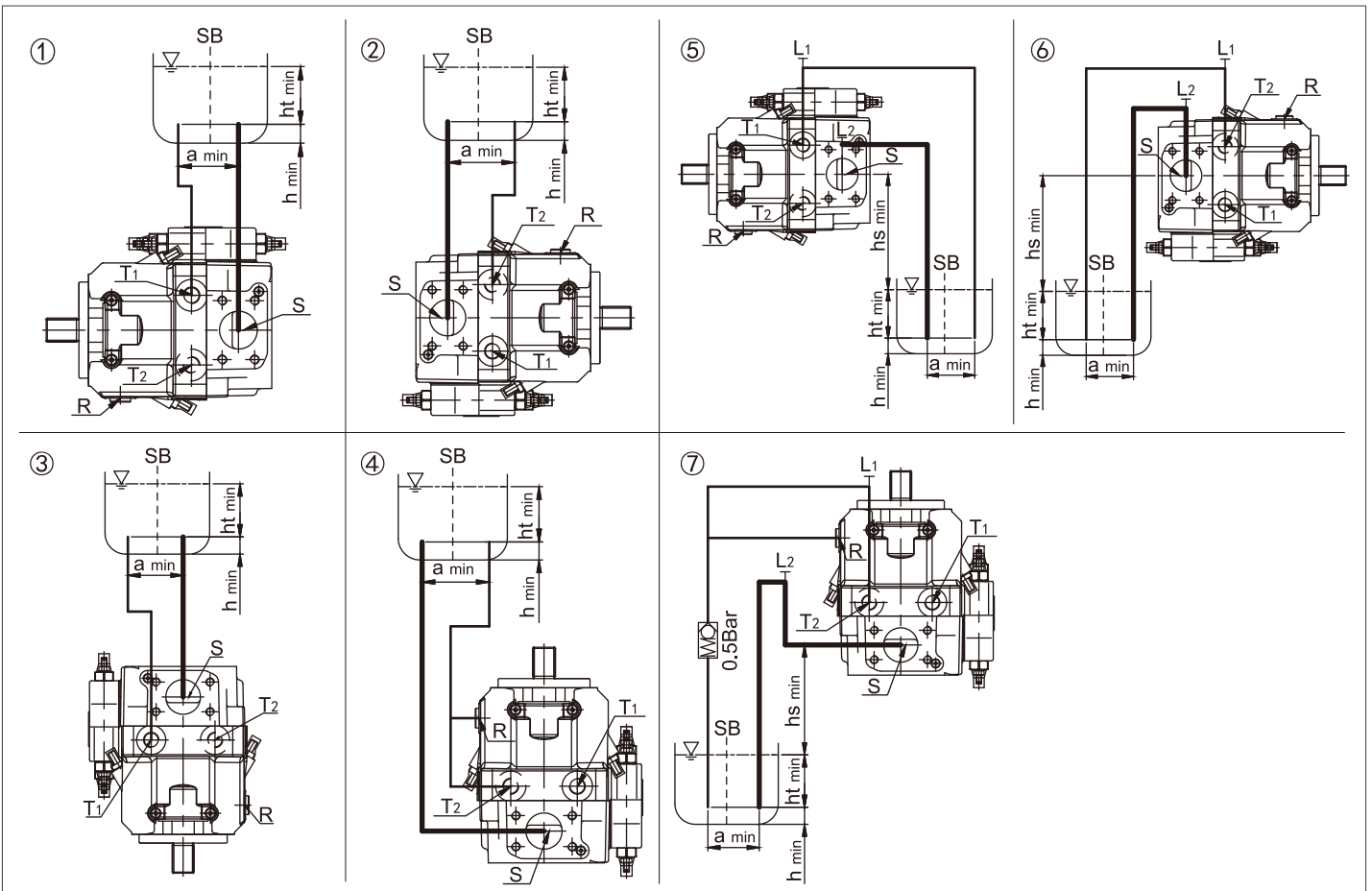

$h_{s\ max}=800\text{mm}$, $h_{t\ min}=200\text{mm}$, $h_{min}=100\text{mm}$, SB=Silencer plate (baffle plate)

When designing the tank, ensure adequate space a_{min} between the suction line and the case drain line to prevent the heated, returned fluid from being directly drawn back out.

Installation Position	Air Bleeding	Filling
①	T1	S+T1
②	R	S+T2
③	T1/T2	S+T1/T2
④	R	S+T1/T2

Installation Position	Air Bleeding	Filling
⑤	L1+L2	L2 (S)+L1 (T1)
⑥	R+L2	L2 (S)+L1 (T2)
⑦	L1+L2	L2 (S)+L1 (T1/T2)

Installation Instructions

Tank installation

Pump below the minimum fluid level in the tank.

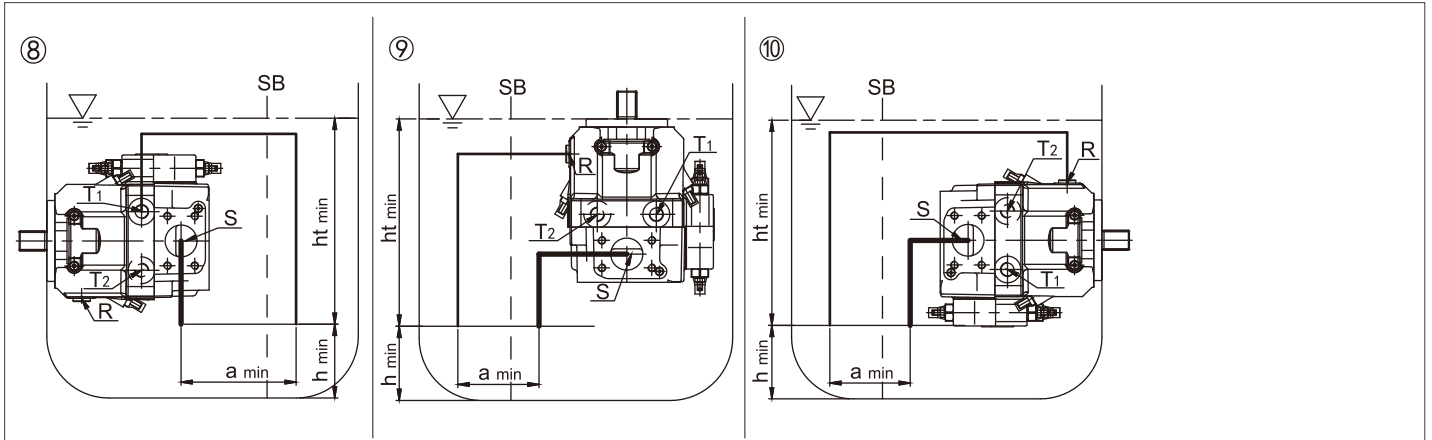

$ht_{min}=200\text{mm}$, $h_{min}=100\text{mm}$, SB=Silencer plate (baffle plate)

When designing the tank, ensure adequate space a_{min} between the suction line and the case drain line to prevent the heated, returned fluid from being directly drawn back out.

Installation Position	Air Bleeding	Filling
⑧	T ₁	automatically via all open T ₁ , T ₂ , R and S ports, though position below the hydraulic fluid level
⑨	R	
⑩	R	

HP1VO is designed to be used in open circuits.

Project planning, assembly and commissioning of the axial piston unit require the involvement of qualified personnel.

The service line ports and function ports are only designed to accommodate hydraulic lines.

During and shortly after operation, there is a risk of burns on the axial piston unit and especially on the solenoids. Take appropriate safety measures (e. g. by wearing protective clothing).

Depending on the operational state of the axial piston unit (operating pressure, fluid temperature), the characteristic may shift.

Pressure ports:

The ports and fixing threads are designed for the specified maximum pressure. The machine or system manufacturer must ensure that the connecting elements and lines correspond to the specified operating conditions (pressure, flow, hydraulic fluid, temperature) with the necessary safety factors. The data and notes contained herein must be adhered to.

The following tightening torques apply:

Threaded hole for axial piston unit:

The maximum permissible tightening torques $M_{G\max}$ are maximum values for the threaded holes and must not be exceeded.

For values, see the following table.

Fittings:

Observe the manufacturer's instruction regarding the tightening torques of the used fittings.

Fixing screws:

For fixing screws according to DIN 13, we recommend checking the tightening torque individually according to VDI 2230.

Locking screws:

For the metal locking screws supplied with the axial piston unit, the required tightening torques of locking screws M_v apply.

For values, see the following table.

The product is not approved as a component for the safety concept of a general machine according to DIN EN ISO 13849.

Thread size		Max. permissible tightening torque of the screw thread $M_{G\max}$	Required tightening torque for locking screws M_v	WAF Hexagon socket
M12x1.5	DIN 3852	50Nm	25Nm	6mm
M14x1.5		80Nm	35Nm	6mm
M22x1.5		210Nm	80Nm	10mm
M26x1.5		230Nm	120Nm	12mm
M33x2		540Nm	310Nm	17mm

Since 2002

Over twenty years of deep cultivation in the field of hydraulic Solutions

HYTEK is a high technology enterprise integrating R&D, production, sales and service of hydraulic power products. Provides professional hydraulic transmission control products and solutions for construction machinery, road machinery, material handling machinery, agricultural and forestry machinery, industrial equipment and other fields. After more than 20 years of continuous R&D, technological innovation, market development and application services, technical level and the scale of production and sales have been on the forefront of the industry. Hytek has been committed to helping the development of subdivided industries with innovative hydraulic technology, "focusing on the challenges and pressures of customers, providing competitive products and solutions, reducing costs and increasing efficiency for customers, and continuously creating maximum value".

Product Series

- Open Circuit Pump
- Closed Circuit Pump
- Fixed Displacement Motor
- Variable Displacement Motor
- Hydrostatic Transmission Unit
- Internal Gear Pump
- Vane Pump
- Proportional valve/
Industrial Hydraulic Valve

Please visit the official website : en.hytek.cn

HYTEK POWER CO.,LTD.

No.156,West Yuele Street,Lucheng District,Wenzhoucity 325029,Zhejiang,CHINA
Email: globalsales@hytek.cn

HYTEK-REV1.0 03/2025

If there are any other modifications,no further notice will be given.