

# Axial Piston Fixed Motor HAA2FM Series 61/69/63/10

Series: 61/69

Size: 45-90 mL/r

Rated pressure: 30 MPa

Max. pressure: 35 MPa

Series: 63

Size: 45-90 mL/r

Rated pressure: 40 MPa

Max. pressure: 45 MPa

Series: 10

Size: 80-107 mL/r

Rated pressure: 30 MPa

Max. pressure: 35 MPa



## Features



- Axial piston motor of bent-axis design for hydrostatic drives in open and closed circuits
- The output speed results from pump flow and motor displacement
- The output torque increases with the pressure differential between the high- and low-pressure sides and with increasing displacement
- High power to weight ratio
- Integrated piston design with piston ring makes it compact in structure
- High starting torque efficiency and high total efficiency

## Contents



- Model Code.....02
- Structure.....06
- Technical Data.....08
- Installation Dimensions,45.....09
- Installation Dimensions,56/63/80.....10
- Installation Dimensions,80/90.....11
- Installation Dimensions,107.....12
- Flushing and Boost-pressure Valve.....13

## > Model Code

	c	A	I	K	M	N	P	R	V	Z	Zaa
HAA2F	M	-	/	W	-		D			-	+

### Axial piston unit

—	Bent-axis design, fixed displacement piston motor	HAA2F
---	---	-------

### Operating mode

C		23	28	32	45	56	63	80	90	107	
	flange	○	○	○	●	●	●	●	●	●	M

### Displacement

A	Geometric displacement, in mL/r	23	28	32	45	56	63	80	90	107	
		○	○	○	●	●	●	●	●	●	

### Series

I		23	28	32	45	56	63	80	90	107	
	7-piston 30MPa	○	○	○	●	●	●	●	●	○	61
	7-piston 40MPa	○	○	○	●	●	●	●	●	○	63
	9-piston 30MPa	○	○	○	○	●	○	●	●	○	69
	7-piston(Expansion of displacement) 30MPa	○	○	○	○	○	○	●	○	●	10

### Direction of rotation (viewed on drive shaft)

K		23	28	32	45	56	63	80	90	107	
	Bi-directional	○	○	○	●	●	●	●	●	●	W

### Sealing material

M		23	28	32	45	56	63	80	90	107	
	NBR seal + FKM Shaft seal	○	○	○	○	○	○	○	○	○	N
	NBR seal	○	○	○	●	●	●	●	●	○	P
	FKM seal	○	○	○	●	●	●	●	●	●	V

### Drive shaft

N		23	28	32	45	56	63	80	90	107	
	Parallel keyed shaft DIN 6885	○	○	○	○	●	○	○	○	○	B
	Splined shaft SAE J744(ANSI B92.1a)										
	1 1/4" 14T 12/24DP	○	○	○	●	●	●	○	○	○	S
	1 3/8" 21T 16/32DP	○	○	○	●	●	●	○	○	○	T
	1 1/4" 14T 12/24DP	○	○	○	○	○	○	●	●	○	Q
	1 3/8" 21T 16/32DP	○	○	○	○	○	○	●	●	●	U
1 1/2" 23T 16/32DP	○	○	○	○	○	○	●	●	●	S	

## Model Code

	c		A		I	K		M	N	P	R	V		Z		Zaa
HAA2F	M	-		/		W	-			D			-		+	

### Mounting flange

P		23	28	32	45	56	63	80	90	107	
	4-hole, SAE J744	○	○	○	●	●	●	○	○	○	D
		○	○	○	○	○	○	●	●	●	X

### Working port

R		23	28	32	45	56	63	80	90	107		
	SAE flange ports A/B at rear	○	○	○	●	●	●	●	●	○	010	
	SAE flange ports A/B at side	○	○	○	●	●	●	●	●	●	020	
	SAE flange ports A/B at side <sup>1)</sup>	○	○	○	●	●	●	●	●	●	027	
	Metric threaded ports A/B at side	○	○	○	●	●	○	○	○	○	030	
	Metric threaded ports A/B at side <sup>1)</sup>	○	○	○	○	○	○	○	○	○	037	
	Metric threaded ports A/B at side and rear <sup>2)</sup>	○	○	○	●	●	○	○	○	○	040	
	SAE flange ports A/B at bottom	○	○	○	●	●	●	●	●	●	100	
	With 1-stage pressure relief valve <sup>3)</sup> Port plate without counterbalance valve	○	○	○	○	○	○	○	○	○	●	171
	With 1-stage pressure relief valve <sup>3)</sup> Port plate with HBVD counterbalance valve	○	○	○	○	○	○	○	○	○	●	178
	With 1-stage pressure relief valve <sup>3)</sup> Port plate without counterbalance valve	○	○	○	○	○	○	○	●	●	●	181
	With 1-stage pressure relief valve <sup>3)</sup> Port plate with HBVD counterbalance valve	○	○	○	○	○	○	○	●	●	●	188
	With 1-stage pressure relief valve <sup>3)</sup>	○	○	○	○	○	○	○	○	●	○	191
	With 2-stage pressure relief valve (with pressure boost facility)	○	○	○	○	○	○	○	○	○	○	192

Valve	Without valve	0
	Pressure relief valve (without pressure boost facility)	1
	Pressure relief valve (with pressure boost facility)	2
	With flushing valve	7
	With counterbalance valve	8

1) : With flushing valve

2) : Side threads plugged

3) : Without pressure boost facility

**> Model Code**

	c	A	I	K	M	N	P	R	V	Z	Zaa
<b>HAA2F</b>	<b>M</b>	-	/	<b>W</b>	-		<b>D</b>		-	+	

**Speed sensor**

V		23	28	32	45	56	63	80	90	107	
	Without speed sensor(without code)	○	○	○	●	●	●	●	●	●	
	Prepared for HDD speed sensor	○	○	○	●	●	○	●	●	●	F0
	With speed sensor(without connector)	○	○	○	●	●	○	●	●	●	F
	With HDD speed sensor(DT04-4P connector)	○	○	○	●	●	○	●	●	●	F1
	With HDD speed sensor(DTM04-4P connector)	○	○	○	●	●	○	●	●	●	F2

**Special configuration**

Z		23	28	32	45	56	63	80	90	107	
	No special configuration(without code)	○	○	○	●	●	●	●	●	●	
	Low-pressure flushing 0.8 MPa	○	○	○	○	●	○	○	○	○	A
	Flow of flushing valve 3 L/min	○	○	○	○	○	○	○	○	○	-C030
	Flow of flushing valve 3.5 L/min	○	○	○	○	○	○	●	○	○	-C035
	Flow of flushing valve 5 L/min	○	○	○	○	○	○	●	●	○	-C050
	Flow of flushing valve 8 L/min	○	○	○	○	○	●	●	●	●	-C080
	Flow of flushing valve 10 L/min	○	○	○	○	○	●	●	○	○	-C100
	End cap with differential valve (constant rotational speed)	○	○	○	○	○	○	○	○	○	-CS
	End cap with on/off valve	○	○	○	○	○	○	○	○	○	-DS
	Special configuration	○	○	○	●	●	●	●	●	○	***

**Counterbalance valve**

Zaa		23	28	32	45	56	63	80	90	107
	HBVD20W27L/41B-V01K00D0600S00A	○	○	○	○	○	○	●	●	○
	HBVD20W28L/41B-V01K00D0600S00A	○	○	○	○	○	○	○	○	●
	HBVD25W38L/41B-V16K00D1200S00A	○	○	○	○	○	○	○	○	●
	HBVD25W38L/41B-V16K00D1200S00	○	○	○	○	○	○	○	○	○
	HBVD25W38L/41B-V07K00D0600S00A	○	○	○	○	○	○	○	○	○
	HBVD25W38L/41B-V07K00D0800S00A	○	○	○	○	○	○	○	○	○

● Available    ○ On request    — Not available    ◻ Recommended model

## > Model Code

\* Number of teeth of ferromagnetic gears for motor speed sensors

Number of teeth of ferromagnetic gear	23	28	32	45	56	63	80	90	107
38	<input type="radio"/>	<input type="radio"/>	<input type="radio"/>	<input type="radio"/>	<input type="radio"/>	<input type="radio"/>	<input type="radio"/>	<input type="radio"/>	<input type="radio"/>
45	<input type="radio"/>	<input type="radio"/>	<input type="radio"/>	<input checked="" type="radio"/>	<input type="radio"/>	<input type="radio"/>	<input type="radio"/>	<input type="radio"/>	<input type="radio"/>
47	<input type="radio"/>	<input type="radio"/>	<input type="radio"/>	<input type="radio"/>	<input checked="" type="radio"/>	<input checked="" type="radio"/>	<input type="radio"/>	<input type="radio"/>	<input type="radio"/>
53	<input type="radio"/>	<input type="radio"/>	<input type="radio"/>	<input type="radio"/>	<input type="radio"/>	<input type="radio"/>	<input checked="" type="radio"/>	<input checked="" type="radio"/>	<input type="radio"/>
59	<input type="radio"/>	<input type="radio"/>	<input type="radio"/>	<input type="radio"/>	<input type="radio"/>	<input type="radio"/>	<input type="radio"/>	<input type="radio"/>	<input checked="" type="radio"/>
67	<input type="radio"/>	<input type="radio"/>	<input type="radio"/>	<input type="radio"/>	<input type="radio"/>	<input type="radio"/>	<input type="radio"/>	<input type="radio"/>	<input type="radio"/>

> Structure

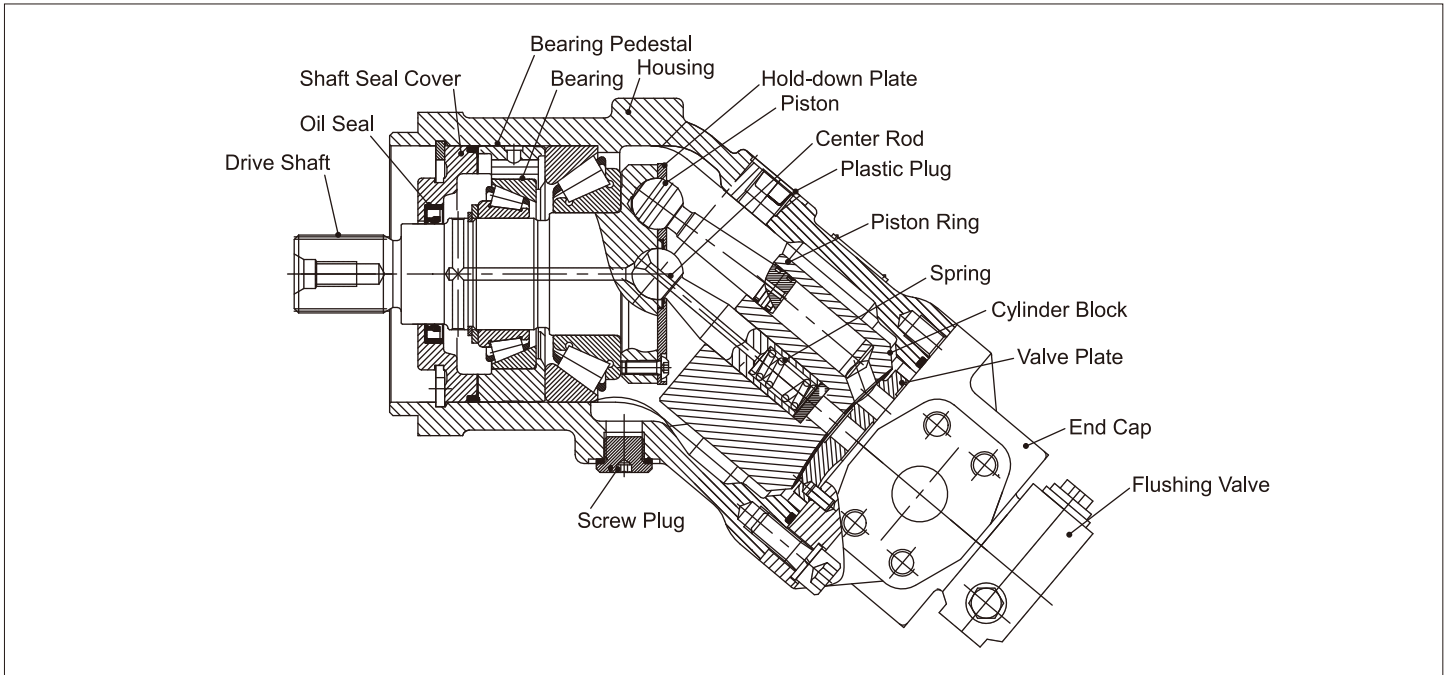

### > Hydraulic Fluid

Mineral oil

### > Working Viscosity

In order for the optimum efficiency and service life, it is recommended to select the working viscosity (at working temperature) within the range below:

$$V_{opt} = \text{optimal working viscosity } 16...36 \text{ mm}^2/\text{s}$$

It is subject to the circuit temperature of a closed circuit and the reservoir temperature of an open circuit.

### > Limit Viscosity

Limit viscosity:

$$V_{min} = 5 \text{ mm}^2/\text{s}$$

Short-term operation, permissible maximum temperature  $t_{max} = +115^\circ\text{C}$

$$V_{max} = 1600 \text{ mm}^2/\text{s}$$

Short-term operation, cold start ( $t_{min} = -40^\circ\text{C}$ )

### > Selection Diagram

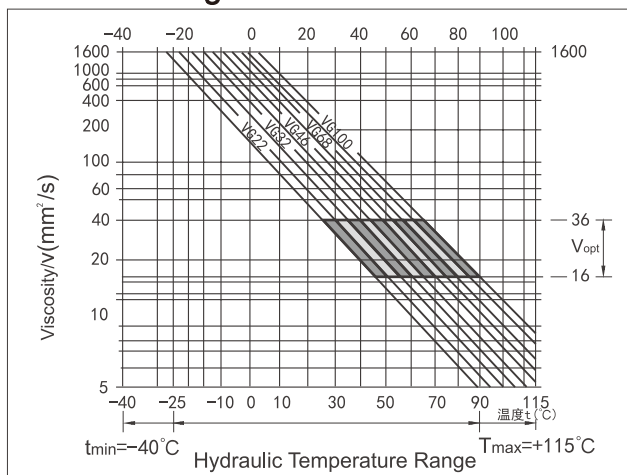

### > Instructions on Selection of Hydraulic Fluid

The working temperature dependent on the ambient temperature is required for correct selection of hydraulic fluid. It refers to the circuit temperature of a closed circuit and the reservoir temperature of an open circuit.

The hydraulic fluid should be so selected that the working viscosity in the working range is within the optimum range ( $V_{opt}$ , the shaded area on the selection diagram). The higher viscosity is recommended under the same conditions.

For example:

At an ambient temperature of  $X^\circ\text{C}$ , the working temperature of the circuit is  $60^\circ\text{C}$ . The viscosity within the optimum range ( $V_{opt}$ , shaded area) is VG46 or VG68 and the latter should be selected.

Note: The leakage (case drain) temperature depends on the pressure and motor speed, and it is always higher than the circuit or reservoir temperature.

### > Filtration

Finer filtration improves the cleanliness level of the hydraulic fluid, thus increasing the service life of the axial piston unit. To ensure normal operation of the axial piston unit, a cleanliness level of at least 9 according to NAS 1638 or 18/15 according to ISO/DIS 4406 is to be maintained.

When the hydraulic fluid has a high temperature, the cleanliness level should at least reach 8 according to NAS 1638 or 17/14 according to ISO/DIS 4406.

### > Working Pressure Range

Max. pressure at working port A or B

Size	Drive shaft	Nominal Pressure P <sub>N</sub>	Max. Pressure P <sub>max</sub>
56/63	S	35MPa	40MPa
	T	40MPa	45MPa
80/90	T	40MPa	45MPa
	S	30MPa	30MPa

### > Flow Direction

CW rotation \_\_\_\_\_ A to B  
 CCW rotation \_\_\_\_\_ B to A

### > Speed Range

No limit to minimum speed  $n_{min}$ . If uniformity of motion is required,  $n_{min}$  must not be less than 50 rpm.  
 See the operating parameters for the maximum speed.

### > Shaft Seal

Permissible pressure load

The motor speed and case drain pressure affect the service life of the shaft seal. The permissible case drain pressure for intermittent operation depends on motor speed.

For short-term operation ( $t < 5 \text{ min}$ ), the permissible absolute pressure peak may reach 1 MPa. The case pressure must be equal to or higher than the external pressure of the shaft seal.

### > Symbols

Port connection

A/B \_\_\_\_\_ working port  
 T \_\_\_\_\_ drain port

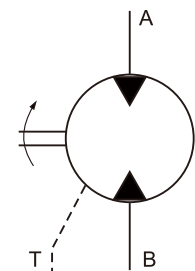

**► Technical Data**

Size			Unit	45	56	63	80	90	107
Displacement		$V_{g\ max}$	mL/r	45.6	56.1	63.0	80.4	90.0	106.7
Maximum speed		$n_{max}$	rpm	5600	5000	5000	4500	4500	4000
		$n_{max}^{1)}$ Intermittent	rpm	6200	5500	5500	5000	5000	4400
Maximum flow	at $n_{max}$	$q_{v\ max}$	L/min	255	280	315	360	405	427
Equivalent torque Torque at		$T_k$	Nm/MPa	7.25	8.9	10.0	12.7	17.0	19.9
	$\Delta p=35\text{MPa}$	$T$	Nm	254	312	350	445	501	595
	$\Delta p=40\text{MPa}$	$T$	Nm	290	356	400	508	572	680
Case volume			L	0.33	0.45	0.45	0.55	0.55	0.8
Moment of inertia of drive shaft		$J$	kgm <sup>2</sup>	0.0024	0.0042	0.0042	0.0072	0.0072	0.0116
Weight		$M$	kg	13.5	18	18	23	23	32

1) : Intermittent maximum speed: overspeed for unloading and overhauling processing,  $t < 5\text{s}$  and  $\Delta p < 15\text{MPa}$

**► Specification Calculation**

Input flow	$q_v = \frac{V_g \cdot n}{1000 \cdot \eta_v}$	[L/min]	$V_g$ = Displacement per revolution, mL/r
Torque	$T = \frac{V_g \cdot \Delta p \cdot \eta_{mh}}{20 \cdot \pi}$	[Nm]	$\Delta p$ = Differential pressure, MPa
Power	$P = \frac{2\pi \cdot T \cdot n}{60000} = \frac{q_v \cdot \Delta p \cdot \eta_t}{600}$	[KW]	$n$ = Speed, rpm
			$\eta_v$ = Volumetric efficiency
			$\eta_{mh}$ = Mechanical-hydraulic efficiency
			$\eta_t$ = Total efficiency

**► Minimum Inlet Pressure at Port A(B)**

A minimum inlet pressure must be ensured at the fluid inlet to avoid damaging the motor.  
The minimum inlet pressure is related to motor speed.



➤ Installation Dimensions

HAA2FM 45  
S6\*Series

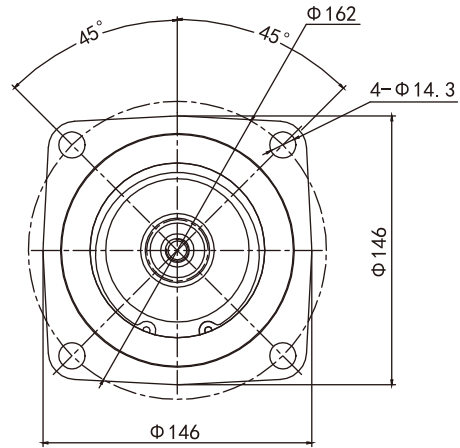
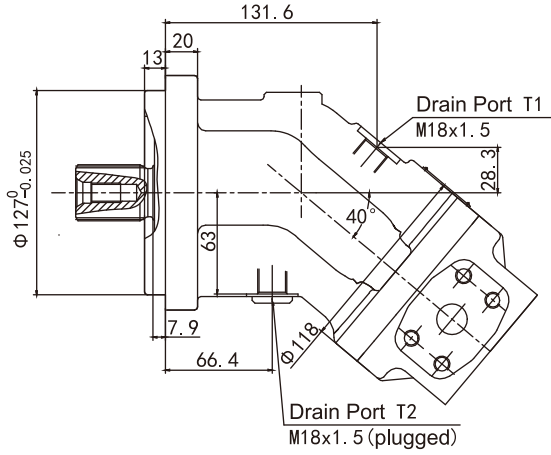

Port Plate

020 SAE port flange, at side

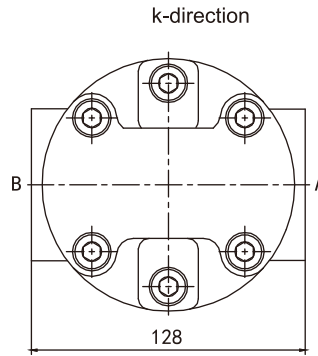
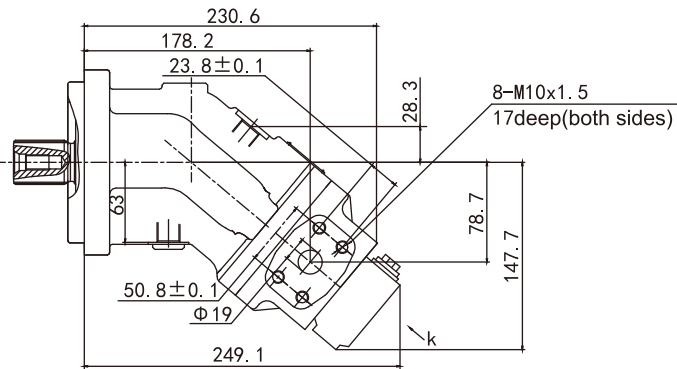

A/B Working port (high pressure series) SAE 1"  
Fastening thread M12,17deep

Drive shaft

Splined shaft S 1 1/4" 14T 12/24DP

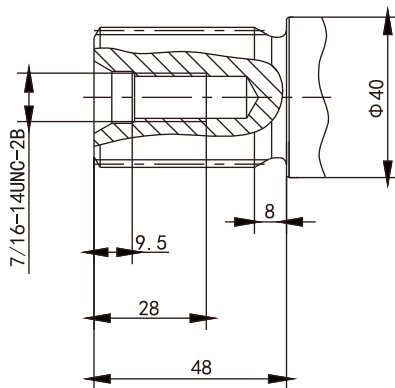

P<sub>N</sub>=35MPa

Splined shaft T 1 3/8" 21T 16/32DP

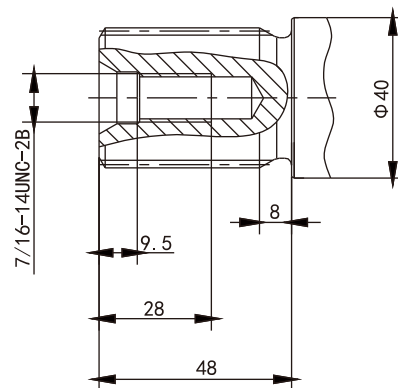

P<sub>N</sub>=40MPa

**Installation Dimensions**

HAA2FM 56/63 S6\*Series  
HAA2FM 80 S10 Series

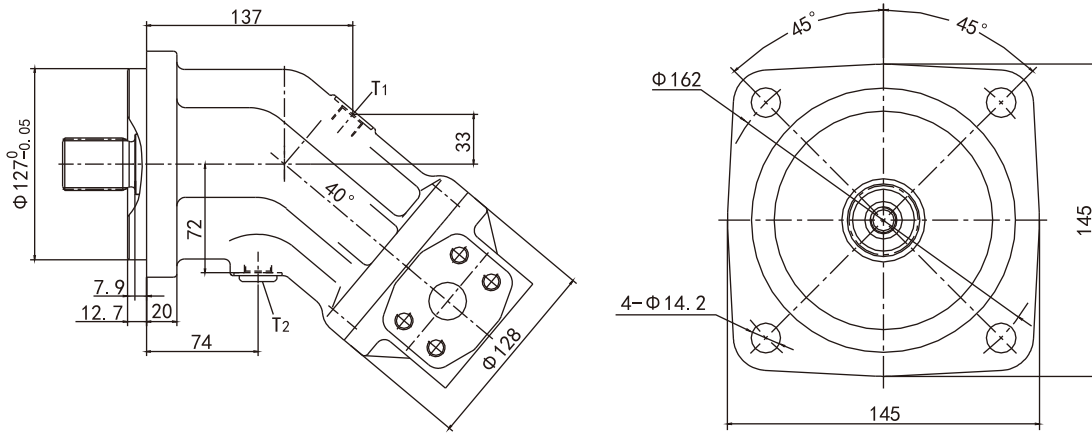

Ports  
A/B Working port (see port plate)  
T1/T2 Drain port (T2 plugged) M18x1.5, 15deep

**Port Plate**

020 SAE flange, at side

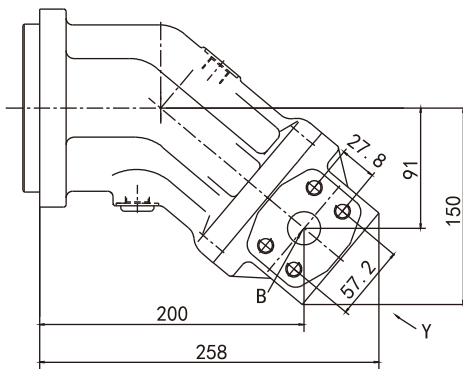

Y-direction

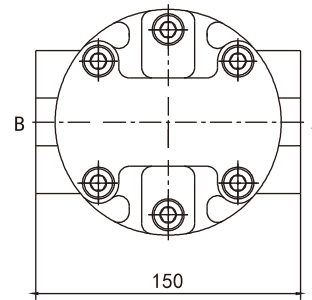

A/B Working port (high pressure series) SAE J518 SAE 1"  
Fastening thread M12, 17deep

**Drive shaft**

Splined shaft S  
1 1/4" 14T 12/24DP

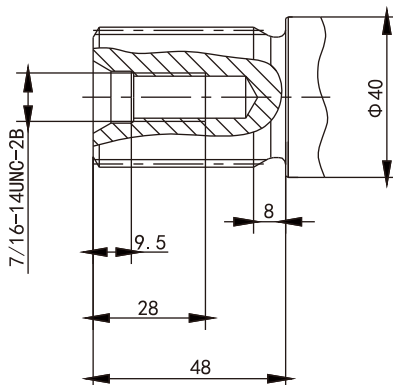

PN=35MPa

Splined shaft T  
1 3/8" 21T 16/32DP

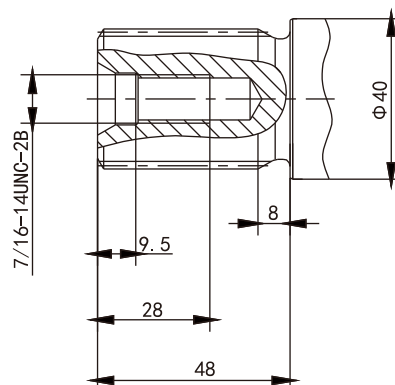

PN=40MPa

Keyed shaft B DIN6885  
AS 10x8x50

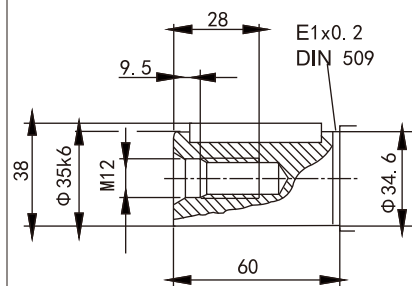

PN=35MPa

**Installation Dimensions**

HAA2FM 80/90  
S6\*Series

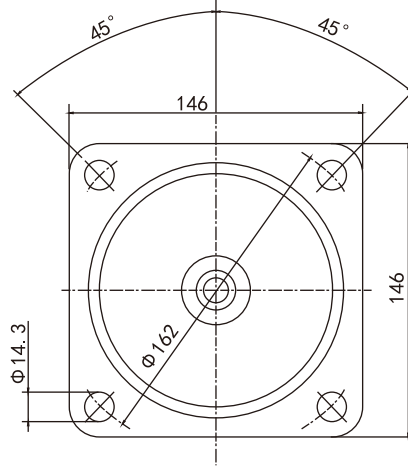
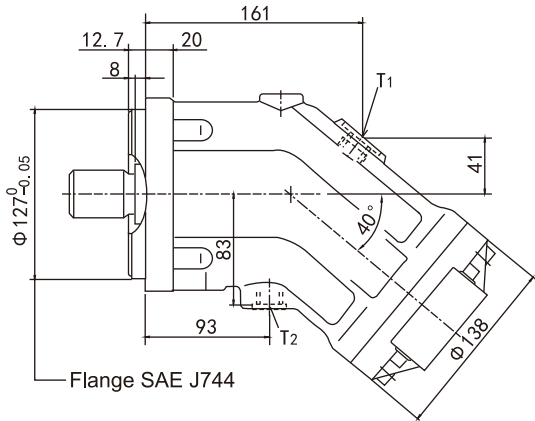

Ports  
A/B Working port (see port plate)  
T1/T2 Drain port (T2 plugged) M18x1.5, 15deep

**Port Plate**

020 SAE flange, at side

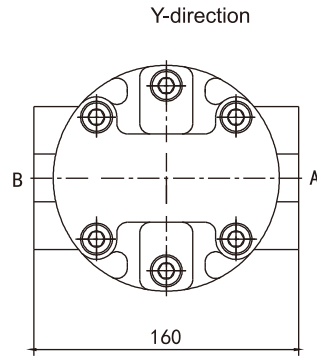
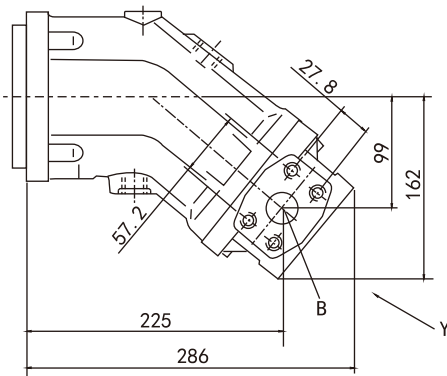

A/B Working port (high pressure series) SAE J518 SAE 1"  
Fastening thread M12, 17deep

**Drive shaft**

Splined shaft U  
1 3/8" 21T 16/32DP

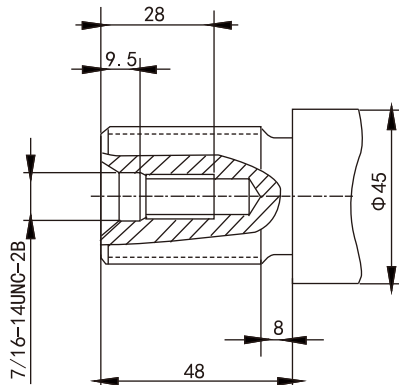

$P_N=40\text{MPa}$

Splined shaft Q  
1 1/4" 14T 12/24DP

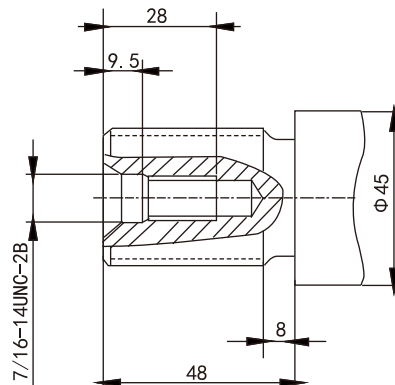

80:  $P_N=30\text{MPa}$   
90:  $P_N=28\text{MPa}$

Splined shaft S\*  
1 1/2" 23T 16/32DP

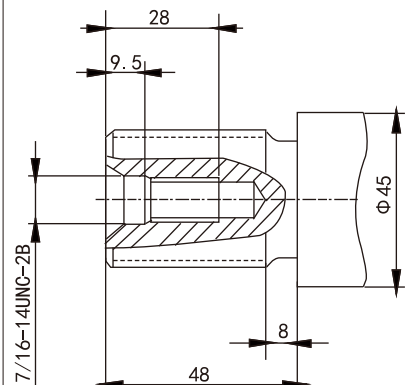

$P_N=40\text{MPa}$

**Installation Dimensions**

**HAA2FM 107  
S10 Series**

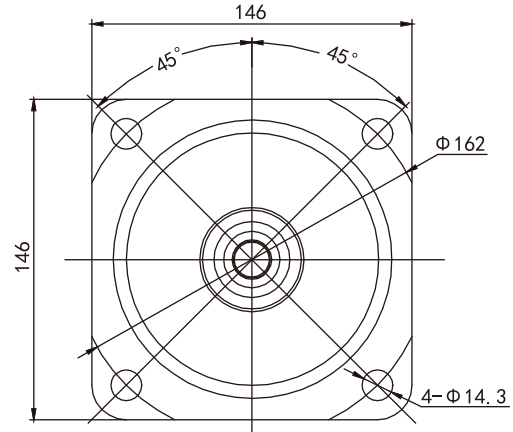
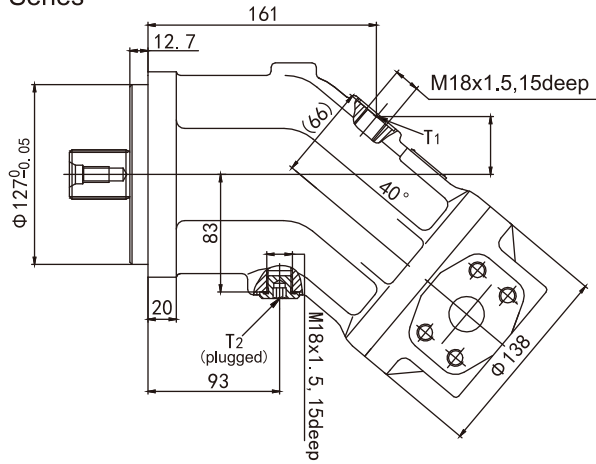

**Port Plate**

020 SAE flange, at side

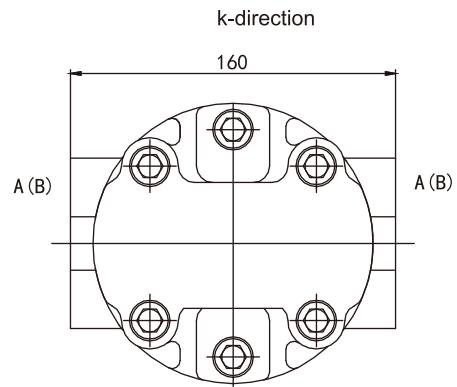
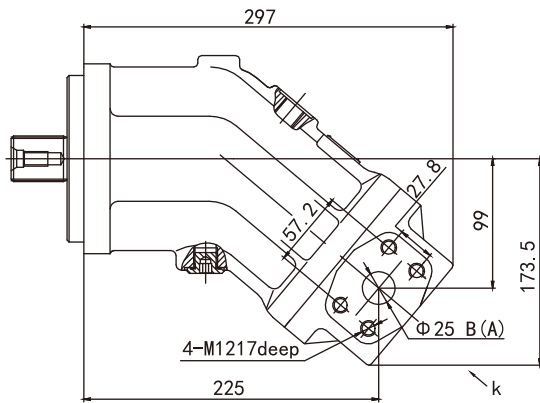

A/B Working port (high pressure series) SAE J518 SAE 1"  
Fastening thread M12,17deep

**Drive shaft**

Splined shaft S\*  
1 1/2" 23T 16/32DP

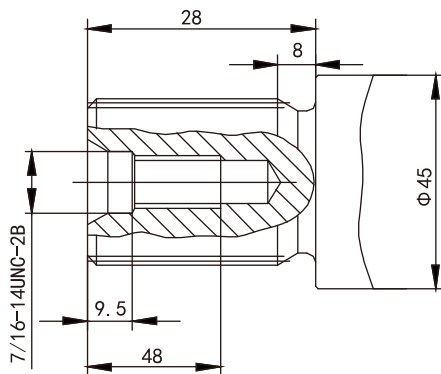

$P_N=35\text{MPa}$

Splined shaft U  
1 3/8" 21T 16/32DP

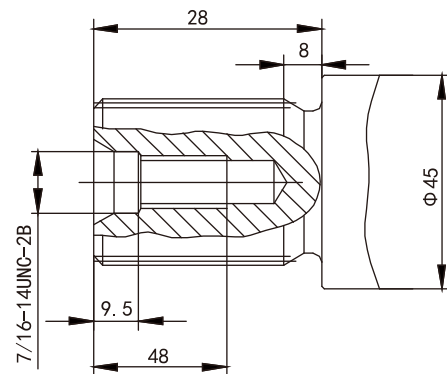

$P_N=40\text{MPa}$

## ➤ Flushing and Boost-pressure Valve

### Overview

The flushing valve is used to prevent over-temperature. The minimum boost pressure must be guaranteed for flushing of a closed circuit. Hydraulic fluid from the low-pressure side is directed into the motor housing. Then, it is fed into the reservoir together with the case drain. The removed hydraulic fluid must be made up by the boost-pressure valve.

Cracking pressure (1.6 MPa, fixed setting) of the boost-pressure valve must be considered when setting the boost pressure of the pump in a closed circuit.

### Standard flow

At low pressure  $\Delta p=2.5\text{MPa}$

Size	Flushing Flow
45/56/63	3.5L/min
80/90	5L/min
107	8L/min

Orifices can be used to adjust the flow as necessary and throttle valves of 3.5-10 L/min are available.

If nonstandard flows are required, please specify the required throttle valve when ordering.

### Circuit diagram

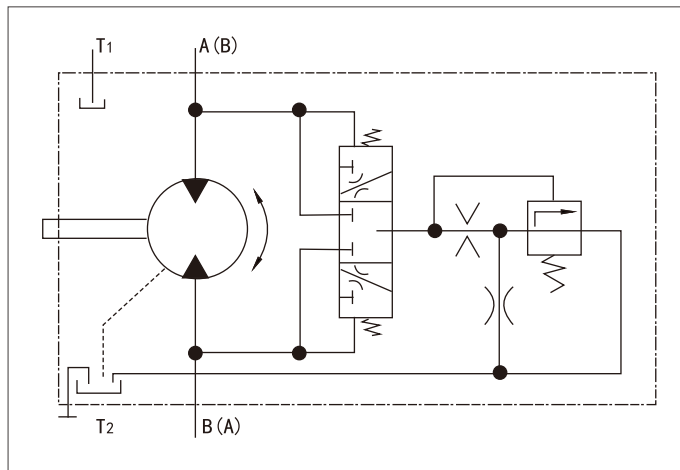

### Port plate

027: SAE flange ports, at side

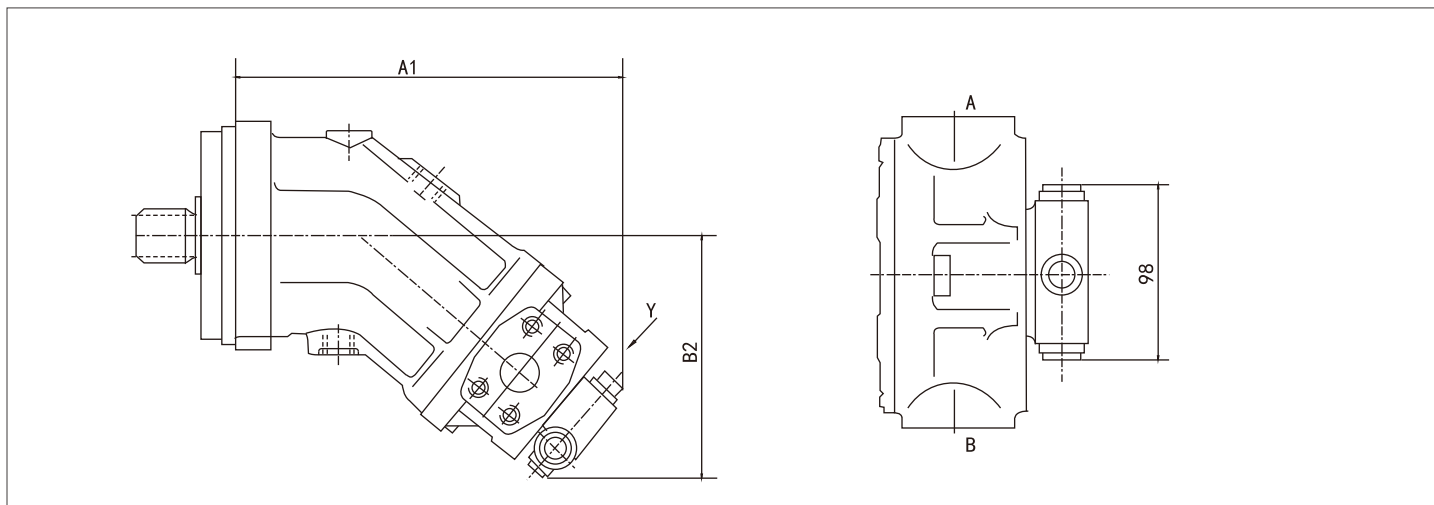

Size	A1	B2
45	249.1	147.7
45	263	159
56/63	263	159
80/90	297	173.5
107	297	173.5





## Since 2002

### Over twenty years of deep cultivation in the field of hydraulic Solutions

HYTEK is a high technology enterprise integrating R&D, production, sales and service of hydraulic power products. Provides professional hydraulic transmission control products and solutions for construction machinery, road machinery, material handling machinery, agricultural and forestry machinery, industrial equipment and other fields. After more than 20 years of continuous R&D, technological innovation, market development and application services, technical level and the scale of production and sales have been on the forefront of the industry. Hytek has been committed to helping the development of subdivided industries with innovative hydraulic technology, "focusing on the challenges and pressures of customers, providing competitive products and solutions, reducing costs and increasing efficiency for customers, and continuously creating maximum value".

#### Product Series

- Open Circuit Pump
- Closed Circuit Pump
- Fixed Displacement Motor
- Variable Displacement Motor
- Hydrostatic Transmission Unit
- Internal Gear Pump
- Vane Pump
- Proportional valve/  
Industrial Hydraulic Valve

Please visit the official website : [en.hytek.cn](http://en.hytek.cn)

#### HYTEK POWER CO.,LTD.

No.156,West Yuele Street,Lucheng District,Wenzhoucity 325029,Zhejiang,CHINA  
Email: [globalsales@hytek.cn](mailto:globalsales@hytek.cn)

HYTEK-REV1.0 03/2025

If there are any other modifications,no further notice will be given.