

## Internal Gear Pump HG

HG series internal gear pumps manifesting the high efficiency and low energy consumption of servo VFD systems are widely used on such industrial machinery as plastics machinery, shoe machinery, diecasting machinery and forklift. It is particularly suitable for the energy saving system of servo VFDs.

It is designed and developed to meet high pressure and high speed requirements of servo VFDs. The internal oil passages are further optimized based on suction and discharge flow analysis in high-speed high-pressure working conditions, and the dynamic stability of the pressure compensation mechanism is improved to enhance reliability of the products.

Displacement: 8-180 ml/r  
Max. pressure: 350 bar  
Max. speed: 3000 r/min  
Min. speed: 200 r/min



### Features

- ◆ Axial and radial pressure compensation is designed to keep high volume efficiency even at low speed and low viscosity
- ◆ Suitable for such operations as 1/2-quadrant, pressure holding and start/stop
- ◆ High-strength cast iron and unique inner noise reduction design for lower noise
- ◆ Extremely low flow and pressure fluctuation so that stable flow and pressure output can be kept even at low speed
- ◆ Insensitive to oil contamination & long life
- ◆ Through-drive available

## > Model Description

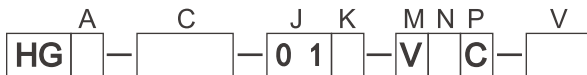

### Pump type

—	Internal gear pump	HG
---	--------------------	----

### Series

A	Size: 8...25	0
	Size: 25...63	1
	Size: 63...180	2

### Displacement

C	Series 0, Geometric displacement, ml/r	08	10	13	16	20	25
	Series 1, Geometric displacement, ml/r		25	32	40	50	63
	Series 2, Geometric displacement, ml/r	63	80	100	125	145	160

### Design code

J	01
---	----

### Input rotation direction

K		HG0	HG1	HG2	
	Clockwise(CW)	●	●	●	R
	Counterclockwise (CCW)	—	—	●	L

### Seal

M	Fluororubber	V
---	--------------	---

### Shaft

N		HG0	HG1	HG2	
	Key shaft	●	●	●	P
	Spline shaft	●	●	●	S

### Mounting flange

P	SAE 2 holes	C
---	-------------	---

### Special configuration

V		HG0	HG1	HG2	
		●	—	—	
	Reinforced locating pin	—	●	●	36

### Remarks

● Available — Not applicable □ Recommended model

> Construction

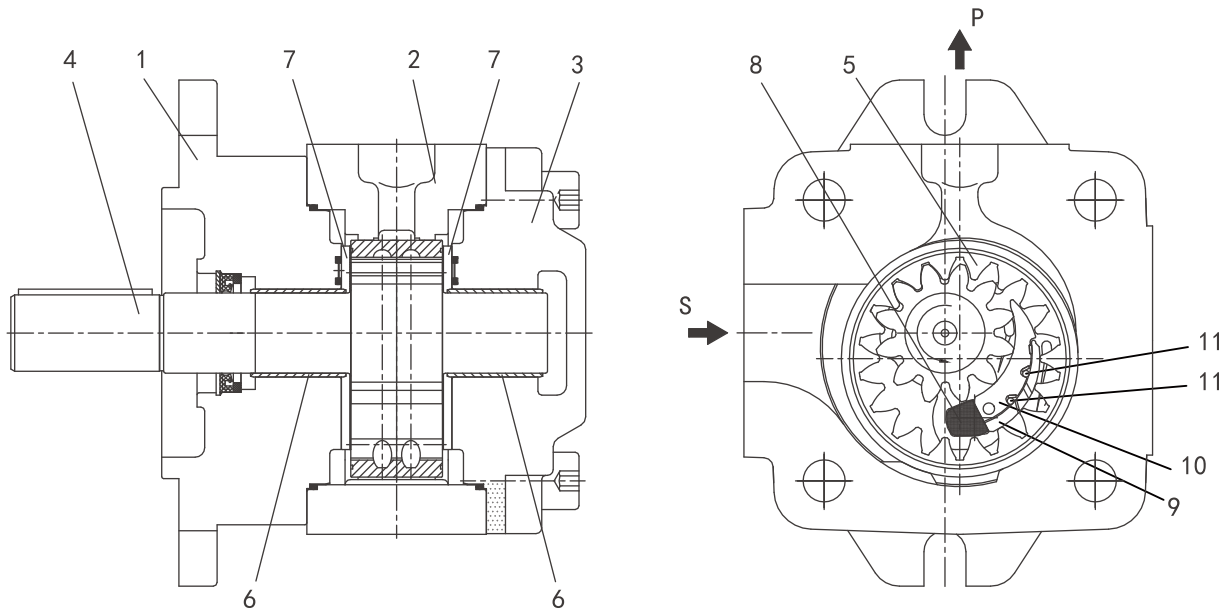

HG series hydraulic pumps are internal gear pumps with fixed displacement and clearance compensation.

Basic structure: 1- front body; 2- middle housing; 3- rear cover; 4- shaft bearing; 5- annular gear; 6- sliding bearing; 7- front and rear side plates; 8- locating rod; 9- crescent side plate; 10- crescent main plate; 11- plastic rod

> Technical Data

Design	Internal gear pump with clearance compensation
Type of connection	SAE 2-hole flange as per ISO3019-1
Pipe connection	Flange connection
Shaft load	Only radial and axial forces obtained through consultation (e.g. on belt pulley)
Rotation direction (from shaft end)	CW and CCW (as required) - not upside down
Hydraulic fluid	Petroleum base mineral oil with viscosity within the range of 10-300 mm <sup>2</sup> /s; ISO VG46 anti-wear hydraulic oil is recommended
Temperature range	Working temperature range: -10 °C-100 °C; to ensure long-term reliable operation, the optimal working temperature range is 20 °C-80 °C.
Cleanliness control	Oil cleanliness of the control system should not exceed code 9 (NAS1638) or 17/14 (ISO 4066).
Suction port pressure	Allowable absolute pressure at suction inlet: 0.8-2 bar

### > HG Series Single Pump

HG0 Series Size: 8... 25

HG1 Series Size: 25... 63

HG2 Series Size: 63... 180



### > Specification

Series		HG0					
Size		8	10	13	16	20	25
Weight	m kg	4.6	4.8	4.9	5.2	5.6	6
Speed	$n_{min}$ r/min	600	600	600	600	600	600
	$n_{max}$ r/min	3000	3000	3000	3000	3000	3000
Displacement	V cm <sup>3</sup>	8.2	10.2	13.3	16.0	20.0	24.0
Working pressure	Rated MPa	31.5	31.5	31.5	31.5	25	25
	Max. MPa(10s duration)	35	35	35	35	30	30

Series		HG1				
Size		25	32	40	50	63
Weight	m kg	14.5	15	16	17	18.5
Speed	$n_{min}$ r/min	200	200	200	200	200
	$n_{max}$ r/min	3000	3000	3000	3000	3000
Displacement	V cm <sup>3</sup>	25.3	32.7	40.1	50.7	63.7
Working pressure	Rated MPa	31.5	31.5	31.5	31.5	25
	Max. MPa(10s duration)	35	35	35	35	30

Series		HG2						
Size		63	80	100	125	145	160	180
Weight	m kg	42	43.5	45.5	48	50	52	53.5
Speed	$n_{min}$ r/min	200	200	200	200	200	200	200
	$n_{max}$ r/min	3000	3000	3000	3000	3000	3000	3000
Displacement	V cm <sup>3</sup>	64.7	81.4	100.2	125.3	145.2	162.8	180.5
Working pressure	Rated MPa	31.5	31.5	31.5	31.5	25	21	19
	Max. MPa(10s duration)	35	35	35	35	28	26	23

➤ HG | Internal Gear Pump

Flow and pressure features (test conditions:  $n=1450\text{r/min}$ ,  $V=46\text{mm}^3/\text{s}$ ,  $t=50^\circ\text{C}$ )

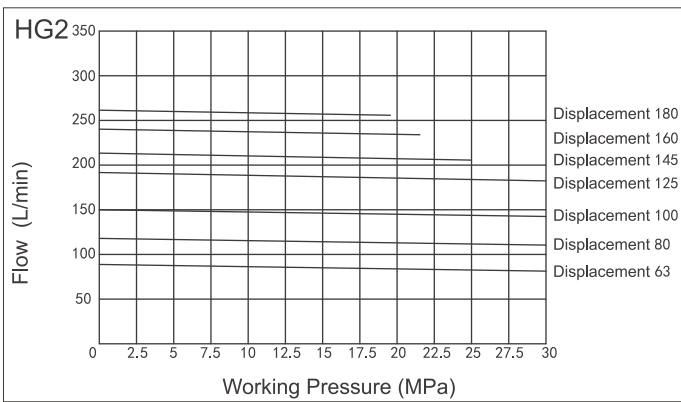
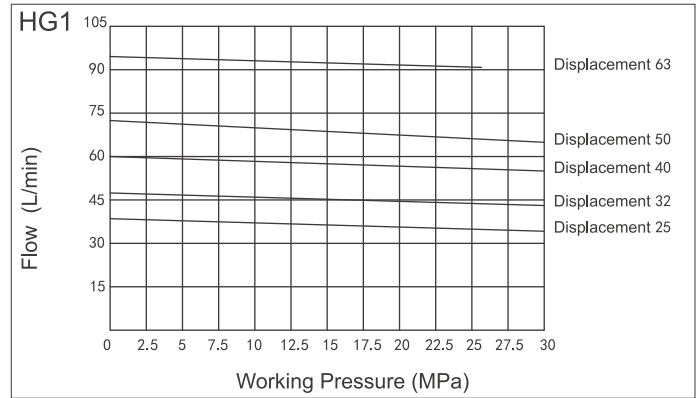
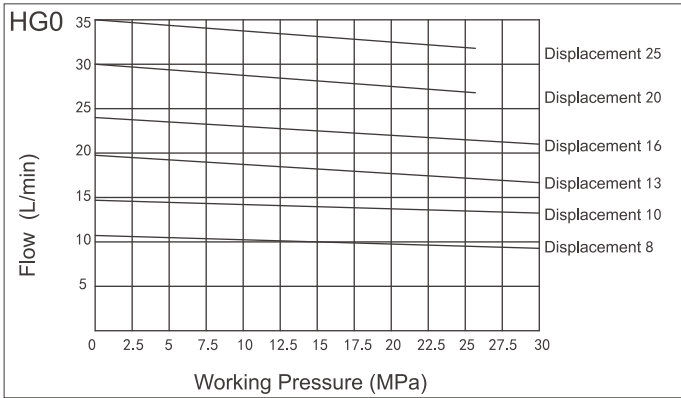

Noise and pressure features (test conditions:  $n=1450\text{r/min}$ ,  $V=46\text{mm}^3/\text{s}$ ,  $t=50^\circ\text{C}$ , distance from detector to pump=1 m)

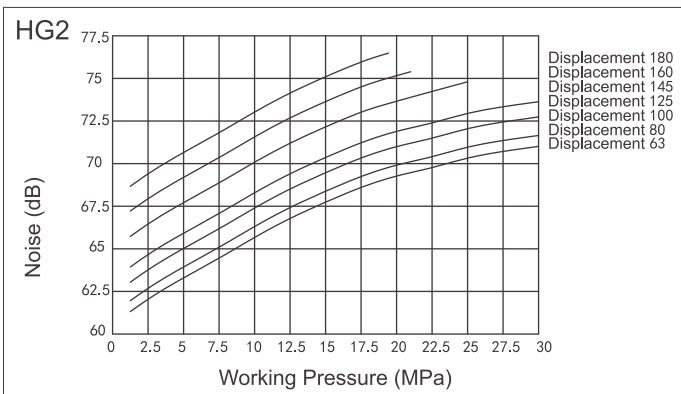
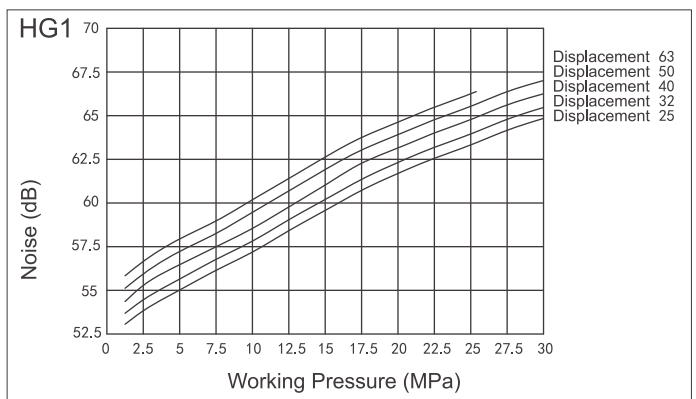
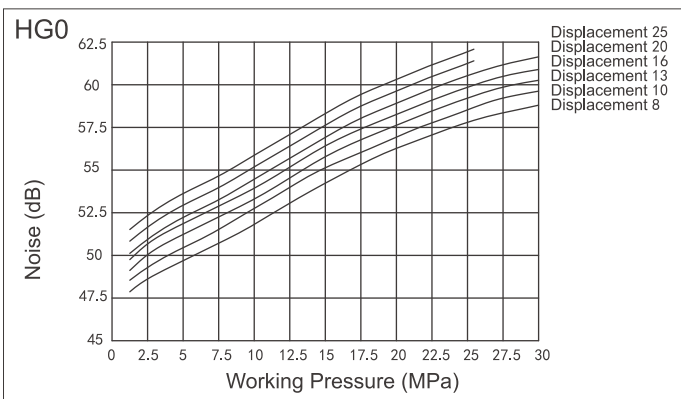

➤ **Installation Dimensions** (Unit:mm)

HG0-※-01R-VPC ((key shaft))

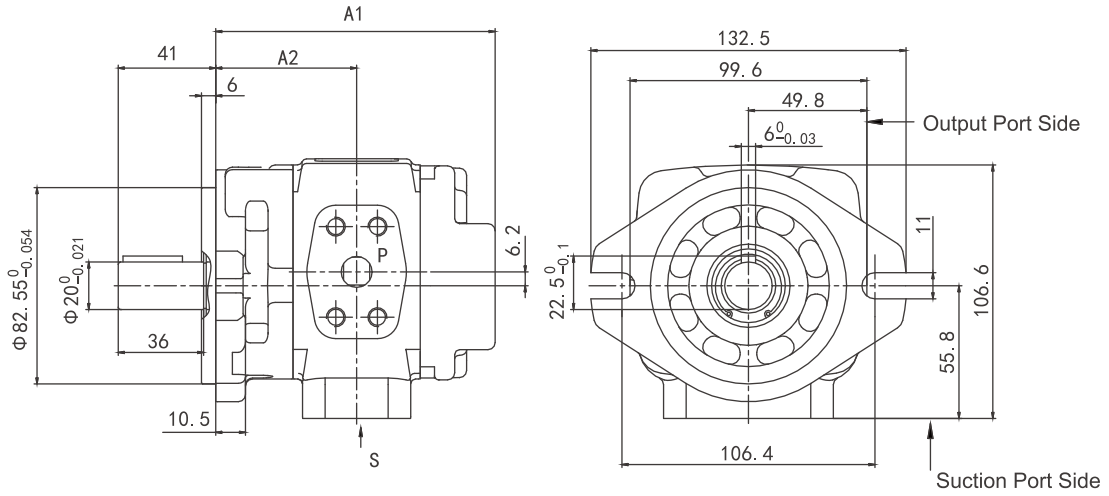

Model	A1	A2	S	P
HG0-08-01R-VPC	107	54	Φ 19	Φ 13
HG0-10-01R-VPC	111	56		
HG0-13-01R-VPC	117.5	59.25		
HG0-16-01R-VPC	123	62	Φ 26	Φ 18
HG0-20-01R-VPC	131	66		
HG0-25-01R-VPC	139	70	Φ 28	Φ 19

HG0-※-01R-VSC (spline shaft)

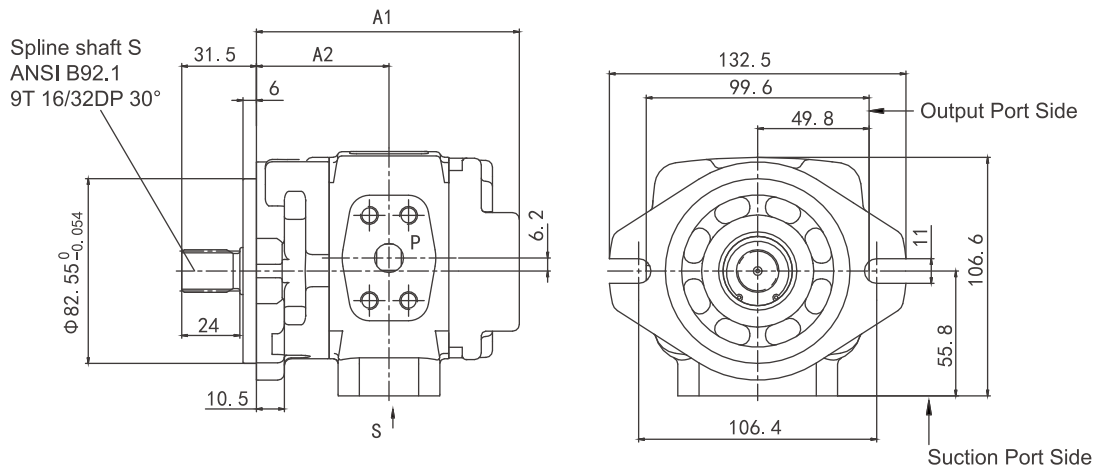

Model	A1	A2	S	P
HG0-08-01R-VSC	107	54	Φ 19	Φ 13
HG0-10-01R-VSC	111	56		
HG0-13-01R-VSC	117.5	59.25		
HG0-16-01R-VSC	123	62	Φ 26	Φ 18
HG0-20-01R-VSC	131	66		
HG0-25-01R-VSC	139	70	Φ 28	Φ 19

► Installation Dimensions (Unit:mm)

HG1-※-01R-VPC (key shaft)

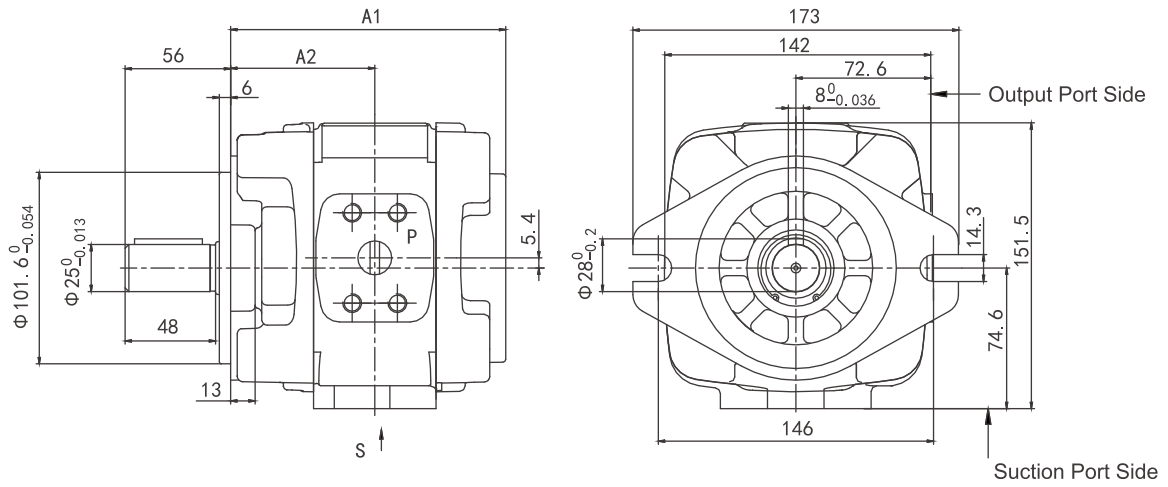

Model	A1	A2	S	P
HG1-25-01R-VPC-36	139	73	Φ 32	Φ 18
HG1-32-01R-VPC-36	146	76.5		
HG1-40-01R-VPC-36	153	80		Φ 20
HG1-50-01R-VPC-36	163	85		
HG1-63-01R-VPC-36	177	92		

HG1-※-01R-VSC (spline shaft)

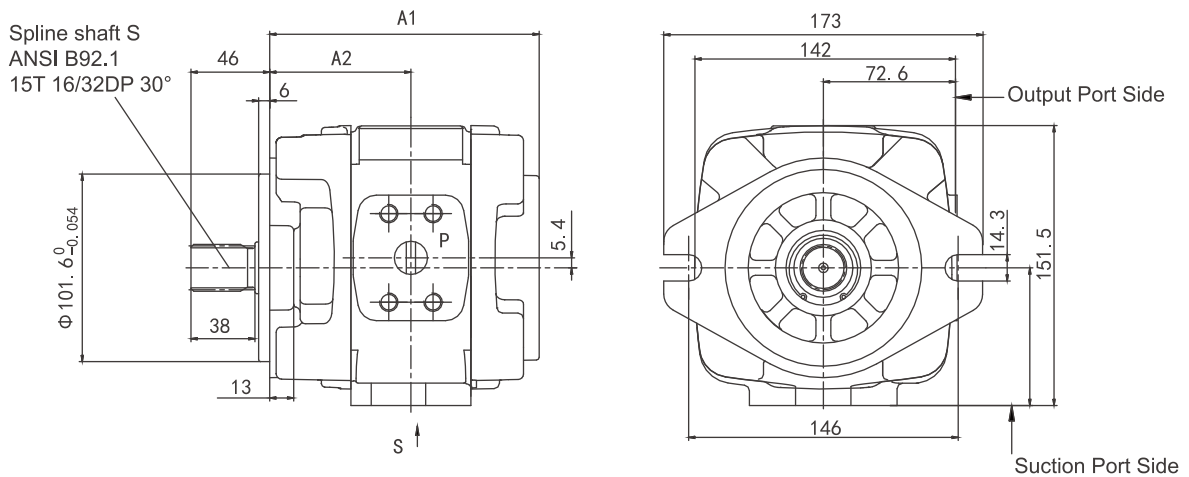

Model	A1	A2	S	P
HG1-25-01R-VSC-36	139	73	Φ 32	Φ 18
HG1-32-01R-VSC-36	146	76.5		
HG1-40-01R-VSC-36	153	80		Φ 20
HG1-50-01R-VSC-36	163	85		
HG1-63-01R-VSC-36	177	92		

➤ **Installation Dimensions** (Unit:mm)

HG2-※-01R-VPC (key shaft)

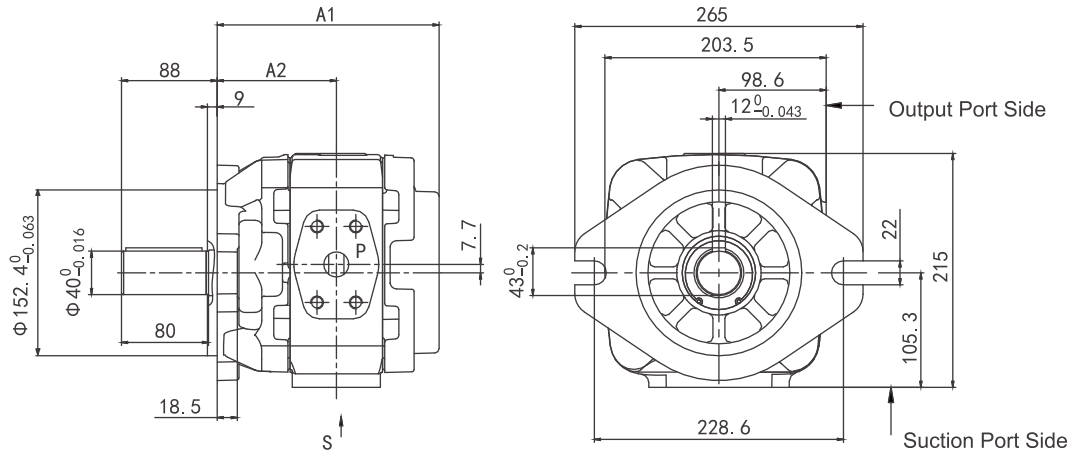

Model	A1	A2	S	P
HG2-63-01R-VPC-36	196	105.5	Φ 40	Φ 23
HG2-80-01R-VPC-36	204	109.5	Φ 51	Φ 32
HG2-100-01R-VPC-36	213	114		
HG2-125-01R-VPC-36	225	120	Φ 63.5	Φ 38
HG2-145-01R-VPC-36	235.5	124.75		
HG2-160-01R-VPC-36	243	129	Φ 76	
HG2-180-01R-VPC-36	251.5	133.25		

HG2-※-01R-VSC (spline shaft)

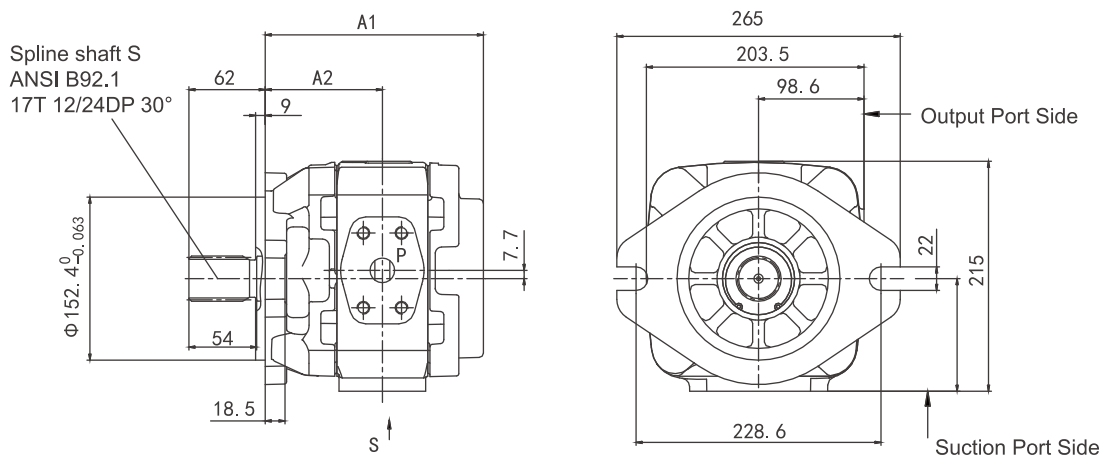

Model	A1	A2	S	P
HG2-63-01R-VSC-36	196	105.5	Φ 40	Φ 23
HG2-80-01R-VSC-36	204	109.5	Φ 51	Φ 32
HG2-100-01R-VSC-36	213	114		
HG2-125-01R-VSC-36	225	120	Φ 63.5	Φ 38
HG2-145-01R-VSC-36	235.5	124.75		
HG2-160-01R-VSC-36	243	129	Φ 76	
HG2-180-01R-VSC-36	251.5	133.25		



➤ Port Flange Dimensions (Unit:mm)

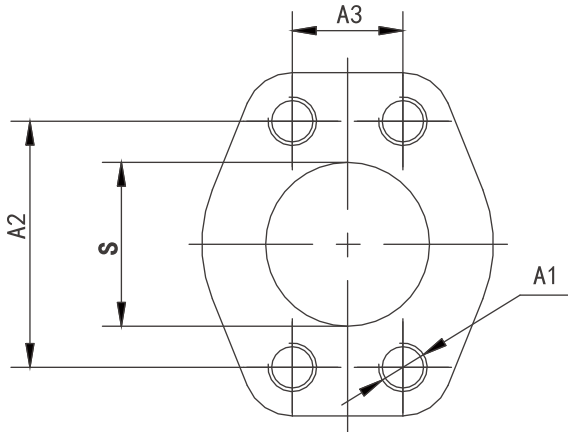

Suction Port "S"

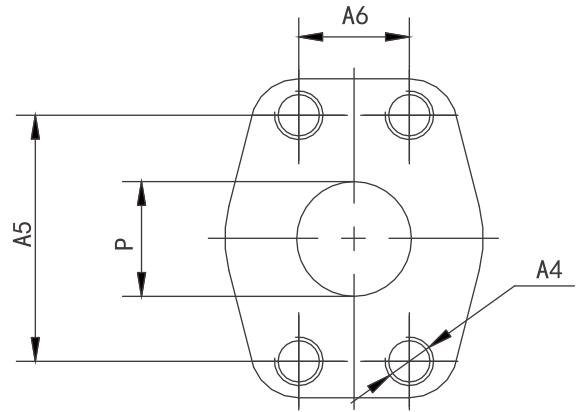

Output Port "P"

Series	Size	S	A1	A2	A3	P	A4	A5	A6
HG0	8	Φ 19	M10, 15 deep	47.6	22.2	Φ 13	M8, 13 deep	38.1	17.5
	10			52.4	26.2				
	13								
	16								
	20	Φ 26		58.7	30.2	Φ 18	M10, 15 deep	47.6	22.2
	25	Φ 28							
HG1	25	Φ 32	M10, 17 deep	58.7	30.2	Φ 18	M10, 17 deep	47.6	22.2
	32								
	40					Φ 20		52.4	26.2
	50								
	63								
HG2	63	Φ 40	M12, 20 deep	69.9	35.7	Φ 23	M10, 17 deep	52.4	26.2
	80	Φ 51		77.8	42.9	Φ 32	M12, 20 deep	69.9	35.7
	100								
	125	Φ 63.5		88.9	50.8	Φ 38	M16, 25 deep	79.4	36.5
	145								
	160	Φ 76		106.4	61.9				
	180								

## > HG Series Double Pump

### HG00/HG10/HG11/HG21/HG22 Series

A double pump is a combination of two single pumps which are connected in series and have one shared input port and two output ports connecting two separate loops. The combination of different pump series can realize different displacements.



## > Model Description

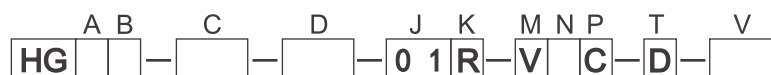

### Pump type

—	Internal gear pump	HG
---	--------------------	----

### Series

A	Front	Size:8. . . 25	0
		Size:25. . . 63	1
		Size:63. . . 160	2
B	Rear	Size:8. . . 25	0
		Size:25. . . 63	1
		Size:63. . . 160	2

### Displacement

C	Front	Series 0,Geometric displacement,ml/r	08	10	13	16	20	25
		Series 1,Geometric displacement,ml/r		25	32	40	50	63
		Series 2,Geometric displacement,ml/r	63	80	100	125	145	160
D	Rear	Series 0,Geometric displacement,ml/r	08	10	13	16	20	25
		Series 1,Geometric displacement,ml/r		25	32	40	50	63
		Series 2,Geometric displacement,ml/r	63	80	100	125	145	160

### Design code

J		01
---	--	----

### Input rotation direction

K	Clockwise (CW)	R
---	----------------	---

### Seal

M	Fluororubber	V
---	--------------	---

➤ Model Description

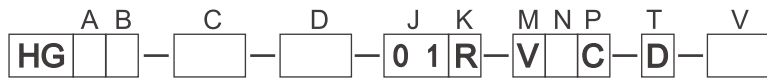

Shaft

		HG00	HG10	HG11	HG21	HG22	
N	Key shaft	●	●	●	●	●	P
	Spline shaft	●	●	●	●	●	S

Mounting flange

P	SAE 2 holes	C
---	-------------	---

Intermediate body

T	Newly designed intermediate body	D
---	----------------------------------	---

Special configuration

		HG00	HG10	HG11	HG21	HG22	
V		●	—	—	—	—	
	Reinforced locating pin	—	●	●	●	●	36

Remarks

● Available — Not applicable ■ Recommended model

➤ **Installation Dimensions** (Unit:mm)

HG00-※-※-01R-VPC (P shaft)

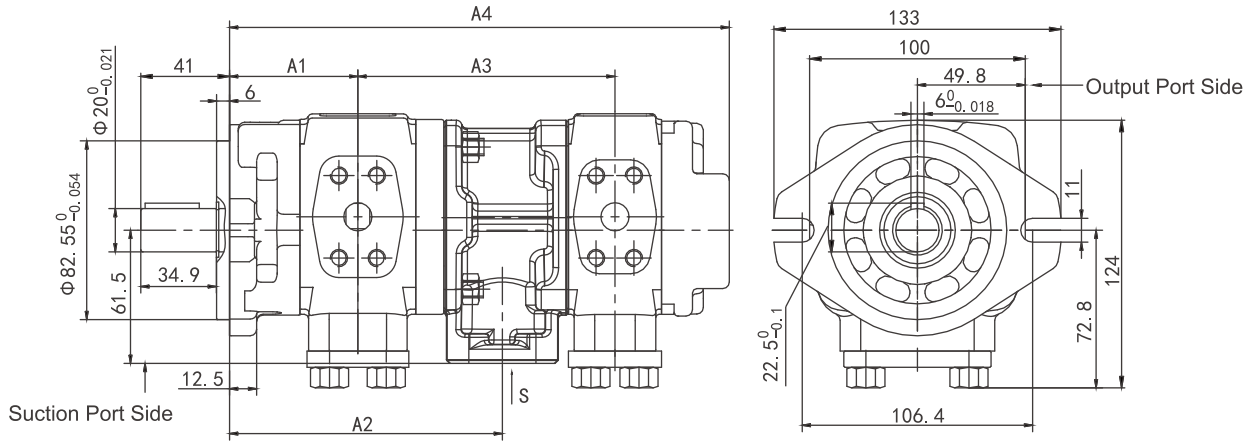

Model	A1	A2	Rear Pump Size										
			08		10		13		16		20		
			A3	A4	A3	A4	A3	A4	A3	A4	A3	A4	
HG00-08-※-01R-VPC	54	115.5	113.5	220.3									
HG00-10-※-01R-VPC	56	119.5	115.5	224.3	117.5	228.3							
HG00-13-※-01R-VPC	59.25	126	118.75	230.8	120.75	234.8	124	241.3					
HG00-16-※-01R-VPC	62	131.5	121.5	236.3	123.5	240.3	126.75	246.8	129.5	252.3			
HG00-20-※-01R-VPC	66	139.5	125.5	244.3	127.5	248.3	130.75	254.8	133.5	260.3	137.5	268.3	

HG00-※-※-01R-VSC (S shaft)

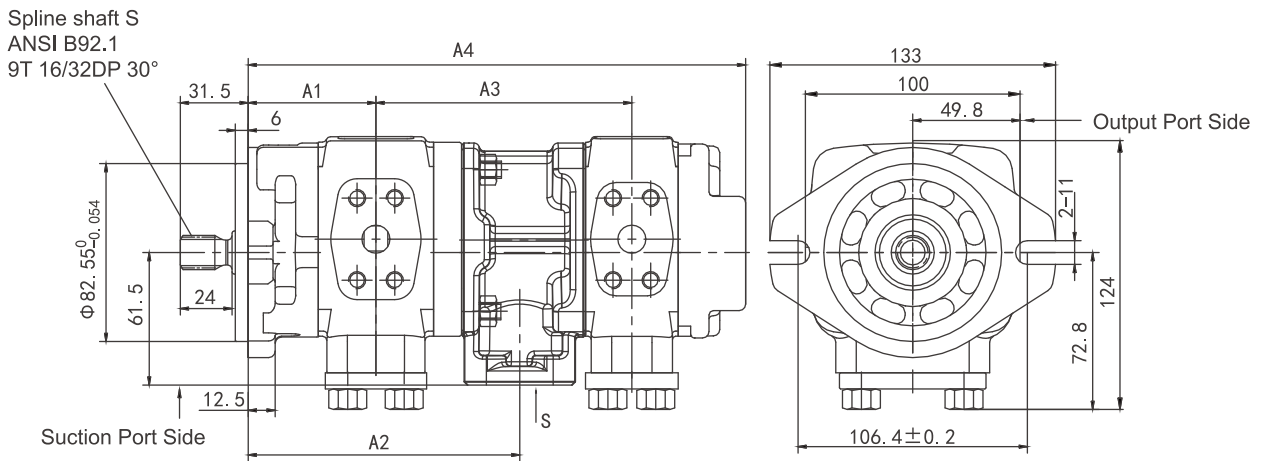

Model	A1	A2	Rear Pump Size										
			08		10		13		16		20		
			A3	A4	A3	A4	A3	A4	A3	A4	A3	A4	
HG00-08-※-01R-VSC	54	115.5	113.5	220.3									
HG00-10-※-01R-VSC	56	119.5	115.5	224.3	117.5	228.3							
HG00-13-※-01R-VSC	59.25	126	118.75	230.8	120.75	234.8	124	241.3					
HG00-16-※-01R-VSC	62	131.5	121.5	236.3	123.5	240.3	126.75	246.8	129.5	252.3			
HG00-20-※-01R-VSC	66	139.5	125.5	244.3	127.5	248.3	130.75	254.8	133.5	260.3	137.5	268.3	

► Installation Dimensions (Unit:mm)

HG10-※-※-01R-VPC-D (P shaft)

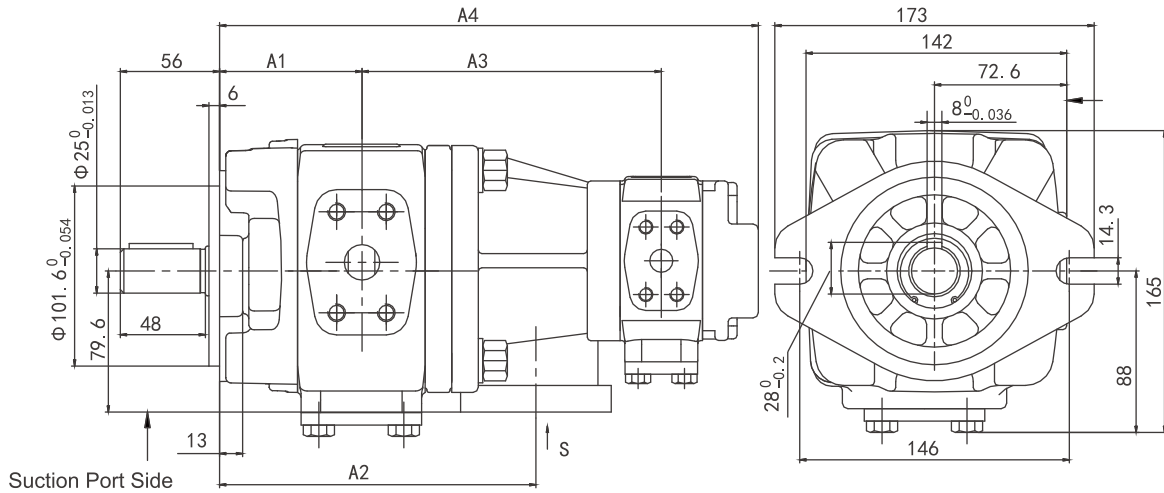

Model	A1	A2	Rear Pump Size											
			08		10		13		16		20		25	
			A3	A4	A3	A4	A3	A4	A3	A4	A3	A4	A3	A4
HG10-25-※-01R-VPC-D-36	73	153.5	138.5	264.5	140.5	268.5	143.8	275	146.5	280.5	150.5	288.5	154.5	296.5
HG10-32-※-01R-VPC-D-36	76.5	160.5	142	271.5	144	275.5	147.3	282	150	287.5	154	295.5	158	303.5
HG10-40-※-01R-VPC-D-36	80	167.5	145.5	278.5	147.5	282.5	150.8	289	153.5	294.5	157.5	302.5	161.5	310.5
HG10-50-※-01R-VPC-D-36	85	177.5	150.5	288.5	152.5	292.5	155.8	299	158.5	304.5	162.5	312.5	166.5	320.5
HG10-63-※-01R-VPC-D-36	92	191.5	157.5	302.5	159.5	306.5	162.8	313	165.5	318.5	169.5	326.5	173.5	334.5

HG10-※-※-01R-VSC-D (S shaft)

Spline shaft S  
ANSI B92.1  
15T 16/32DP 30°

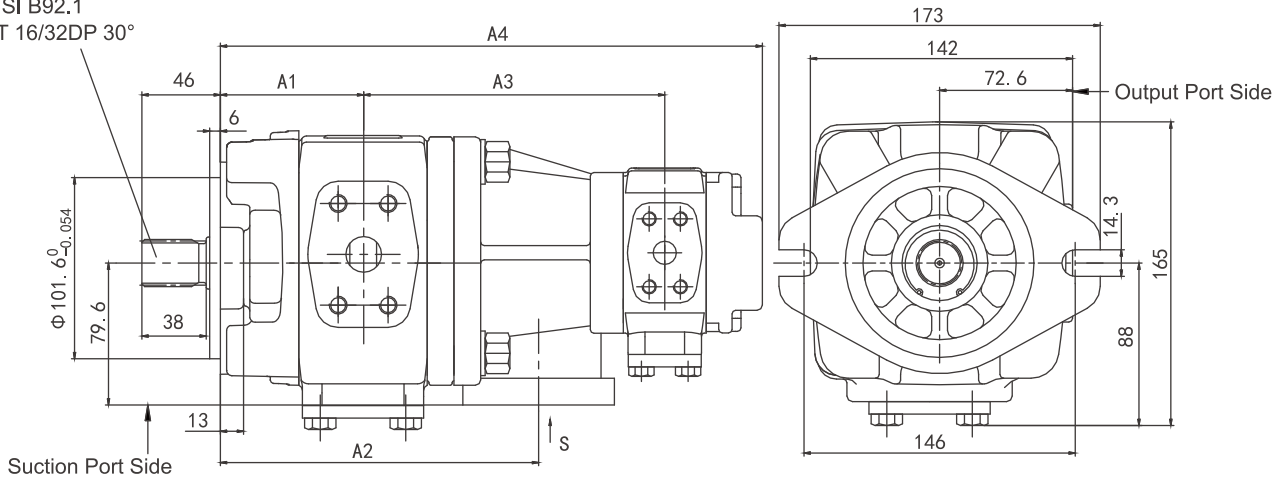

Model	A1	A2	Rear Pump Size											
			08		10		13		16		20		25	
			A3	A4	A3	A4	A3	A4	A3	A4	A3	A4	A3	A4
HG10-25-※-01R-VSC-D-36	73	153.5	138.5	264.5	140.5	268.5	143.8	275	146.5	280.5	150.5	288.5	154.5	296.5
HG10-32-※-01R-VSC-D-36	76.5	160.5	142	271.5	144	275.5	147.3	282	150	287.5	154	295.5	158	303.5
HG10-40-※-01R-VSC-D-36	80	167.5	145.5	278.5	147.5	282.5	150.8	289	153.5	294.5	157.5	302.5	161.5	310.5
HG10-50-※-01R-VSC-D-36	85	177.5	150.5	288.5	152.5	292.5	155.8	299	158.5	304.5	162.5	312.5	166.5	320.5
HG10-63-※-01R-VSC-D-36	92	191.5	157.5	302.5	159.5	306.5	162.8	313	165.5	318.5	169.5	326.5	173.5	334.5

➤ **Installation Dimensions** (Unit:mm)

HG11-※-※-01R-VPC-D (P shaft)

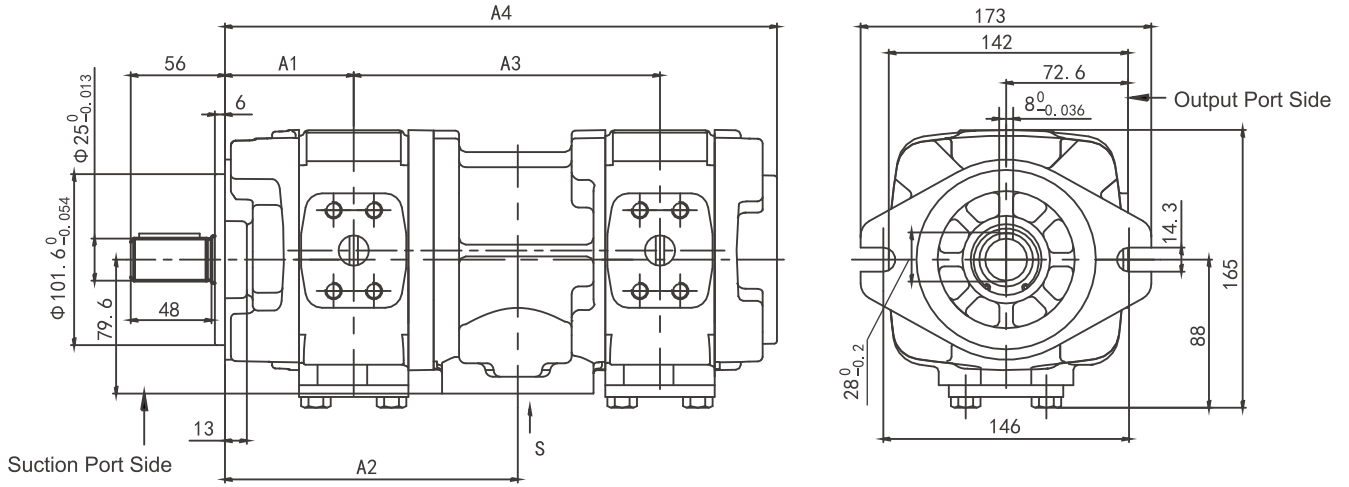

Model	A1	A2	Rear Pump Size											
			25		32		40		50		63			
			A3	A4	A3	A4	A3	A4	A3	A4	A3	A4		
HG11-25-※-01R-VPC-D-36	73	161	161	300										
HG11-32-※-01R-VPC-D-36	76.5	168	164.5	307	168	314								
HG11-40-※-01R-VPC-D-36	80	175	168	314	171.5	321	175	328						
HG11-50-※-01R-VPC-D-36	85	185	173	324	176.5	331	180	338	185	348				
HG11-63-※-01R-VPC-D-36	92	199	180	338	183.5	345	187	352	192	362	199	376		

HG11-※-※-01R-VSC-D (S shaft)

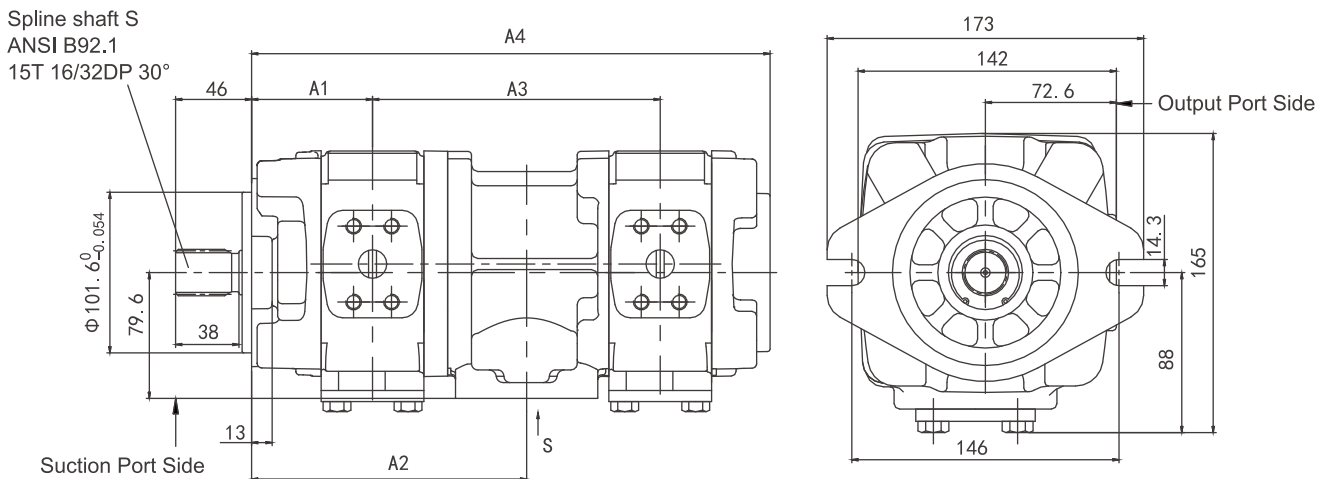

Model	A1	A2	Rear Pump Size											
			25		32		40		50		63			
			A3	A4	A3	A4	A3	A4	A3	A4	A3	A4		
HG11-25-※-01R-VSC-D-36	73	161	161	300										
HG11-32-※-01R-VSC-D-36	76.5	168	164.5	307	168	314								
HG11-40-※-01R-VSC-D-36	80	175	168	314	171.5	321	175	328						
HG11-50-※-01R-VSC-D-36	85	185	173	324	176.5	331	180	338	185	348				
HG11-63-※-01R-VSC-D-36	92	199	180	338	183.5	345	187	352	192	362	199	376		

➤ Installation Dimensions (Unit:mm)

HG21-※-※-01R-VPC-D (P shaft)

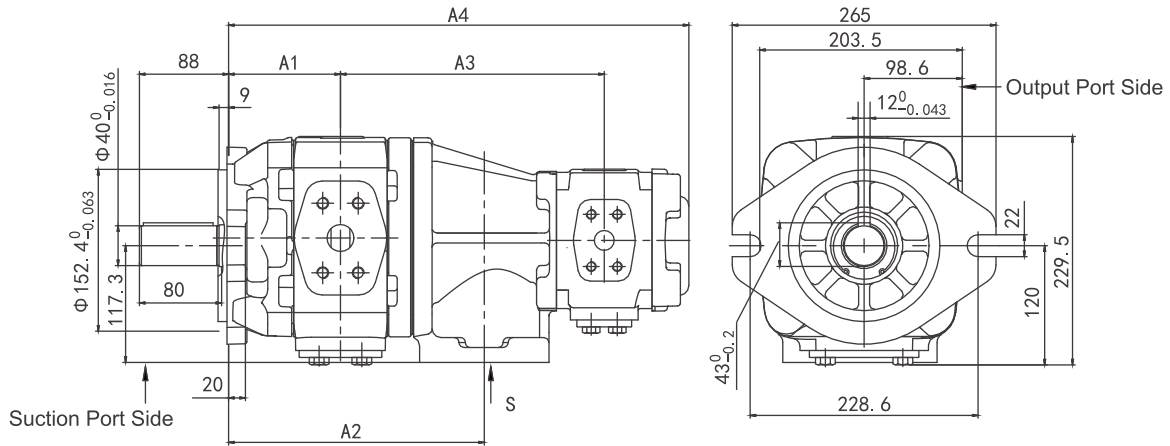

Model	A1	A2	Rear Pump Size									
			25		32		40		50		63	
			A3	A4	A3	A4	A3	A4	A3	A4	A3	A4
HG21-63-※-01R-VPC-D-36	105.5	223	200.5	372	204	379	207.5	386	212.5	396	219.5	410
HG21-80-※-01R-VPC-D-36	109.5	231	204.5	380	208	387	211.5	394	216.5	404	223.5	418
HG21-100-※-01R-VPC-D-36	114	240	209	389	212.5	396	216	403	221	413	228	427
HG21-125-※-01R-VPC-D-36	120	252	215	401	218.5	408	222	415	227	425	234	439
HG21-145-※-01R-VPC-D-36	124.8	261.5	219.8	410.5	223.3	417.5	226.8	424.5	231.8	434.5	238.8	448.5
HG21-160-※-01R-VPC-D-36	129	270	224	419	227.5	426	231	433	236	443	243	457

HG21-※-※-01R-VSC-D (S shaft)

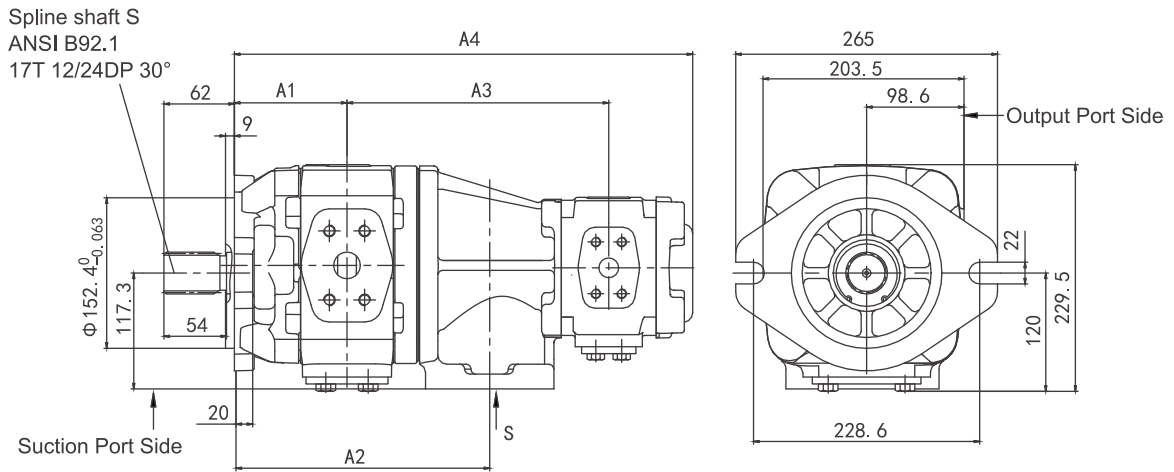

Model	A1	A2	Rear Pump Size									
			25		32		40		50		63	
			A3	A4	A3	A4	A3	A4	A3	A4	A3	A4
HG21-63-※-01R-VPC-D-36	105.5	223	200.5	372	204	379	207.5	386	212.5	396	219.5	410
HG21-80-※-01R-VPC-D-36	109.5	231	204.5	380	208	387	211.5	394	216.5	404	223.5	418
HG21-100-※-01R-VPC-D-36	114	240	209	389	212.5	396	216	403	221	413	228	427
HG21-125-※-01R-VPC-D-36	120	252	215	401	218.5	408	222	415	227	425	234	439
HG21-145-※-01R-VPC-D-36	124.8	261.5	219.8	410.5	223.3	417.5	226.8	424.5	231.8	434.5	238.8	448.5
HG21-160-※-01R-VPC-D-36	129	270	224	419	227.5	426	231	433	236	443	243	457

► **Installation Dimensions** (Unit:mm)

HG22-※-※-01R-VPC-D (P shaft)

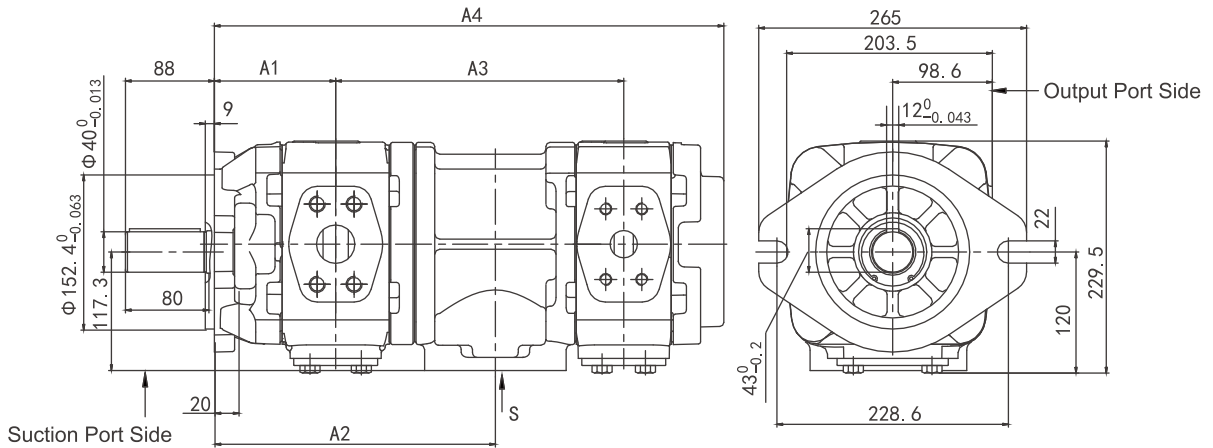

Model	A1	A2	Rear Pump Size													
			63		80		100		125		145		160			
			A3	A4	A3	A4	A3	A4	A3	A4	A3	A4	A3	A4		
HG22-63-※-01R-VPC-D-36	105.5	230.5	225	421												
HG22-80-※-01R-VPC-D-36	109.5	238.5	229	429	233	437										
HG22-100-※-01R-VPC-D-36	114	247.5	233.5	438	237.5	446	242	455								
HG22-125-※-01R-VPC-D-36	120	259.5	239.5	450	243.5	458	248	467	254	479						
HG22-145-※-01R-VPC-D-36	124.5	269	244.3	459.5	248.3	467.5	252.8	476.5	258.8	488.5	263.5	498				
HG22-160-※-01R-VPC-D-36	129	277.5	248.5	468	251.5	476	257	485	263	497	268.3	506.5	272	515		

HG22-※-※-01R-VSC-D (S shaft)

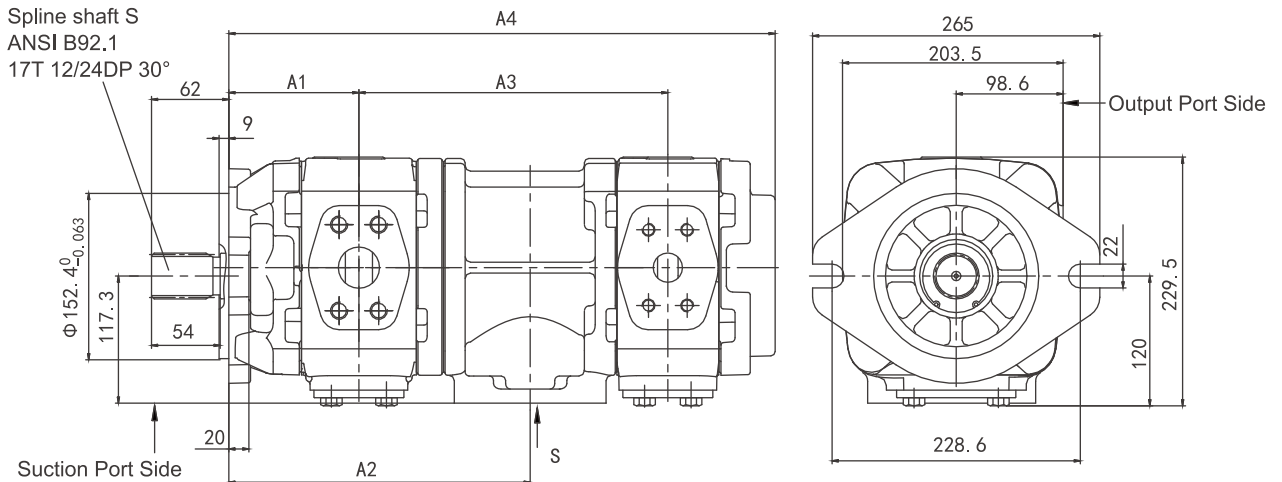

Model	A1	A2	Rear Pump Size													
			63		80		100		125		145		160			
			A3	A4	A3	A4	A3	A4	A3	A4	A3	A4	A3	A4		
HG22-63-※-01R-VSC-D-36	105.5	230.5	225	421												
HG22-80-※-01R-VSC-D-36	109.5	238.5	229	429	233	437										
HG22-100-※-01R-VSC-D-36	114	247.5	233.5	438	237.5	446	242	455								
HG22-125-※-01R-VSC-D-36	120	259.5	239.5	450	243.5	458	248	467	254	479						
HG22-145-※-01R-VSC-D-36	124.5	269	244.3	459.5	248.3	467.5	252.8	476.5	258.8	488.5	263.5	498				
HG22-160-※-01R-VSC-D-36	129	277.5	248.5	468	251.5	476	257	485	263	497	268.3	506.5	272	515		



➤ Port Flange Dimensions (Unit:mm)

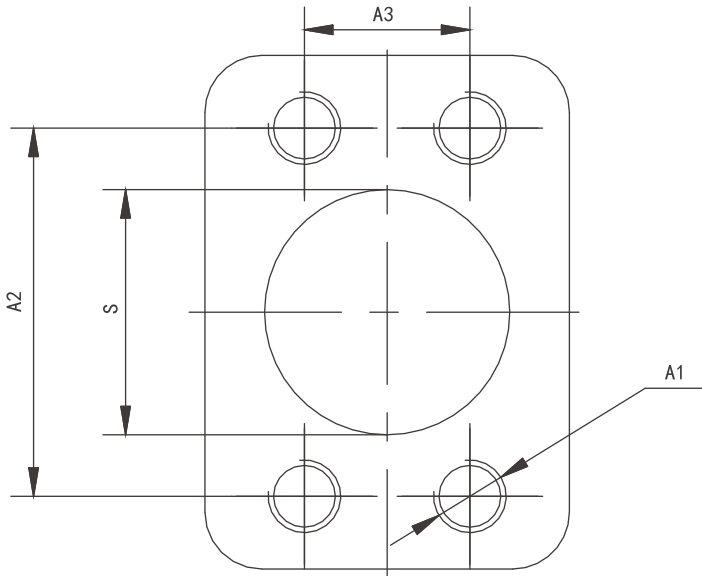

Double Pump Suction Port "S"

Series	S	A1	A2	A3
HG00	Φ 32	M10, 17 deep	58.7	30.2
HG10	Φ 38	M12, 20 deep	69.9	35.7
HG11	Φ 51		77.8	42.9
HG21	Φ 76	M16, 25 deep	106.4	61.9
HG22	Φ 89		120.7	69.9

## > Precautions for Use

### 1. Drive Mechanism

Motor + Bell guard + Coupling + Pump

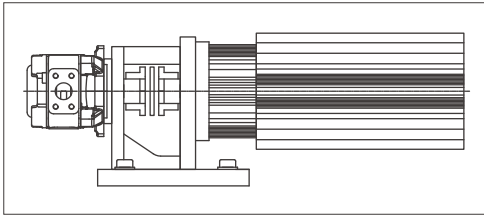

- The pump is not allowed to apply axial and radial forces on the drive shaft!
- The axes of the motor and the pump must be properly aligned!
- Always use a coupling that can realize compensation for shaft misalignment!
- Avoid axial force and the use of knocking tools when installing the coupling!
- Gently knock on the soft pad based on the fit tolerance of coupling!

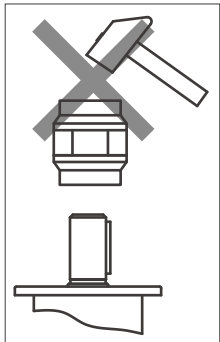

### 2. Installation

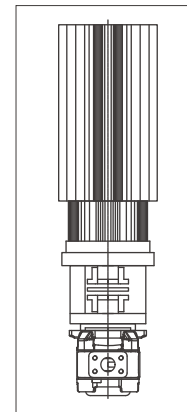
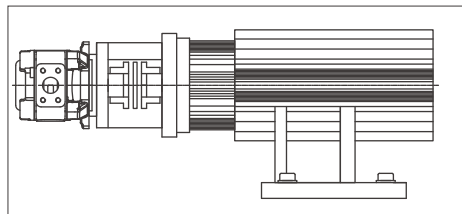
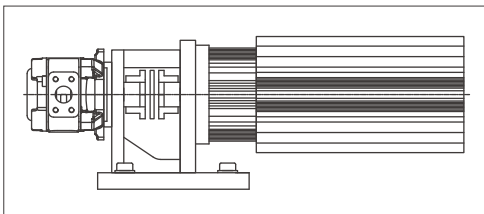

### 3. Preparations

- Check whether the equipment is installed in a careful and clean manner.
- Use only the filter with the required minimum filter rating for oil filling.
- Fill the pump with oil through the suction line or pressure line.
- Check consistency of motor direction with pump direction based on the pump model.

### 4. Air Bleeding

- Manually open the air vent on the equipment or turn on zero-pressure circulation according to user manual of the equipment. Make sure the trapped air is discharged under no pressure in the venting process.
- Shortly start and promptly stop (inching) the motor to discharge air in the pump. Repeat this process until air in the pump is completely discharged.
- Close the manually opened air vent.

**➤ Precautions for Use**

**5. Put to Use**

- Start the motor after confirming air in the pump is completely discharged.
- Run the pump under no pressure until air in the equipment is thoroughly discharged. Please observe the equipment user manual for venting.
- Put the equipment in use and load the pump according to the equipment user manual.
- Check liquid in the oil tank for bubbles or foam on the surface after operation for a certain period of time.

**6. Operation**

- Pay attention to change in noise during operation. Minor increase of noise is normal due to temperature rise of the working medium. Significant noise increase or temporary severe noise fluctuations may be the symptom of intake of air.
- Air may be sucked with whirlpool caused by short suction pipe or low filling height of working medium.
- Speed change, temperature change, intensified noise and change in power consumption all indicate wear or damage of the equipment or pump.

**7. Operation after Servicing**

- Check air tightness of the pump and the equipment. Leakage indicates poor tightness below the liquid.
- Rise in liquid level of the oil tank indicates poor tightness above the liquid.
- The pump may idle due to poor tightness incurred by worn shaft seal or other factors when the pump is installed above the pressure liquid.
- In this case, air discharge is required for repair before it is put in use again.
- Make sure to discharge the air after repair and maintenance.
- Start the motor on condition that the equipment is in good condition.

**⚠ Important Tips**

- Only authorized, properly educated and trained personnel are allowed to carry out pump installation and maintenance!
- Use only allowable data for running the pump!
- Use only the pump in good condition!
- Make sure to turn the equipment to zero pressure mode before any work on the pump!
- Do not remove existing safety devices when installing additional ones (such as coupling protection)!
- Always check whether all fixing bolts are properly fastened (note the specified tightening torque)!
- Make sure to observe the universal and valid safety and accident prevention regulations!

**! Recommended fit tolerance for coupling hole: H7**  
 (to be made by experienced manufacturer to standard tolerance for minor interference fit)

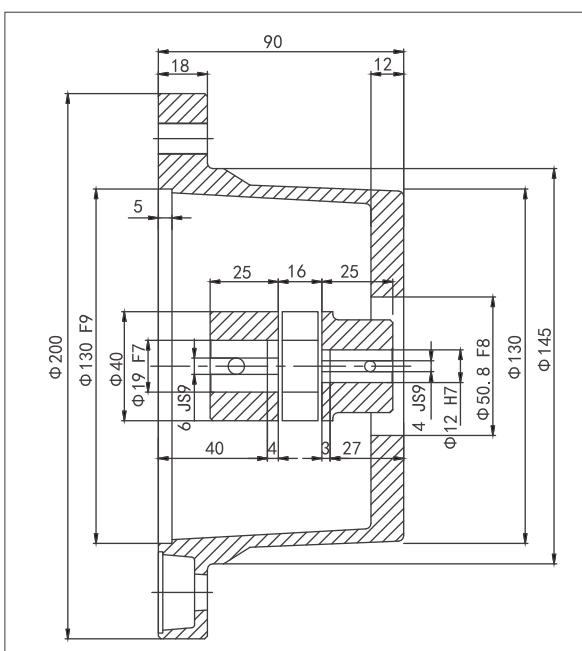

**Hytek Power Co., Ltd.**

No.156, West Yuele Street, Lucheng District,  
Wenzhou, Zhejiang, CHINA

+86-577-89615902

[globalsales@hytek.cn](mailto:globalsales@hytek.cn)

[www.hytek.cn/en](http://www.hytek.cn/en)